

INVERTEC V350-PRO

For use with machine code numbers **10873, 10874, 10876**

Safety Depends on You

Lincoln arc welding and cutting equipment is designed and built with safety in mind. However, your overall safety can be increased by proper installation . . . and thoughtful operation on your part. **DO NOT INSTALL, OPERATE OR REPAIR THIS EQUIPMENT WITHOUT READING THIS MANUAL AND THE SAFETY PRECAUTIONS CONTAINED THROUGHOUT.** And, most importantly, think before you act and be careful.

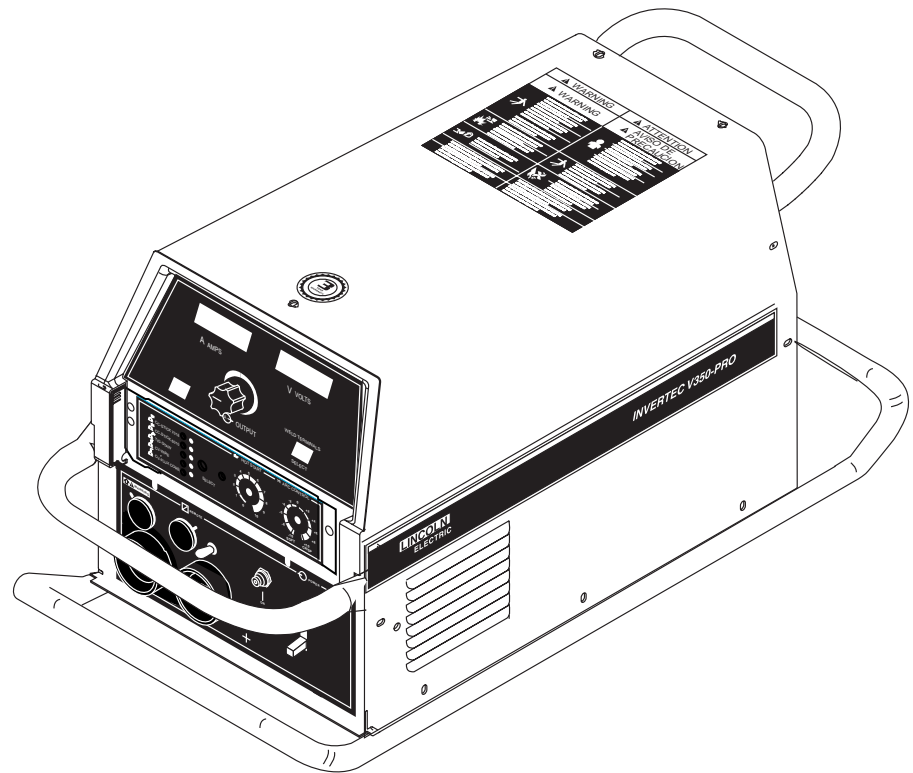

SERVICE MANUAL

LINCOLN[®]
ELECTRIC

Copyright © 2002 Lincoln Global Inc.

• World's Leader in Welding and Cutting Products •

• Sales and Service through Subsidiaries and Distributors Worldwide •

Cleveland, Ohio 44117-1199 U.S.A. TEL: 216.481.8100 FAX: 216.486.1751 WEB SITE: www.lincolnelectric.com

⚠ WARNING

⚠ CALIFORNIA PROPOSITION 65 WARNINGS ⚠

Diesel engine exhaust and some of its constituents are known to the State of California to cause cancer, birth defects, and other reproductive harm.

The Above For Diesel Engines

The engine exhaust from this product contains chemicals known to the State of California to cause cancer, birth defects, or other reproductive harm.

The Above For Gasoline Engines

ARC WELDING CAN BE HAZARDOUS. PROTECT YOURSELF AND OTHERS FROM POSSIBLE SERIOUS INJURY OR DEATH. KEEP CHILDREN AWAY. PACEMAKER WEARERS SHOULD CONSULT WITH THEIR DOCTOR BEFORE OPERATING.

Read and understand the following safety highlights. For additional safety information, it is strongly recommended that you purchase a copy of "Safety in Welding & Cutting - ANSI Standard Z49.1" from the American Welding Society, P.O. Box 351040, Miami, Florida 33135 or CSA Standard W117.2-1974. A Free copy of "Arc Welding Safety" booklet E205 is available from the Lincoln Electric Company, 22801 St. Clair Avenue, Cleveland, Ohio 44117-1199.

BE SURE THAT ALL INSTALLATION, OPERATION, MAINTENANCE AND REPAIR PROCEDURES ARE PERFORMED ONLY BY QUALIFIED INDIVIDUALS.



FOR ENGINE powered equipment.

1.a. Turn the engine off before troubleshooting and maintenance work unless the maintenance work requires it to be running.



1.b. Operate engines in open, well-ventilated areas or vent the engine exhaust fumes outdoors.



1.c. Do not add the fuel near an open flame welding arc or when the engine is running. Stop the engine and allow it to cool before refueling to prevent spilled fuel from vaporizing on contact with hot engine parts and igniting. Do not spill fuel when filling tank. If fuel is spilled, wipe it up and do not start engine until fumes have been eliminated.

1.d. Keep all equipment safety guards, covers and devices in position and in good repair. Keep hands, hair, clothing and tools away from V-belts, gears, fans and all other moving parts when starting, operating or repairing equipment.

1.e. In some cases it may be necessary to remove safety guards to perform required maintenance. Remove guards only when necessary and replace them when the maintenance requiring their removal is complete. Always use the greatest care when working near moving parts.



1.f. Do not put your hands near the engine fan. Do not attempt to override the governor or idler by pushing on the throttle control rods while the engine is running.

1.g. To prevent accidentally starting gasoline engines while turning the engine or welding generator during maintenance work, disconnect the spark plug wires, distributor cap or magneto wire as appropriate.



1.h. To avoid scalding, do not remove the radiator pressure cap when the engine is hot.



ELECTRIC AND MAGNETIC FIELDS may be dangerous

- 2.a. Electric current flowing through any conductor causes localized Electric and Magnetic Fields (EMF). Welding current creates EMF fields around welding cables and welding machines
- 2.b. EMF fields may interfere with some pacemakers, and welders having a pacemaker should consult their physician before welding.
- 2.c. Exposure to EMF fields in welding may have other health effects which are now not known.
- 2.d. All welders should use the following procedures in order to minimize exposure to EMF fields from the welding circuit:
 - 2.d.1. Route the electrode and work cables together - Secure them with tape when possible.
 - 2.d.2. Never coil the electrode lead around your body.
 - 2.d.3. Do not place your body between the electrode and work cables. If the electrode cable is on your right side, the work cable should also be on your right side.
 - 2.d.4. Connect the work cable to the workpiece as close as possible to the area being welded.
 - 2.d.5. Do not work next to welding power source.

Mar '95



ELECTRIC SHOCK can kill.

- 3.a. The electrode and work (or ground) circuits are electrically "hot" when the welder is on. Do not touch these "hot" parts with your bare skin or wet clothing. Wear dry, hole-free gloves to insulate hands.
- 3.b. Insulate yourself from work and ground using dry insulation. Make certain the insulation is large enough to cover your full area of physical contact with work and ground.
- In addition to the normal safety precautions, if welding must be performed under electrically hazardous conditions (in damp locations or while wearing wet clothing; on metal structures such as floors, gratings or scaffolds; when in cramped positions such as sitting, kneeling or lying, if there is a high risk of unavoidable or accidental contact with the workpiece or ground) use the following equipment:**
- Semiautomatic DC Constant Voltage (Wire) Welder.
 - DC Manual (Stick) Welder.
 - AC Welder with Reduced Voltage Control.
- 3.c. In semiautomatic or automatic wire welding, the electrode, electrode reel, welding head, nozzle or semiautomatic welding gun are also electrically "hot".
- 3.d. Always be sure the work cable makes a good electrical connection with the metal being welded. The connection should be as close as possible to the area being welded.
- 3.e. Ground the work or metal to be welded to a good electrical (earth) ground.
- 3.f. Maintain the electrode holder, work clamp, welding cable and welding machine in good, safe operating condition. Replace damaged insulation.
- 3.g. Never dip the electrode in water for cooling.
- 3.h. Never simultaneously touch electrically "hot" parts of electrode holders connected to two welders because voltage between the two can be the total of the open circuit voltage of both welders.
- 3.i. When working above floor level, use a safety belt to protect yourself from a fall should you get a shock.
- 3.j. Also see Items 6.c. and 8.



ARC RAYS can burn.

- 4.a. Use a shield with the proper filter and cover plates to protect your eyes from sparks and the rays of the arc when welding or observing open arc welding. Headshield and filter lens should conform to ANSI Z87.1 standards.
- 4.b. Use suitable clothing made from durable flame-resistant material to protect your skin and that of your helpers from the arc rays.
- 4.c. Protect other nearby personnel with suitable, non-flammable screening and/or warn them not to watch the arc nor expose themselves to the arc rays or to hot spatter or metal.



FUMES AND GASES can be dangerous.

- 5.a. Welding may produce fumes and gases hazardous to health. Avoid breathing these fumes and gases. When welding, keep your head out of the fume. Use enough ventilation and/or exhaust at the arc to keep fumes and gases away from the breathing zone. **When welding with electrodes which require special ventilation such as stainless or hard facing (see instructions on container or MSDS) or on lead or cadmium plated steel and other metals or coatings which produce highly toxic fumes, keep exposure as low as possible and below Threshold Limit Values (TLV) using local exhaust or mechanical ventilation. In confined spaces or in some circumstances, outdoors, a respirator may be required. Additional precautions are also required when welding on galvanized steel.**
- 5.b. Do not weld in locations near chlorinated hydrocarbon vapors coming from degreasing, cleaning or spraying operations. The heat and rays of the arc can react with solvent vapors to form phosgene, a highly toxic gas, and other irritating products.
- 5.c. Shielding gases used for arc welding can displace air and cause injury or death. Always use enough ventilation, especially in confined areas, to insure breathing air is safe.
- 5.d. Read and understand the manufacturer's instructions for this equipment and the consumables to be used, including the material safety data sheet (MSDS) and follow your employer's safety practices. MSDS forms are available from your welding distributor or from the manufacturer.
- 5.e. Also see item 1.b.

Mar '95

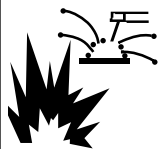

WELDING SPARKS can cause fire or explosion.

6.a. Remove fire hazards from the welding area. If this is not possible, cover them to prevent the welding sparks from starting a fire.

Remember that welding sparks and hot materials from welding can easily go through small cracks and openings to adjacent areas. Avoid welding near hydraulic lines. Have a fire extinguisher readily available.

6.b. Where compressed gases are to be used at the job site, special precautions should be used to prevent hazardous situations. Refer to "Safety in Welding and Cutting" (ANSI Standard Z49.1) and the operating information for the equipment being used.

6.c. When not welding, make certain no part of the electrode circuit is touching the work or ground. Accidental contact can cause overheating and create a fire hazard.

6.d. Do not heat, cut or weld tanks, drums or containers until the proper steps have been taken to insure that such procedures will not cause flammable or toxic vapors from substances inside. They can cause an explosion even though they have been "cleaned". For information, purchase "Recommended Safe Practices for the Preparation for Welding and Cutting of Containers and Piping That Have Held Hazardous Substances", AWS F4.1 from the American Welding Society (see address above).

6.e. Vent hollow castings or containers before heating, cutting or welding. They may explode.

6.f. Sparks and spatter are thrown from the welding arc. Wear oil free protective garments such as leather gloves, heavy shirt, cuffless trousers, high shoes and a cap over your hair. Wear ear plugs when welding out of position or in confined places. Always wear safety glasses with side shields when in a welding area.

6.g. Connect the work cable to the work as close to the welding area as practical. Work cables connected to the building framework or other locations away from the welding area increase the possibility of the welding current passing through lifting chains, crane cables or other alternate circuits. This can create fire hazards or overheat lifting chains or cables until they fail.

6.h. Also see item 1.c.

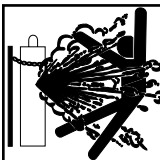

CYLINDER may explode if damaged.

7.a. Use only compressed gas cylinders containing the correct shielding gas for the process used and properly operating regulators designed for the gas and pressure used. All hoses, fittings, etc. should be suitable for the application and maintained in good condition.

7.b. Always keep cylinders in an upright position securely chained to an undercarriage or fixed support.

7.c. Cylinders should be located:

- Away from areas where they may be struck or subjected to physical damage.

- A safe distance from arc welding or cutting operations and any other source of heat, sparks, or flame.

7.d. Never allow the electrode, electrode holder or any other electrically "hot" parts to touch a cylinder.

7.e. Keep your head and face away from the cylinder valve outlet when opening the cylinder valve.

7.f. Valve protection caps should always be in place and hand tight except when the cylinder is in use or connected for use.

7.g. Read and follow the instructions on compressed gas cylinders, associated equipment, and CGA publication P-1, "Precautions for Safe Handling of Compressed Gases in Cylinders," available from the Compressed Gas Association 1235 Jefferson Davis Highway, Arlington, VA 22202.



FOR ELECTRICALLY powered equipment.

8.a. Turn off input power using the disconnect switch at the fuse box before working on the equipment.

8.b. Install equipment in accordance with the U.S. National Electrical Code, all local codes and the manufacturer's recommendations.

8.c. Ground the equipment in accordance with the U.S. National Electrical Code and the manufacturer's recommendations.

Mar '95

V350-PRO

LINCOLN[®]
ELECTRIC

PRÉCAUTIONS DE SÛRETÉ

Pour votre propre protection lire et observer toutes les instructions et les précautions de sûreté spécifiques qui paraissent dans ce manuel aussi bien que les précautions de sûreté générales suivantes:

Sûreté Pour Soudage A L'Arc

1. Protégez-vous contre la secousse électrique:
 - a. Les circuits à l'électrode et à la pièce sont sous tension quand la machine à souder est en marche. Éviter toujours tout contact entre les parties sous tension et la peau nue ou les vêtements mouillés. Porter des gants secs et sans trous pour isoler les mains.
 - b. Faire très attention de bien s'isoler de la masse quand on soude dans des endroits humides, ou sur un plancher métallique ou des grilles métalliques, principalement dans les positions assis ou couché pour lesquelles une grande partie du corps peut être en contact avec la masse.
 - c. Maintenir le porte-électrode, la pince de masse, le câble de soudage et la machine à souder en bon et sûr état de fonctionnement.
 - d. Ne jamais plonger le porte-électrode dans l'eau pour le refroidir.
 - e. Ne jamais toucher simultanément les parties sous tension des porte-électrodes connectés à deux machines à souder parce que la tension entre les deux pinces peut être le total de la tension à vide des deux machines.
 - f. Si on utilise la machine à souder comme une source de courant pour soudage semi-automatique, ces précautions pour le porte-électrode s'appliquent aussi au pistolet de soudage.
2. Dans le cas de travail au dessus du niveau du sol, se protéger contre les chutes dans le cas où on recoit un choc. Ne jamais enrouler le câble-électrode autour de n'importe quelle partie du corps.
3. Un coup d'arc peut être plus sévère qu'un coup de soleil, donc:
 - a. Utiliser un bon masque avec un verre filtrant approprié ainsi qu'un verre blanc afin de se protéger les yeux du rayonnement de l'arc et des projections quand on soude ou quand on regarde l'arc.
 - b. Porter des vêtements convenables afin de protéger la peau de soudeur et des aides contre le rayonnement de l'arc.
 - c. Protéger l'autre personnel travaillant à proximité au soudage à l'aide d'écrans appropriés et non-inflammables.
4. Des gouttes de laitier en fusion sont émises de l'arc de soudage. Se protéger avec des vêtements de protection libres de l'huile, tels que les gants en cuir, chemise épaisse, pantalons sans revers, et chaussures montantes.
5. Toujours porter des lunettes de sécurité dans la zone de soudage. Utiliser des lunettes avec écrans latéraux dans les zones où l'on pique le laitier.

6. Eloigner les matériaux inflammables ou les recouvrir afin de prévenir tout risque d'incendie dû aux étincelles.
7. Quand on ne soude pas, poser la pince à un endroit isolé de la masse. Un court-circuit accidentel peut provoquer un échauffement et un risque d'incendie.
8. S'assurer que la masse est connectée le plus près possible de la zone de travail qu'il est pratique de le faire. Si on place la masse sur la charpente de la construction ou d'autres endroits éloignés de la zone de travail, on augmente le risque de voir passer le courant de soudage par les chaînes de levage, câbles de grue, ou autres circuits. Cela peut provoquer des risques d'incendie ou d'échauffement des chaînes et des câbles jusqu'à ce qu'ils se rompent.
9. Assurer une ventilation suffisante dans la zone de soudage. Ceci est particulièrement important pour le soudage de tôles galvanisées plombées, ou cadmiées ou tout autre métal qui produit des fumées toxiques.
10. Ne pas souder en présence de vapeurs de chlore provenant d'opérations de dégraissage, nettoyage ou pistilage. La chaleur ou les rayons de l'arc peuvent réagir avec les vapeurs du solvant pour produire du phosgène (gas fortement toxique) ou autres produits irritants.
11. Pour obtenir de plus amples renseignements sur la sûreté, voir le code "Code for safety in welding and cutting" CSA Standard W 117.2-1974.

PRÉCAUTIONS DE SÛRETÉ POUR LES MACHINES À SOUDER À TRANSFORMATEUR ET À REDRESSEUR

1. Relier à la terre le châssis du poste conformément au code de l'électricité et aux recommandations du fabricant. Le dispositif de montage ou la pièce à souder doit être branché à une bonne mise à la terre.
2. Autant que possible, l'installation et l'entretien du poste seront effectués par un électricien qualifié.
3. Avant de faire des travaux à l'intérieur de poste, la débrancher à l'interrupteur à la boîte de fusibles.
4. Garder tous les couvercles et dispositifs de sûreté à leur place.

Mar. '93

V350-PRO

LINCOLN[®]
ELECTRIC

| | Page |
|-----------------------------------------|---------------------|
| Safety | i-iv |
| Installation | Section A |
| Operation | Section B |
| Accessories | Section C |
| Maintenance | Section D |
| Theory of Operation | Section E |
| Troubleshooting and Repair | Section F |
| How to Use Troubleshooting Guide | F-2 |
| Troubleshooting Guide | F-4 |
| Test Procedures | F-15 |
| Replacement Procedures | F-51 |
| Electrical Diagrams | Section G |
| Parts Manual | P-401 Series |

TABLE OF CONTENTS

- INSTALLATION SECTION -

Installation

| | |
|-----------------------------------------|---------|
| Technical Specifications | A-2 |
| Safety Precautions..... | A-3 |
| Stacking..... | A-3 |
| Tilting | A-3 |
| Input Grounding Connections | A-3 |
| Power Cord Connection | A-3 |
| Connection of Wire Feeders..... | A-3/A-4 |
| Cobramatic Connection Instructions..... | A-4 |
| Parallel Operation | A-5 |

V350-PRO



TECHNICAL SPECIFICATIONS - INVERTEC V350-PRO

INPUT AC VOLTAGE & DC OUTPUT

| Product Name | Ordering Information | Input AC Voltage | Rated DC Output Amps/Volt /Duty Cycle | Output Range (continuous) | Weight with Cord | Dimensions HxWxD Voltage | Open Circuit |
|-------------------------------|-----------------------------|-----------------------------------------|-----------------------------------------------|---------------------------|-------------------------------------------|------------------------------------------------------|--------------|
| Invertec V350-PRO 60/50 Hz | K1728-5 Construction | 200 | 350A / 34V / 60% | AMPS 5-425 | Construction (81.0 lbs.) (36.7 kg.) | 14.8" x 13.3" x 27.8"* (373 x 338 x 706*)mm | 80 VDC |
| | K1728-6 Factory | 208-230/ 380-400/ 415-460/ 575 | 300A / 32V /100% | | Factory (81.0 lbs.) (36.7 kg.) | | |
| | K1728-7 Advanced Process | 1 & 3 Phase 60/50 Hz | Advanced Process (81.5 lbs.) (37.0 kg.) | | | | |

* Overall Length Including Handle, 27.8" (706mm)

V350-PRO INPUT CURRENT

Recommended Fuse Sizes Base On The U.S. National Electrical Code And Maximum Machine Outputs

| Input 50/60 Hz | | Output | | Recommended | | Notes |
|----------------|--------|----------------------------|---------------------------|------------------|-----------|--------|
| Voltage | Phases | 300Amps @ 32Volts(100%) | 350Amps @ 34Volts(60%) | Line Cord AWG | Fuse size | |
| 200 | 1 | Not Recommended | Not Recommended | | --- | Note 1 |
| 208 | 1 | 76 | 94 | 2 | 125A | Note 2 |
| 230 | 1 | 69 | 85 | 4 | 125A | Note 2 |
| 380 | 1 | Not Recommended | Not Recommended | | --- | Note 1 |
| 400 | 1 | Not Recommended | Not Recommended | --- | --- | Note 1 |
| 415 | 1 | 41 | 64 | 6 | 80A | Note 2 |
| 460 | 1 | 36 | 42 | 8 | 70A | |
| 575 | 1 | 31 | 37 | 8 | 50A | |
| 200 | 3 | 41 | 50 | 8 | 80A | Note 2 |
| 208 | 3 | 39 | 50 | 6 | 80A | Note 2 |
| 230 | 3 | 36 | 42 | 8 | 70A | |
| 380 | 3 | 23 | 28 | 8 | 50A | |
| 400 | 3 | 22 | 27 | 8 | 50A | |
| 415 | 3 | 22 | 26 | 8 | 50A | |
| 460 | 3 | 19 | 23 | 8 | 50A | |
| 575 | 3 | 16 | 18 | 8 | 35A | |

Note 1. Not rated is indicated by 4-x's in the box on the rating plate.

Note 2. When operating on these inputs, the line cord should be changed to an input conductor of 6 AWG or larger.

OUTPUT CABLES, CONNECTIONS AND LIMITATIONS

Select The output cable size based upon the following chart.

Cable sizes for Combined Length of Electrode and Work Cable (Copper) 75C rated:

| DUTY CYCLE | CURRENT | LENGTH UP TO 200FT.(61m) | 200-250 FT. (61-76m) |
|------------|---------|--------------------------|----------------------|
| 100% | 300 | 1/0 | 1/0 |
| 60% | 350 | 1/0 | 2/0 |

V350-PRO



INSTALLATION

SAFETY PRECAUTIONS

⚠ WARNING



ELECTRIC SHOCK can kill.

- **TURN THE INPUT POWER OFF AT THE DISCONNECT SWITCH BEFORE ATTEMPTING TO CONNECT OR DISCONNECT INPUT POWER LINES, OUTPUT CABLES, OR CONTROL CABLES.**
- Only qualified personnel should perform this installation.
- Connect the green/yellow lead of the power cord to ground per U.S.National Electrical Code.

SELECT SUITABLE LOCATION

The Invertec V350-PRO will operate in harsh environments. Even so, it is important that simple preventative measures are followed in order to assure long life and reliable operation.

- The machine must be located where there is free circulation of clean air such that air movement in the back, out the sides and bottom will not be restricted.
- Dirt and dust that can be drawn into the machine should be kept to a minimum. Failure to observe these precautions can result in excessive operating temperatures and nuisance shutdown.
- Keep machine dry. Shelter from rain and snow. Do not place on wet ground or in puddles.
- **DO NOT MOUNT OVER COMBUSTIBLE SURFACES.**

⚠ CAUTION

Where there is a combustible surface directly under stationary or fixed electrical equipment, that surface shall be covered with a steel plate at least .06" (1.6mm) thick, which shall extend not less than 5.90" (150mm) beyond the equipment on all sides.

STACKING

V350-PRO cannot be stacked.

TILTING

Place the machine directly on a secure, level surface or on a recommended undercarriage. The machine may topple over if this procedure is not followed.

INPUT AND GROUNDING CONNECTIONS

- Only a qualified electrician should connect the Invertec V350-PRO. Installation should be made in accordance with the appropriate National Electrical Code, all local codes and the information detailed below.
- When received directly from the factory, multiple voltage machines are internally connected for 460VAC. If 460VAC is the desired input, then the machine may be connected to the power system without any setup required inside the machine.

- Initial 200VAC - 415VAC and 575VAC operation will require an Input voltage panel setup.
- Open the access panel on the rear of the machine.
- For 200 or 230: Position the large switch to 200-230.
For higher voltages: Position the large switch to 380-575.
- Move the "A" lead to the appropriate terminal.

POWER CORD CONNECTION

A 10 ft. power cord is provided and wired into the machine. Follow the power cord connection instructions.

⚠ CAUTION

• **Incorrect connection may result in equipment damage.**

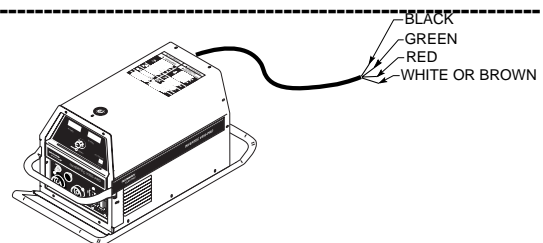

Single Phase Input

Connect green lead to ground per National Electrical Code.

Connect black and white leads to power.

Wrap red lead with tape to provide 600V insulation.

Three Phase Input

Connect green lead to ground per National Electric Code.

Connect black, red and white leads to power.

CONNECTIONS OF WIRE FEEDERS TO V350-PRO

LN-25 Connection Instructions

(Factory, Construction & Advanced Process versions can be connected. **-Not recommended for Pulse Welding with the Advanced Process Model**).

- Turn the Invertec power switch "off".
- Connect the electrode cable to the output terminal of polarity required by electrode. Connect the work lead to the other terminal.
- LN-25 with Remote Control options can be used with the Factory Advanced Process version of the V350. The 6-Pin (K444-1) and 14-pin (K444-2) remotes can be connected directly to the 6-pin & 14-pin MS-style connectors. The 42 Volt Remote Voltage and Output Control (K624-1) Kit can be connected to the V350's 14-pin MS-style connector using Remote Control Cable assembly K627- []. LN-25s with a K431-1 remote kit can be connected to the V350's 14-pin MS-style connector using a K432 cable and K876 adapter. (See connection diagram S19899). Or the K432 cable could be modified with a K867 Universal Adapter Plug (See connection diagram S19405) to connect it to the V350's 14-pin MS-style connector.

V350-PRO



INSTALLATION

LN-7 Connection Instructions

An LN-7 can only be used with the "Factory" & "Advanced Process" versions of the 350-Pro.

- Turn the Invertec power switch "off".
- Connect the K480 control cable from the LN-7 to the 14-pin MS-style connector.
- Connect the electrode cable to the output terminal of the polarity required by electrode. Connect the work lead to the other terminal.
- Set the meter polarity switch on the front of the Invertec to coincide with wire feeder polarity used. The wire feeder will now display the welding voltage.
- If K480 is not available, see connection diagram S19404 for modification of K291 or K404 LN-7 input cable with K867 Universal Adapter Plug.
- If a remote control such as K857 is to be used with the LN-7, the remote can be connected directly to the 6-pin MS-style connector on the front of the Invertec or use a K864 adapter to connect the LN-7 and the remote to the 14-pin MS-style connector. (See connection diagram S19901)

LN-10 Connection Instructions

An LN-10 can only be used with the "Factory" & "Advanced Process" versions of the 350-Pro.

- Turn the Invertec power switch "off"
- Connect the K1505 control cable from the LN-10 to the 14-pin MS-style connector.
- Connect the electrode cable to the output terminal of polarity required by the electrode. Connect the work lead to the other terminal.
- Set the meter polarity switch on the front of the Invertec to coincide with wire feeder polarity used.
- See the LN-10 manual for details on accessing Control DIP Switch

LN-742 Connection Instructions

An LN-742 can only be used with the "Factory" & "Advanced Process" versions of the 350-Pro.

- Turn the Invertec power switch "off"
- Either a K591 or a K593 Input cable assembly is required to connect the LN-742 to the Invertec.
- Connect the control cable from the LN-742 to the 14-pin MS-style connector.
- Connect the electrode cable to the output terminal of the polarity required by electrode. Connect the work lead to the other terminal.
- Set the meter polarity switch on the front of the Invertec to coincide with wire feeder polarity used. The wire feeder will now display the welding voltage.
- If a remote control such as K857 is to be used with the LN-742, the remote can be connected directly to the 6-pin MS-style connector on the front of the Invertec or use a K864 adapter to connect the LN-742 and the remote to the 14-pin MS-style connector.

Cobramatic Connection Instructions

A Cobramatic can only be used with the "Factory" & "Advanced Process" versions of the 350-Pro.

- Turn the Invertec power switch "off"
- Connect the control cable from the Cobramatic to the 14-pin MS-style connector.
- Connect the electrode cable to the output terminal of the polarity required by electrode. Connect the work lead to the other terminal.
- Set the meter polarity switch on the front of the Invertec to coincide with wire feeder polarity used.
- If a remote control such as K857 is to be used with the Cobramatic, the remote can be connected directly to the 6-pin MS-style connector on the front of the Invertec or use a K864 adapter to connect the cobramatic and the remote to the 14-pin MS-style connector.

TIG Module K930-2

The TIG Module connects to the Factory and Advanced Process V350-Pro versions with a K936-1 (9-14 pin) control cable. Connect the K936-1 to the MS-style connector.

The TIG Module can also be used with the V350-Pro Construction version. A K936-4 control cable is required to supply 115VAC to the TIG Module from an external 115VAC supply.

General Instructions for Connection of Wire Feeders to V350-Pro

Wire feeders other than those listed above may be used provided that the auxiliary power supply rating of the V350-Pro is not exceeded. K867 universal adapter plug is required. See connection diagram S24985 on page F-4.

REMOTE CONTROL OF INVERTEC

Remote Control K857, Hand Amptrol K963 and Foot Amptrol K870.

UNDERCARRIAGE MOUNTINGS

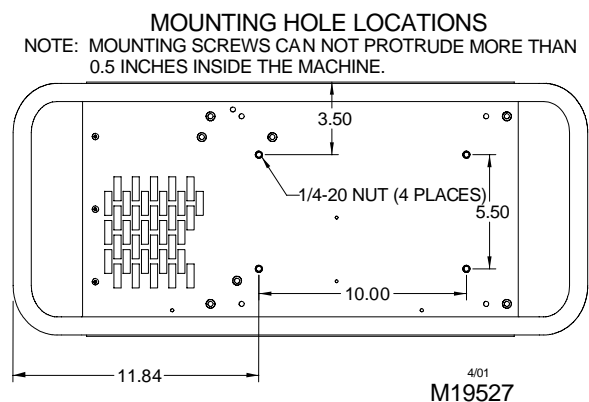

V350-PRO



PARALLEL OPERATION

The V350-Pro can be paralleled in CC mode. For best results, the currents of each machine should be reasonably well shared. As an example, with two machines set up in parallel for a 400 amp procedure, each machine should be set to deliver approximately 200 amps, not 300 amps from one and 100 amps from the other. This will minimize nuisance shutdown conditions. In general, more than two machines in parallel will not be effective due to the voltage requirements of procedures in that power range.

To set machine outputs, start with output control pots and arc control pots in identical positions. Use the output control pots to balance the currents and maintain the desired current. The arc control pots should be kept identical on the two machines.

V350-PRO



V350-PRO



TABLE OF CONTENTS - OPERATION SECTION -

| Operation..... | Section B |
|--------------------------------------------------------------------------|-----------|
| Safety Precautions..... | B-2 |
| General Description..... | B-2 |
| Duty Cycle..... | B-2 |
| Operational Features and Controls | B-2 |
| Weld Mode Select..... | B-3 |
| CC-Stick Soft..... | B-3 |
| CC-Stick Crisp..... | B-3 |
| TIG GTAW | B-4 |
| CV-Wire..... | B-4 |
| CV-Innersheild..... | B-4 |
| Advanced Process Panel..... | B-5 |
| Controls | B-6 |
| Electrode Material..... | B-6 |
| Hot Start & Arc Control..... | B-6 |
| Weld Mode Details..... | B-7 |
| Pulse Programs | B-8 |
| Lower Case Front | B-9 |
| CV Modes..... | B-9 |
| TIG Mode | B-9 |
| CC-Stick Modes..... | B-9 |
| Types of Remote Output Control..... | B-9 |
| Types of Remote Weld Terminal Control | B-9 |
| Auxiliary Power | B-10 |
| Limitations..... | B-10 |
| Recommended Processes..... | B-10 |
| Descriptions of Special Welding Processes Available on this Machine..... | B-11 |

V350-PRO



SAFETY PRECAUTIONS

⚠ WARNING



- ELECTRIC SHOCK can kill.**
- Do not touch electrically live parts or electrode with skin or wet clothing.
 - Insulate yourself from work and ground.
 - Always wear dry insulating gloves.



- FUMES AND GASES can be dangerous.**
- Keep your head out of fumes.
 - Use ventilation or exhaust to remove fumes from breathing zone.



- WELDING SPARKS can cause fire or explosion.**
- Keep flammable material away.
 - Do not weld on closed containers.



- ARC RAYS can burn eyes and skin.**
- Wear eye, ear and body protection.

See additional warning information at front of this operators manual.

GENERAL DESCRIPTION

The Invertec V350-Pro offers multi-process CV, CC, and DC welding and is rated 350 amps, 34 volts at a 60% duty cycle. The V350-Pro is available in either a Construction version (no wire feeder connection and auxiliary power) and a Factory & Advanced Process versions (includes wire feeder connection and related power)

- The factory model is the construction model with the addition of the Wire Feeder/Remote Adapter.
- In this form, the V350-Pro provides the hardware to power and connect to 24, 42 or 115 VAC wire feeders.
- The advanced process model is the factory model with an advanced process panel installed in place of the standard mode panel. In this form, the V350-Pro provides access to the 5 standard weld modes (Stick Soft, Stick Crisp, TIG, CV-Wire, CV-Innershield), gouge, constant power and pulse MIG weld modes.

DUTY CYCLE

The V350-Pro is rated at 350 amps, 60% duty cycle (based on a 10 minute cycle). It is also rated at 300 amps, 100% duty cycle.

OPERATIONAL FEATURES and CONTROLS:

UPPER CONTROL PANEL

1. AMPS Meter

- Prior to STICK or TIG operation (current flow), the meter displays preset current value (+/- 2 amps or +/- 3%, whichever is greater).
- Prior to CV operation, the meter displays four dashes indicating non-presetable AMPS.
- During welding, this meter displays actual average amps.
- After welding, the meter holds the actual current value for 5 seconds. Output adjustment while in the "hold" period results in the "prior to operation" characteristics stated above. The displays blink indicating that the machine is in the "Hold" period.

2. VOLT METER

- Prior to CV operation (current flow), the meter displays desired preset voltage value (+/- .5V).
- Prior to STICK or TIG operation, the meter displays the Open Circuit Voltage of the Power Source or four dashes if the output has not been turned on.
- During welding, this meter displays actual average volts.
- After welding, the meter holds the actual voltage value for 5 seconds. The displays blink indicating that the machine is in the "Hold" period.
- Output adjustment while in the "hold" period results in the "prior to operation" characteristics stated above.

3. OUTPUT CONTROL

- Output control is conducted via a single turn potentiometer.
- Adjustment is indicated by the meters as stated above.
- When in TIG modes, this control sets the maximum welding current. Full depression of a foot or hand Amptrol results in the preset level of current.

4. WELD TERMINALS-REMOTE / ON

- Two status lights indicate the location of trigger control as determined by the "WELD TERMINALS" push button.
- If trigger control is local "weld terminals on", the ON display will be lit.
- If trigger control is remote "weld terminals remotely controlled", the REMOTE display will be lit.

V350-PRO



OPERATION

- The unit will power up in "pre-determined preferred" trigger modes.

STICK = ON

CV = REMOTE

TIG = REMOTE if remote output controls are attached to the machine.

TIG = ON if remote output controls are not attached to the machine.

For all versions, these trigger modes can be over-ridden (switched) with the WELD TERMINALS push button. When changed, the unit will power up in the configuration it was in when it was last powered down.

5. THERMAL

- This status light indicates when the power source has been driven into thermal overload. If the output terminals were "ON", the "ON" light will blink indicating that the output will be turned back on once the unit cools down to an acceptable temperature level. If the unit was operating in the "REMOTE" mode, the trigger will need to be opened before or after the thermal has cleared and closed after the machine has cooled down to an acceptable temperature to establish output.

6. CONTROL-REMOTE / LOCAL

- Two status lights indicate the location of output control as pre-determined by the power sources auto-configure system.
- The LOCAL display will be lit when control is at the power source.
- The REMOTE display will be lit when a remote pot/control is detected.

These Output Control configurations can be overridden (switched) with the CONTROL push button. When changed, the unit will power up in the configuration it was in when it was last powered down.

7. WELD MODE SELECT - FACTORY AND CONSTRUCTION (See Figure B.1)

The Mode Control button selects from the following welding modes.

CC-STICK SOFT: The Stick Soft process features continuous control ranging from 5 to 425 amps. This mode was intended for most SMAW applications, and Arc Gouging.

- Arc Gouging: Setting the output of the Stick Soft mode to 425 amps will enable the arc-gouging mode. The actual output current will depend on the size of carbon used. The recommended maximum size carbon is 5/16".
- The Hot Start control regulates the starting current at arc initiation. Hot Start can be adjusted from minimum (0), with no additional current added at arc start, to maximum (10), with double the preset current or 425 amps (max of machine) added for the first second after arc initiation.
- The Arc Control regulates the Arc Force to adjust the short circuit current. The minimum setting (-10) will produce a "soft" arc and will produce minimal spatter. The maximum setting (+10) will produce a "crisp" arc and will minimize electrode sticking.

CC-STICK CRISP: The Stick Crisp mode features continuous control from 5 to 425 amps. This mode was intended primarily for pipe welding applications.

- The Hot Start control regulates the starting current at arc initiation. Hot Start can adjust starting current up or down by 25% of the preset value. The recommended setting for Hot Start is 5 where the initial current is equal to the preset current.

Hidden Middle Control Panel – Mode Panel

FIGURE B.1.

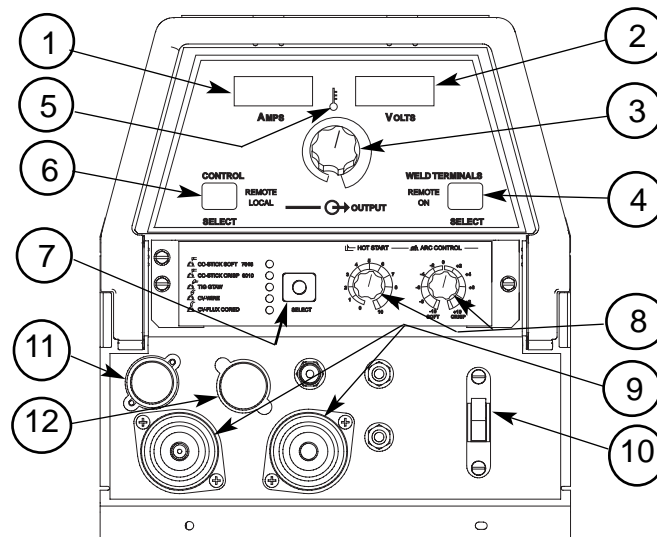

V350-PRO

LINCOLN
ELECTRIC

- The Arc Control regulates the Arc Force to adjust the short circuit current. The minimum setting (-10) will produce a "soft" arc and will produce minimal spatter. The maximum setting (+10) will produce a "crisp" arc and will minimize electrode sticking.

TIG GTAW: The TIG mode features continuous control from 5 to 425 amps. The TIG mode can be run in either the TIG touch start or high frequency (optional equipment required) assisted start mode.

- The Hot Start control selects the starting mode desired. A setting of less than 5, the TIG lift start mode is selected. The OCV is controlled below 10v and the short circuit "TIG touch" current is maintained at 25 amps independent of the preset current. When the tungsten is lifted, an arc is initiated and the output is regulated at the preset value. Hot start settings between 0 and 5 regulate the arc initiation current. A setting of 5 results in the most positive arc initiation. A setting of 0 reduces hot start.
- Hot Start settings between 5 and 10, select high frequency assisted starting TIG mode. In this range, the OCV of the machine is controlled between 50 and 70 volts. If using the Lincoln K930-1 TIG Module, set the Hot start to 10 for maximum OCV.
- The Arc Control is not used in the TIG mode.

TIG SOLENOID OPTION

The Solenoid only operates when the V350 is in the TIG mode. If the Weld Terminals are in "Remote" then the solenoid will open when the arc start switch is closed. The solenoid will close after the arc switch has been opened and the post flow time expired.

If the Weld Terminals are turned "ON", then the solenoid will open when the electrode is touched to the work. The electrode needs to remain in contact with the work to allow for gas coverage before attempting to start the arc. The solenoid will close after the arc has been broken and the post flow time expired.

CV-WIRE: The CV-WIRE mode features continuous control from 10 to 40 volts. The mode was intended for most GMAW, FCAW, and MCAW applications.

- The Hot Start control is not used in the CV-WIRE mode.
- The Arc Control regulates pinch effect. At the minimum setting (-10), minimizes pinch and results in a soft arc. Low pinch settings are preferable for welding with gas mixes containing mostly inert gases. At the maximum setting (+10), maximizes pinch effect and results in a crisp arc. High pinch settings are preferable for welding FCAW and GMAW with CO₂.

CV-INNERSHEILD: The CV-INNERSHEILD mode features continuous control from 10 to 45 volts. This mode was designed for self-shielded flux cored wires that require tight voltage control.

- The Hot Start control is not active in the CV-FLUX CORED mode.
- The Arc Control regulates pinch effect. At the minimum setting (-10), minimizes pinch and results in a soft arc. At the maximum setting (+10), maximizes pinch effect and results in a crisp arc. Most self-shielded wires work well at an Arc Control setting of 5.

V350-PRO



7A. ADVANCED PROCESS PANEL

(See Figure B.2)

To program Welding modes. **SELECT** knob is used to Scroll through all Welding modes. The **MEMORY** button is used to store and access Welding modes into locations M1 thru M8.

Modes:

In addition to the 5 welding modes described in **SECTION 7**, the Advanced Process Panel allows you to select the Following additional modes.

• Power Mode

In the Power Mode;

The work point will be in the Volts window. The Amp window will have **CP** displayed indicating Constant Power. Once current starts flowing and during the 5 second "Hold" feature the displays will show Volts and Amps respectively. Refer to the detailed explanation at the end of this section.

• Gouge

Air Carbon Arc Cutting (CAC-A) is a physical means of removing base metal or weld metal by using a carbon electrode, an electric arc and compressed air.

• Pulsed Modes

In Pulse Modes;

The work point will be in the Amps window and should be set close to the wire feed speed of the wire feeder in inches per minute. The Volts window will have **SPd** displayed indicating Wire Feed Speed. Once current starts flowing and during the 5 second "Hold" feature the displays will show amps and volts.

Pulse Mode features that are displayed while selecting a Welding pulse mode are listed below;

Steel - .030, .035, .045, .052 – Argon Blends

Stainless Steel - .030, .035, .045 – Argon Blends & Helium/Argon Blends

Aluminum - .035, 3/64, 1/16 – 4043 & 5356

Metal Core - .045, .052 – Argon Blends

Nickel - .035, .045 – Argon/Helium blends

Refer to the detailed explanation at the end of this section.

ADVANCED PROCESS PANEL VERSION

FIGURE B.2

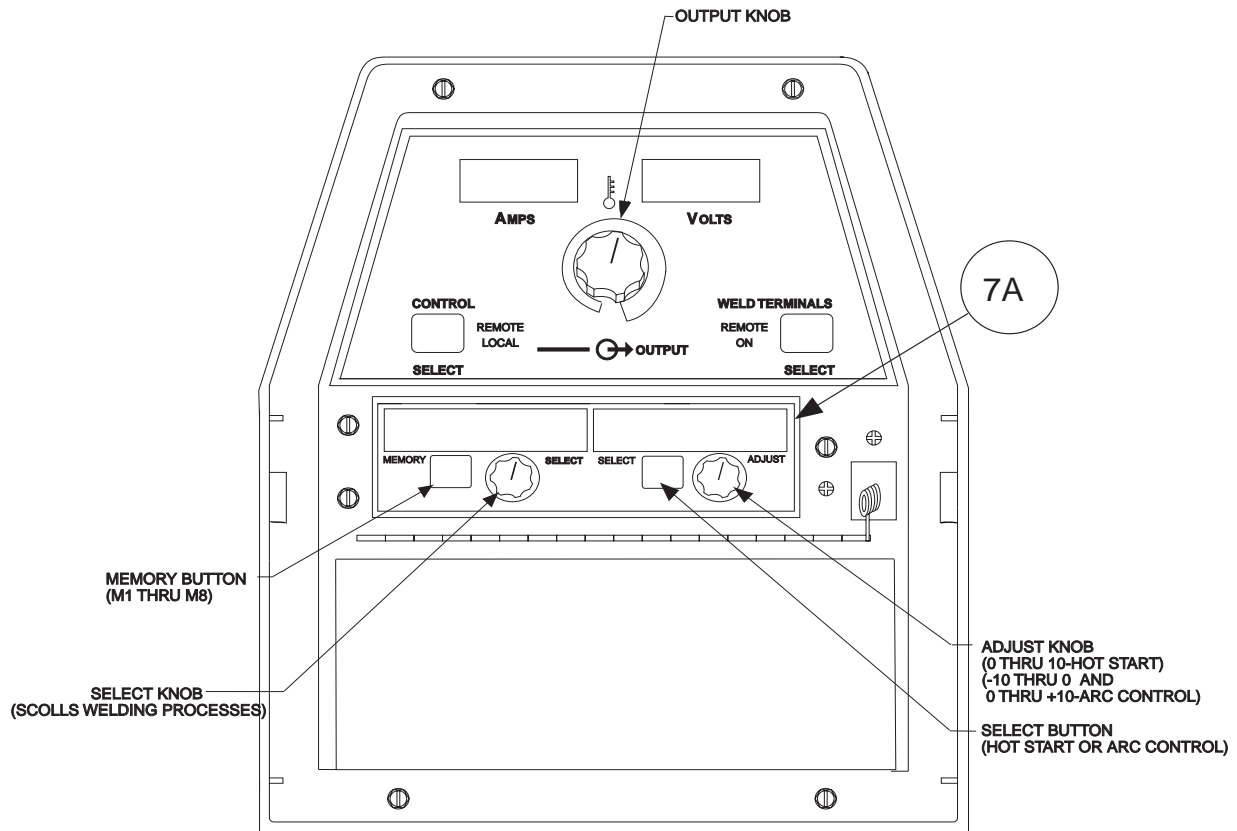

V350-PRO

LINCOLN[®]
ELECTRIC

OPERATION

CONTROLS: (See Figure B.2.)

The **MEMORY button** and **SELECT knob** are used together to select a welding process and store it in memory (M1 thru M8). The **SELECT knob** scrolls through the, welding process modes and memory M1 thru M8. The **MEMORY button** stores the welding process in memory.

- **SELECT button** (The right button) selects between the "Hot Start" or "Arc Control". The < will indicate the active feature shown below.

Right Digital Window
 "Hot Start" (-10 to 0 +10)
 "Arc Control" (0 to 10) <

- The **ADJUST knob** adjusts the desired settings for the Hot Start or Arc Control feature that is active.

WELDING PROCESS MODES AVAILABLE

Stick SMAW, TIG GTAW
 Gouge CAG, CV MIG GMAW
 CV Flux Core, Pulse MIG

ELECTRODE MATERIAL

Steel, Metal Core, Stainless, Aluminum, Nickel

EXAMPLE OF SAVING WELDING MODES TO MEMORY

The following example is how to select **Pulse MIG** using .035 steel and store it into memory.

1. Turn the **Select knob** until welding process is displayed.

| LEFT WINDOW | RIGHT WINDOW |
|-------------|--------------|
| Pulse MIG | Argon Blends |
| Steel .035 | |

2. Wait two seconds and the right window will display Arc Control on the second line on the right side.

| | |
|------------|-----------------|
| Pulse MIG | Argon Blends |
| Steel .035 | Arc Cntrl ### < |

3. **SPd** is displayed in the upper right **Volts** window. The left **Amps** window matches the desired wire feed speed that is set on the wire feeder. Adjust the **Output knob** until desired number is displayed.

4. Start welding. If the arc length is too short turn the **Output knob** up. If the arc length is too long turn the **Output knob** down.

The Arc Control which is displayed in the right digital window can be used to fine-tune the arc length and characteristics.

5. After all adjustments have been made press and hold the **Memory button** until the display changes. The right and the left window will display what memory to save in, lets say M1. To store in M1 push the **Memory button** again to save the Pulse Mig mode to memory M1.

6. The display in the digital windows will read as follows:

| | | |
|-------|-----------|---------------|
| M1 | Pulse MIG | Argon Blends |
| Steel | .035 | Arc Cntrl 1.2 |

7. Saving or entering a second welding mode to a memory, M2. Turn the **Select knob** until the desired welding process mode is displayed in right digital window. Then follow steps 1 thru 6.

Press the **Memory button** till the digital window reads,

Save to MEM
M2

Press the **Memory button** again and the New Welding process is saved in M2.

8. Adjust the output control to the correct wire feed setting and the V350-PRO is ready to weld again. (Note: The wire feed speed setting is not stored in memory and will need to be reset.)

9. Adjust the Arc Control and note that the M1 goes away indicating that the V350-PRO settings no longer match what is stored in memory. Going back to the original settings will not bring the M1 back. You will need to push the **Memory button** to recall the original settings in M1.

Note: After all memory's M1 thru M8 are used and the welder needs to store another welding process, a new welding process will overwrite what was originally in the memory and will read,

Save to MEM
M1 Overwrite

M1 which stored Pulse Mig is Overwritten with the new welding process.

LN-10/DH-10 Wire Feeder Compatibility Note:

The LN-10 and DH-10 feeders can be used to pulse weld and in the power mode with the panel. The displays on the LN-10 & DH-10 do not show the wire feed speed or power.

8. **HOT START** and **ARC CONTROL** features have different functions depending on the welding Mode that is active. Each feature is described under the welding mode heading. (See Item 7 or 7.A for specified Mode Operations) (See Figure B.1 or B.2)

V350-PRO



OPERATION

WELD MODE DETAILS:

| Mode | Range | Comments |
|----------------------------------------------|-------------------|----------------------------------------------------------------------------------------------------------------------------------------------------------------------------------------------------------------------------------------------------------------------------------------------------------------------------------------------------------------------------------------|
| Stick Soft | 5 - 425 amps | The stick soft mode is the best selection for general stick applications. Arc Control = Arc Force Hot Start = Initial hot start current (min = start a match set amps, Max. = greatest hot start current) During hot start, arc force is set at high and is fast response. For gouging applications: Turn current up to 425 amps. |
| Stick Crisp | 5 - 425 amps | The stick crisp mode features an aggressive arc force routine well suited for Exx10, Exx11 series electrodes. Arc Control = Arc Force Hot Start = Initial hot start current (Mid range = welding current and will vary up and down with knobcontrol.) During hot start, arc force is set at high and is fast response. For gouging applications: Turn current up to 425 amps. |
| GTAW (Tig mode) | 5 - 425 amps | The tig mode produces a soft, steady constant current waveform for either touch start or high frequency assisted start DC GTAW applications. Hot Start = Min to Mid range = Touch start with low OCV Mid to Max range = High frequency assisted starting with adjustable OCV up to 70 volts. |
| GMAW - CV | 10 - 45 volts | The GMAW - CV mode is the best selection for general MIG welding, Metal core, and gas shielded applications. Arc Control = Pinch (Min = min pinch, softest arc), (Max = max pinch, crispest arc) |
| FCAW-SS | 10 - 45 volts | The FCAW-SS mode is designed for Self Shielded Innershield products that require tight voltage control. For example; the NR 203 series or NR 207) Arc Control = Pinch (Min = min pinch, softest arc), (Max = max pinch, crispest arc,) |
| ADVANCED PULSE PANEL WELDING PROGRAMS | | |
| Gouging | 60 - 425 amps | The gouging mode is a low power version of other Lincoln welding equipment gouging programs, for example a PowerWave 455. |
| GMAW - Power | 1 - 18 (No Units) | Refer to the detailed explanation at the end of this section. This mode does not allow preset voltage. In the short arc GMAW mode, the set KW will not equal the actual Volts * Amps. The set power is regulated only when an arc is present. During shorting, the output is allowed to increase to clear the short. |

V350-PRO



OPERATION

PULSE PROGRAMS:

| MODE | Range (IPM*) | COMMENTS |
|-----------------------------------|--------------|-------------------------------------------------------------------------------------------------------------------------------------------------------------------------------------------------------------------------------------------------------------------------------------------------------------------------------------------------------------------------------------------------------------------------------------------------------------------------------------------------------------------------------------------------------------------------------------------------------------------------------------------------------------------------------------------------------------------------------------------------------------------------------------------------------------------------------------------------------------------------------------------------------------------------------------------------------------------------------------------------------------------------------------------------------------------------------------------------------------------------------------------------------------------------------------------------------------------------------------------------------------------------------------------------------------------------------------------------------------------------------------------------------|
| .030 Steel | 65 - 1200 | <p>The V350 pulse programs are non-synergic and allow independent control of the wire feed speed (at the wire feeder) and the arc length. The Output Control Knob on the V350, adjusts an "SPD" value. Similar to trim, the "SPD" value indicates the relative arc length setting. The "SPD" value displayed on the V350 may not match the actual wire feed speed! The value of "SPD" is meant to be a point at which to set the arc length relative to the wire feed speed and should be set the same as actual speed for a starting point. Depending on the application, the "SPD" value can be adjusted to obtain the desired arc length. Refer to the detailed explanation at the end of this section.</p> <p>The operation of the Arc Control knob on the V350 is similar to the PowerWave series. As Arc Control is increased, the frequency is increased and the background reduced. Decreasing Arc Control will reduce frequency and increase background current. Arc Control acts to fine tune the arc plasma to the specific application.</p> <p>Preferred gas selections:</p> <p>Steel Argon Blends = Argon with CO2 additions from 2 to 20 % or Oxygen additions from 2 to 5%.</p> <p>Stainless Argon Blends = Argon with Oxygen additions up to 2%.</p> <p>Stainless He Ar CO2 = ~ 90% Helium, 7 1/2 % Argon 2 1/2 CO2</p> <p>Aluminum 100% Argon</p> |
| .035 Steel | 55 - 800 | |
| .045 Steel | 50 - 700 | |
| .052 Steel | 75 - 550 | |
| .045 Metal Core | 50 - 650 | |
| .052 Metal Core | 50 - 500 | |
| .030 Stainless Ar Blends | 85 - 770 | |
| .030 Stainless He Ar CO2 | 110 - 770 | |
| .035 Stainless Ar Blends | 65 - 770 | |
| .035 Stainless He Ar CO2 | 75 - 770 | |
| .045 Stainless Ar Blends | 50 - 600 | |
| .045 Stainless He Ar CO2 | 50 - 600 | |
| .035 Aluminum 4043 | 100 - 700 | |
| .035 Aluminum 5356 | 115 - 740 | |
| 3/64 Aluminum 4043 | 80 - 550 | |
| 3/64 Aluminum 5356 | 85 - 700 | |
| 1/16 Aluminum 4043 | 75 - 325 | |
| 1/16 Aluminum 5356 | 75 - 450 | |
| | | |
| .035 Nickel Alloys (Non Adaptive) | 80 - 700 | <p>The Nickel Alloy pulse programs are non adaptive. The operator sets the output control knob to deliver the correct arc length at desired wire feed speed and stick out. While welding, the operator manipulates the stick out to maintain the correct arc length. This method of operation produces very stable arc performance considering the nature of nickel alloys.</p> <p>Preferred gas: Argon/Helium Blends = for the best results add helium to the argon base from 0-25%.</p> |
| .045 Nickel Alloys (Non Adaptive) | 75 - 550 | |
| | | |
| PULSE ON PULSE | | |
| .035 4043 (4x Pulse on Pulse) | 120 - 600 | <p>Arc Control = Pulse on Pulse frequency. For faster travel speed welds, the arc control should be increased.</p> <p>For larger puddle, slower travel speeds, the arc control should be decreased. Refer to the detailed explanation at the end of this section.</p> |
| 3/64 4043 (4x Pulse on Pulse) | 85 - 400 | |
| .035 5356 (5x Pulse on Pulse) | 130 - 700 | |
| 3/64 5356 (5x Pulse on Pulse) | 100 - 550 | |
| | | |

*IPM (INCHES PER MINUTE)

V350-PRO



OPERATION

LOWER CASE PANEL

The output studs, line switch and remote connector are located on the lower case front.

9. Both terminals are "Twist-Mate" connectors.
The Negative terminal is configured to accept the pass through gas system.
10. The **METER POLARITY switch** is located above the output connectors. The switch provides a work connection for wire feeder voltmeters. Place the switch in the position of the electrode polarity indicated by the decal. **The switch does not change the welding polarity.**
11. **6-pin MS-style** connector for remote control.
12. **14-pin MS-style** connector for wire feeder connection and remote control.

REMOTE CONTROL of the OUTPUT CONTROL and WELD TERMINALS

The Invertec V350-Pro has auto sensing of remote output controls. If after connecting or removing a remote, the Invertec V350-Pro did not configure the way you would like the local or remote control settings can be changed by pushing the OUTPUT CONTROL or WELD TERMINAL button. (A user cannot select between the 6 and 14 pin MS-style connectors.)

CV modes

- The remote will default to the 14-pin MS-style connector if a remote is connected. If no remote is connected to the 14-pin MS-style connector then the remote will default to the 6-pin MS-style connector if a remote is connected to it.
- In all of the CV modes, the WELD TERMINAL control will default to REMOTE.

TIG mode

- The remote will default to the 6-pin MS-style if a remote control is connected to the 6-pin MS-style and to the 14-pin MS-style connector. If a remote is not connected to the 6-pin MS-style connector then the remote will default to the 14-pin MS-style connector if a remote is connected.
- If a remote control is connected to any of the MS-style connectors the WELD TERMINAL control will default to REMOTE. If there are not any remote control devices attached the WELD TERMINAL control will default to ON.

CC-Stick modes

- The remote will default to only the 6-pin MS-style connector if a remote is connected to it.
- The WELD TERMINAL control will default to ON with or without a remote connected.

Types of Remote OUTPUT CONTROL

- The Invertec V350-Pro's Output Control can be controlled by either a potentiometer connected between 77 & 75 with the wiper connected to 76 or a 0V to 10V DC supply connected between 76 & 75. (76 needs to be positive)
- 14-Pin Ms-style connector lead 75 is pin G, lead 76 is pin F and lead 77 is pin E.
- 6-Pin Ms-style connector lead 75 is pin C, lead 76 is pin B and lead 77 is pin A.

Potentiometer Control

- The total resistance should be between 2000 ohms (2K) and 10,000 ohms (10K)
- The machine output will be at minimum when lead 76 (wiper) is at the end of the potentiometer that is connected to 75. The machine's output will increase as the wiper of the potentiometer is moved to the end that is connected to 77. (Note: In TIG mode, moving the lead 76 (wiper) to lead 77 would produce the current that has been set by the Invertec V350-Pro's front panel Output Control.)
- Remotes of this type offered by Lincoln Electric are the K857, K812 and K870.

Voltage Control

- The supply must be an isolated supply. (Not referenced to earth ground, any auxiliary power from the Invertec V350-Pro or the welding output) The supply should be capable of supplying at least 20mA.
- 0 volts supplied to 76 will set the Invertec V350-Pro to minimum output for the mode that has been selected while 10 volts supplied to 76 will set the Invertec V350-Pro to the maximum output for the mode. (Note: In TIG mode, 10 volts supplied to lead 76 would produce the current that has been set by the Invertec V350-Pro's front panel Output Control.)

Types of Remote WELD TERMINAL Control

- The Invertec V350-Pro's Weld Terminals can be controlled from each of the MS-style connectors. The circuit has a nominal OCV of 15VDC and requires a dry contact closure (less than 100 ohms) to activate the output of the Invertec V350-Pro.
- 14-Pin MS-style connector, the Weld Terminals are controlled from pin C (lead 2) and pin D (lead 4). Pin C is positive.
- 6-Pin MS-style connector, the Weld Terminals are controlled from pin D (lead 2) and pin E (lead 4). In the 6-pin MS-style connector pin D is positive.

V350-PRO



AUXILIARY POWER

- 115VAC, 42VAC and 24VAC power is available from the 14-pin MS-style connector. The Construction model of the Invertec V350-Pro does not have the 14-pin MS-style connector) These supplies are intended to supply power for auxiliary equipment like wire feeders and the TIG Module.
- 115VAC supply is rated at 2 amps and is protected by a 3.5 amp breaker.
- 42 VAC supply is rated at 5.5 amps and is protected by a 6 amp breaker.
- 24 VAC supply is rated at 5.5 amps and is protected by a 6 amp breaker.

LIMITATIONS

- The V350-Pro is not recommended for processes other than those listed.
- The V350-Pro can only be used with the recommended equipment and options.

RECOMMENDED PROCESSES

Properly equipped, the Invertec V350-Pro supports GMAW-P, FCAW, SMAW, GTAW and CAC-A processes for a variety of materials, including mild steel, stainless steel, cored wires, and aluminum.

V350-PRO



OPERATION

SPECIAL WELDING PROCESSES AVAILABLE ON THIS MACHINE

POWER MODE™

The Power Mode™ process was developed by Lincoln to maintain a stable and smooth arc at low procedure settings which are needed to weld thin metal without pop-outs or burning-through. For Aluminum welding, it provides excellent control and the ability to maintain constant arc length. This results in improved welding performance in two primary types of applications.

- Short Arc MIG at low procedure settings.
- Aluminum MIG welding.

Power Mode™ is a method of high speed regulation of the output power whenever an arc is established. It provides a fast response to changes in the arc. The higher the Power Mode Setting, the longer the arc. If a welding procedure is not established, the best way to determine the Power Mode Setting is by experimentation until the desired output result is established.

In the Power Mode variables need to be set:

- Wire Feed Speed
- Output
- Arc Control

Setting up a Power Mode procedure is similar to setting a CV MIG procedure. Select a shielding gas appropriate for a short arc process.

- For steel, use 75/25 Ar/CO2 shield gas.
- For Stainless, select a Helium blend Tri-Mix.
- For Aluminum, use 100% Ar.

Start by setting the wire feed speed based upon material thickness and appropriate travel speed. Then adjust the Output knob as follows:

- For steel, listen for the traditional “frying egg” sound of a good short-arc MIG procedure to know you have the process set correctly.
- For aluminum, simply adjust the Output knob until the desired arc length is obtained.

Note the Volts display is simply a relative number and DOES NOT correspond to voltage.

Some procedure recommendations appear in the table below.

Recommended Welding Procedures for Power Mode

| MATERIAL | Aluminum 4043 | Aluminum 5356 | Mild Steel | Mild Steel | Mild Steel | Mild Steel | Mild Steel | Mild Steel | Mild Steel | Stainless Steel | Stainless Steel |
|------------------------------------------------|---------------|---------------|----------------------|---------------------------|----------------------|---------------------------|----------------------|---------------------------|---------------------------|-----------------|-----------------|
| WIRE | E4043 | E5356 | L56 | L56 | L56 | L56 | L56 | L56 | L56 | E308L | E308L |
| WIRE SIZE | 0.035 | 0.035 | 0.025 | 0.025 | 0.030 | 0.030 | 0.035 | 0.035 | 0.035 | 0.030 | 0.035 |
| GAS | 100% Ar. | 100% Ar. | 100% CO ₂ | 75/25% Ar/CO ₂ | 100% CO ₂ | 75/25% Ar/CO ₂ | 100% CO ₂ | 75/25% Ar/CO ₂ | 75/25% Ar/CO ₂ | Tri-mix | Tri-mix |
| MATERIAL THICKNESS WFS / POWER MODE SETTING | 22 ga. | 125 / 2.25 | 125 / 1.75 | Not Recommended | 100 / 0.8 | Not Recommended | 90 / 1.0 | | | | |
| | 20 ga. | 150 / 2.5 | 150 / 2.3 | 120 / 1.0 | 120 / 1.0 | 100 / 0.7 | 100 / 1.0 | | | 80 / 1.5 | 50 / 0.5 |
| | 18 ga. | 200 / 3.75 | 200 / 3.0 | 140 / 1.7 | 140 / 1.5 | 110 / 1.5 | 110 / 1.5 | 100 / 2.5 | 100 / 2.5 | 110 / 2.0 | 110 / 2.0 |
| | 16 ga. | 300 / 7.75 | 300 / 6.85 | 190 / 2.0 | 190 / 2.0 | 125 / 2.0 | 125 / 2.0 | 125 / 3.0 | 125 / 3.0 | 140 / 2.5 | 130 / 2.7 |
| | 14 ga. | 400 / 9.0 | 400 / 7.5 | 260 / 3.0 | 260 / 3.0 | 160 / 2.3 | 160 / 2.3 | 160 / 3.8 | 160 / 3.5 | 210 / 3.0 | 190 / 3.5 |
| | 12 ga. | 450 / 9.5 | 450 / 8.0 | 330 / 5.0 | 330 / 4.5 | 230 / 3.5 | 230 / 3.5 | 200 / 5.0 | 200 / 4.5 | 270 / 5.0 | 230 / 6.0 |
| | 10 ga. | 500 / 10.0 | 500 / 8.5 | | | 300 / 6.0 | 300 / 6.0 | 240 / 6.5 | 240 / 7.0 | 325 / 6.5 | 300 / 7.0 |
| | 3/16 | 600 / 11.25 | 600 / 9.5 | | | 400 / 7.5 | 400 / 7.0 | | | | |
| | 1/4 | | 700 / 11 | | | | | | | | |

V350-PRO



OPERATION

PULSE WELDING (GMAW-P)

The pulsed-arc process is, by definition, a spray transfer process wherein spray transfer occurs in pulses at regularly spaced intervals. In the time between pulses, the welding current is reduced and no metal transfer occurs.

Pulsed-arc transfer is obtained by operating a power source between low and high current levels. The high current level or "pulse" forces an electrode drop to the workpiece. The low current level or "background" maintains the arc between pulses. (See Figure below).

Pulsed MIG is an advanced form of welding that takes the best of all the other forms of transfer while minimizing or eliminating their disadvantages. Unlike short circuit, pulsed MIG does not create spatter or run the risk of cold lapping. The welding positions in pulsed MIG are not limited as they are with globular or spray and its wire use is definitely more efficient. Unlike the spray arc process, pulsing offers controlled heat input that allows better welding on thin materials, lower wire feed speeds and leads to less distortion and improved overall quality and appearance. This is especially important with stainless, nickel and other alloys that are sensitive to heat input.

In **GMAW-P mode**, arc control adjusts the background current and frequency of the wave. When arc control goes up, the frequency increases thus increasing the droplet transfer.

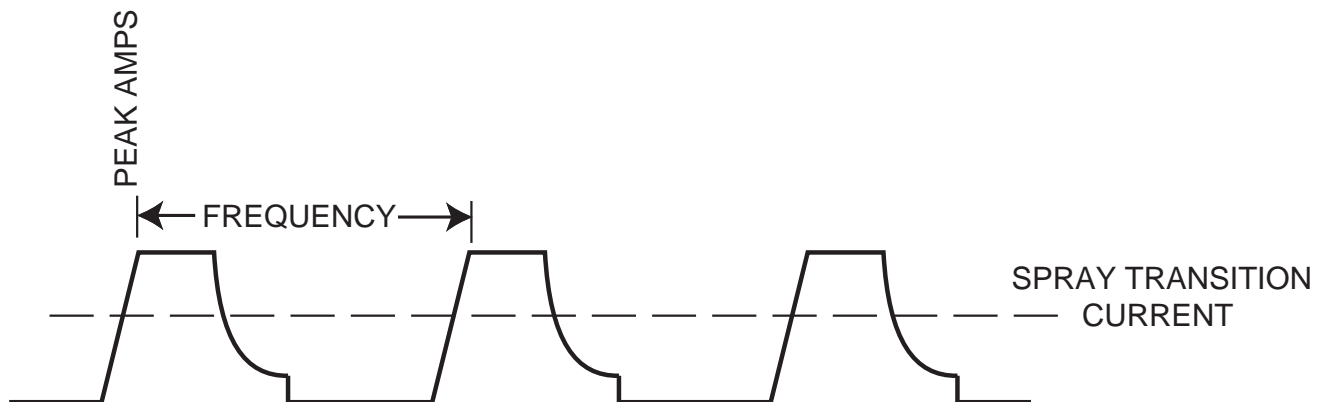
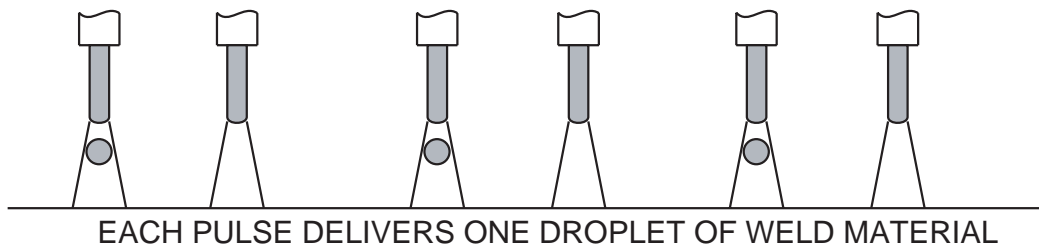

V350-PRO

LINCOLN[®]
ELECTRIC

OPERATION

PULSE-ON-PULSE™ (GMAW-PP)

Pulse on Pulse™ is a Lincoln process specifically designed for use in welding relatively thin (less than 1/4" thick) aluminum (See the table below). It gives weld beads with very consistent uniform ripple.

In Pulse on Pulse modes, two distinct pulse types are used, instead of the single pulse type normally used in GMAW-P. A number of high energy pulses are used to obtain spray transfer and transfer metal across the arc. Such pulses are shown in the figure below. After a number "N" of such pulses, depending on the wire feed speed used, an identical number "N" of low energy pulses are performed. These low energy pulses, shown in the figure below, do not transfer any filler metal across the arc and help to cool the arc and keep the heat input low.

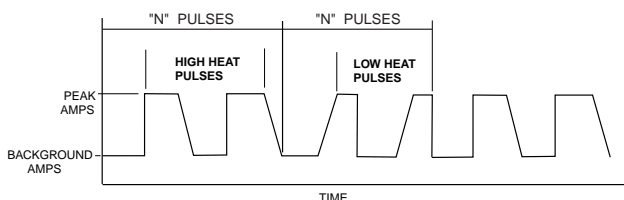

The Peak Current, Background Current, and Frequency are identical for the high energy and low energy pulses. In addition to cooling the weld down, the major effect of the low energy pulses is that they form a weld ripple. Since they occur at very regular time intervals, the weld bead obtained is very uniform with a very consistent ripple pattern. In fact, the bead has its best appearance if no oscillation of the welding gun ("whipping") is used. (See the figure below)

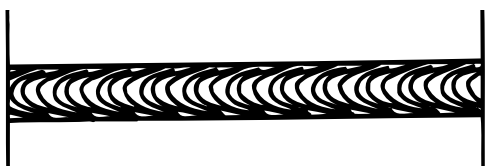

When Arc Control is used in the Pulse on Pulse modes, it does the same things it does in the other pulsed modes: decreasing the Arc Control decreases the droplet transfer and weld deposition rate. Increasing the Arc Control increases the droplet transfer and weld deposition rate. Since Arc Control varies weld droplet transfer rate, the Arc Control can be used to vary the ripple spacing in the weld bead.

BENEFITS OF PULSE ON PULSE FROM LINCOLN ELECTRIC

- Excellent appearance of the weld bead
- Improved cleaning action
- Reduced porosity

Table B.2 shows WFS and Trim settings for common aluminum types and wire sizes when welding with Pulse-on-Pulse. The welds made to obtain the values in the table were fillet welds in the flat position. The values in the table can be helpful as a starting point to establish a welding procedure. From there, adjustments need to be made to set the proper procedure for each specific application (out-of-position, other types of joints, etc.).

The comments on the table below show values of WFS below which it is not recommended to weld. The reason is, that below these values the weld transfer will change from a spray arc to a short-arc, which is not advisable when welding aluminum.

WELDING PROCEDURES FOR PULSE-ON-PULSE

| MATERIAL | Aluminum 4043 | Aluminum 4043 | Aluminum 5356 | Aluminum 5356 |
|--------------------------------------------|-------------------------------|-------------------------------|-------------------------------|-------------------------------|
| GAS | 100% Ar. | 100% Ar. | 100% Ar. | 100% Ar. |
| WIRE | E4043 | E4043 | E5356 | E5356 |
| WIRE SIZE | 0.035 | 3/64 | 0.035 | 3/64 |
| MATERIAL THICKNESS WFS / ARC CONTROL | 14 ga. | 250 / 0 | 200 / 0 | 230 / 0 |
| | 10 ga. | 400 / 0 | 280 / 0 | 425 / 0 |
| | 3/16 | 550 / 0 | 340 / 0 | 670 / 0 |
| | 1/4 | 600 / 0 | 400 / 0 | 700 / 0 |
| COMMENTS | Not Recommended below 200 WFS | Not Recommended below 100 WFS | Not Recommended below 200 WFS | Not Recommended below 200 WFS |

V350-PRO



V350-PRO



TABLE OF CONTENTS - ACCESSORIES SECTION -

Accessories.....Section C

Cobramatic & Tig Module Connection Instructions.....C-2

Options/Accessories.....C-2

Quick Disconnect PlugsC-3

Connection of Lincoln Electric Wire Feeders.....C-4 Thru C-11

 V350-PRO/LN-25 with Optional 6 Pin K441-1 Remote.....C-4

 V350-PRO/LN-25 with Optional 6 Pin K857 RemoteC-5

 LN-25 with K431 Remote Option.....C-6

 V350-PRO/LN-25 with K867 AdapterC-7

 V350-PRO/LN-7 with K480 Control CableC-8

 V350-PRO/LN-7 with K867 AdapterC-9

 V350-PRO/LN-742C-10

 V350-PRO/LN-10 with K1505 Control CableC-11

V350-PRO



ACCESSORIES

Cobramatic Connection Instructions

A Cobramatic can only be used with a Factory or "CE" version of the V350

1. Turn the Invertec power switch "off"
2. Connect the control cable from the Cobramatic to the 24/42 VAC 14-pin wire feeder amphenol on the rear of the Invertec.
3. Connect the electrode cable to the output terminal of the polarity required by electrode. Connect the work lead to the other terminal.
4. Set the meter polarity switch on the front of the Invertec to coincide with wire feeder polarity used.
5. If a remote control such as K857 is to be used with the Cobramatic, the remote can be connected directly to the 6pin amphenol on the front of the Invertec or use a K864 adapter to connect the cobramatic and the remote to the 24/42VAC 14-pin wire feeder amphenol connector on the rear of the Invertec.

TIG Module K930-2

The TIG Module connects to the V350-Pro Factory or CE versions with a K936-1 (9-14 pin) control cable. Connect the K936-1 to the 115VAC Wire Feeder Amphenol on the rear of the V350-Pro.

The TIG Module can also be used with the V350 Construction version. A K936-4 control cable is required to supply 115VAC to the TIG Module from an external 115VAC supply.

General Instructions for Connection of Wire Feeders to V350-Pro

Wire feeders other than LN-7 and LN-25 may be used provided that the auxiliary power supply capacity of the V350-Pro is not exceeded. K867 universal adapter plug is required. See connection diagram S19406 and S19386 at the back of this manual for more information.

Remote Control of Invertec

Remote Control K857, Hand Amptrol K963 and Foot Amptrol K870.

OPTIONS / ACCESSORIES

Construction Version – K1728-2

- All welding modes for this model run with local output control and weld terminals ON (e.g. Stick, TIG, LN25 off the arc).

| | |
|------------------|--------------------|
| K930-1 | TIG Module |
| K428, K446, K449 | LN-25(Off the Arc) |

"CE" Version – K1728-3

- The "CE" version is the Factory version with the addition of power line filtering allowing the machine to comply with the European and Australian EMC emission requirements.

Field Installed Options/Accessories

Two versions of the V350-Pro are available from the factory for both the CE and ROW versions. Options for K1728-1 Factory and K1728-3 "CE" V350's

- TIG Gas Control Kit – K1762-2
- Advanced Process Panel – K1763-1

Options for all models of V350-PRO

- Undercarriage – K1764-1
- Valet Style Undercarriage - K1838-1

Welding Cable Connectors:

- K852-70 1/0-2/0 cable
- K852-95 2/0-3/0 cable

FACTORY VERSION and ADVANCED PROCESS VERSION

| | |
|------|-----------------------|
| K857 | Remote Output Control |
| K814 | Arc Start Switch |
| K812 | Hand Operated Amptrol |
| K870 | Foot Operated Amptrol |

Note: All of the above remote controls connect directly to the 6-pin MS-style connector, with either a K864 or K876 adapter and connect it to the 14 pin wire feeder MS-style connector. (See Diagram in Section F-1)

| | |
|---------------------------------|------------|
| K930-[] | TIG Module |
| K428, K446, K449 | LN-25 * |
| K617 (-1 or -2) K618 (-1 or -2) | LN-742 |
| K440 (-1), K567-1 | LN-7 GMA |
| K1559-1, K1564-1 | LN-10 |
| K1499-1, K1521-1 | DH-10 |
| K1587-1 | Cobramatic |

*Not recommended for pulse welding

V350-PRO



QUICK DISCONNECT PLUGS

A quick disconnect system is used for the welding cable connections. The K852-70 is designed to accept a welding cable size of 1/0 to 2/0.

1. Remove 25mm (1 in.) of welding cable insulation.
2. Slide rubber boot onto cable end. The boot end may be trimmed to match the cable diameter. Soap or other lubricant will help to slide the boot over the cable.

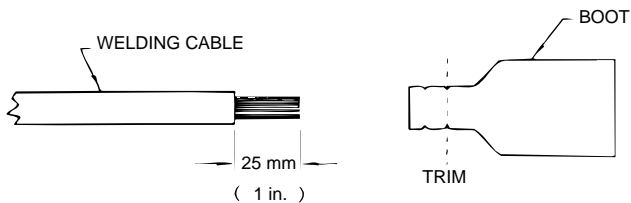

3. Slide the copper tube into the brass plug.
4. Insert cable into copper tube.

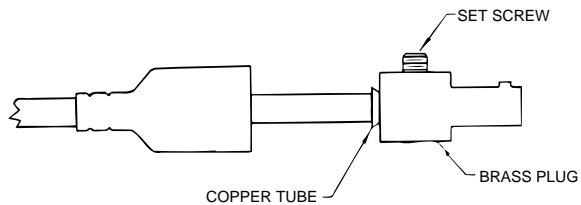

5. Tighten set screw to collapse copper tube. Screw must apply pressure against welding cable. The top of the set screw will be well below the surface of the brass plug after tightening.
6. Slide rubber boot over brass plug. The rubber boot must be positioned to completely cover all electrical surfaces after the plug is locked into the receptacle.

V350-PRO

LINCOLN[®]
ELECTRIC

CONNECTION OF LINCOLN ELECTRIC WIRE FEEDERS

CONNECTION OF THE LN-25 TO THE V350-PRO "ACROSS THE ARC" WITH OPTIONAL 6 PIN K441-1 REMOTE CONTROL.

1. Remove input power to the V350-PRO.
2. Connect the electrode cable to the output terminal of polarity required by the electrode. Connect the work lead to the other terminal. Welding cable must be sized for current and duty cycle of the application.
3. Attach the single lead from the LN-25 control box to the work using the spring clip on the end of the lead. This is only a control lead - it carries no welding current.

4. Set the voltmeter switch to the electrode polarity chosen.
5. Set "CONTROL SELECT" to "REMOTE".
6. Set the "MODE" to the "CV-WIRE" position.
7. Set "WELD TERMINALS SELECT" to the "ON"

⚠ CAUTION

position.

If you are using an LN-25 without an internal contactor, the electrode will be "HOT" when the V350-PRO is energized.

8. Set the "ARC CONTROL" to the "O" position and then adjust to suit.

Figure C.1 V350-PRO/LN-25 ACROSS THE ARC CONNECTION DIAGRAM

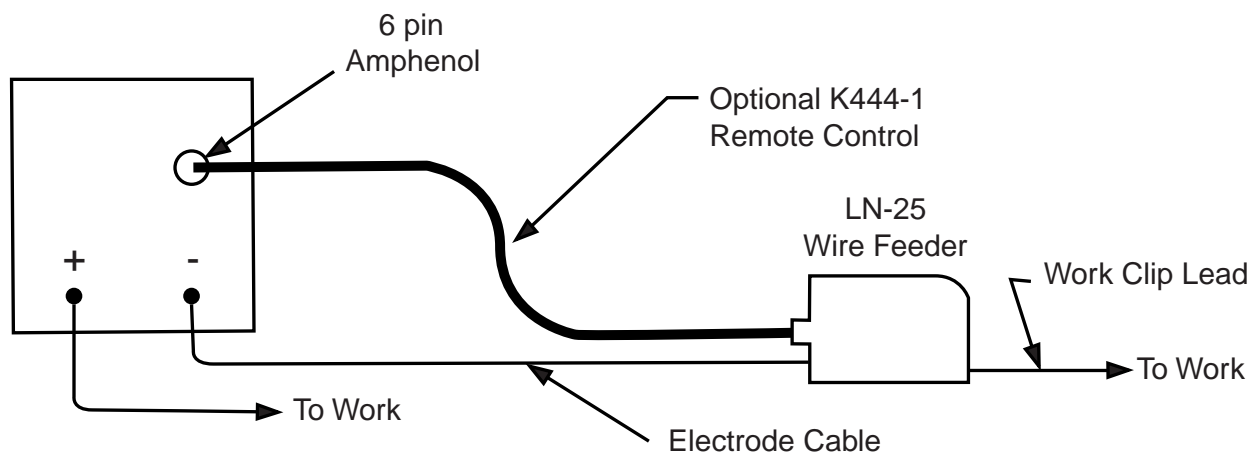

NOTE: Illustration shows electrode connected for negative polarity.

V350-PRO

LINCOLN[®]
ELECTRIC

CONNECTION OF THE LN-25 TO THE V350-PRO "ACROSS THE ARC" WITH OPTIONAL 6 PIN K857 REMOTE CONTROL.

1. Remove input power to the V350-PRO.
2. Connect the electrode cable to the output terminal of polarity required by the electrode. Connect the work lead to the other terminal. Welding cable must be sized for current and duty cycle of the application.
3. Connect the K857 remote control to the 6-pin amphenol on the V350-PRO.
4. Attach the single lead from the LN-25 control box to the work using the spring clip on the end of the lead. This is only a control lead - it carries no welding current.
5. Set the voltmeter switch to the electrode polarity chosen.
6. Set "CONTROL SELECT" to "REMOTE".
7. Set the "MODE" to the "CV-WIRE" position.
8. Set "WELD TERMINALS SELECT" to the "ON" position.
9. Set the "ARC CONTROL" to the "O" position and then adjust to suit.

⚠ CAUTION

If you are using an LN-25 without an internal contactor, the electrode will be "HOT" when the V350-PRO is energized.

Figure C.2 V350-PRO/LN-25 ACROSS THE ARC CONNECTION DIAGRAM WITH K857 REMOTE CONTROL

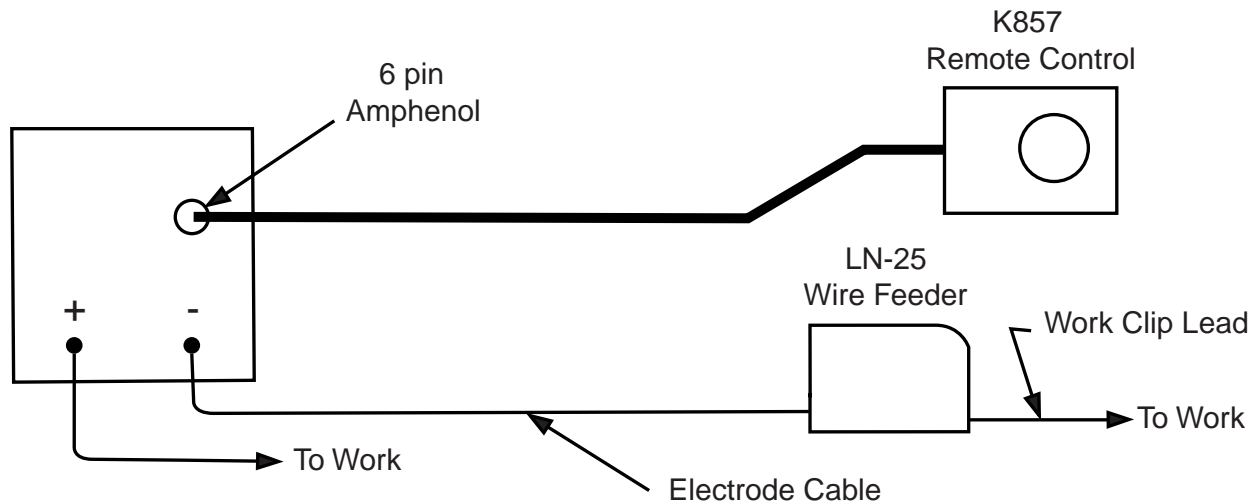

NOTE: Illustration shows electrode connected for negative polarity.

V350-PRO

LINCOLN[®]
ELECTRIC

ACCESSORIES

CONNECTION OF THE LN-25 WITH K431 REMOTE OPTION TO THE V350-PRO.

NOTE: AN LN-25 CAN ONLY BE USED WITH A FACTORY OR "CE" VERSION OF THE V350-PRO.

1. Remove input power to the V350-PRO.
2. Connect the electrode cable to the output terminal of polarity required by the electrode. Connect the work lead to the other terminal. Welding cable must be sized for current and duty cycle of the application.
3. Attach the single lead from the LN-25 control box to the work using the spring clip on the end of the lead. This is only a control lead - it carries no welding current.
4. Set the voltmeter switch to the electrode polarity chosen.
5. Set "CONTROL SELECT" to "REMOTE".
6. Set the "MODE" to the "CV-WIRE" position.
7. Set "WELD TERMINALS SELECT" to the "REMOTE" position.
8. Set the "ARC CONTROL" to the "O" position and then adjust to suit.
9. Connect the K432 remote control cable to the LN-25.
10. Connect the K876 adapter to the K432 and to the 24/42VAC 14-pin amphenol located at the rear of the V350-PRO.
11. Adjust the wire feed speed and voltage at the LN-25.

NOTE: See **Figure C.4** for connection Using K867 adapter.

Figure C.3 LN-25 with K431 Remote Option to the V350-PRO

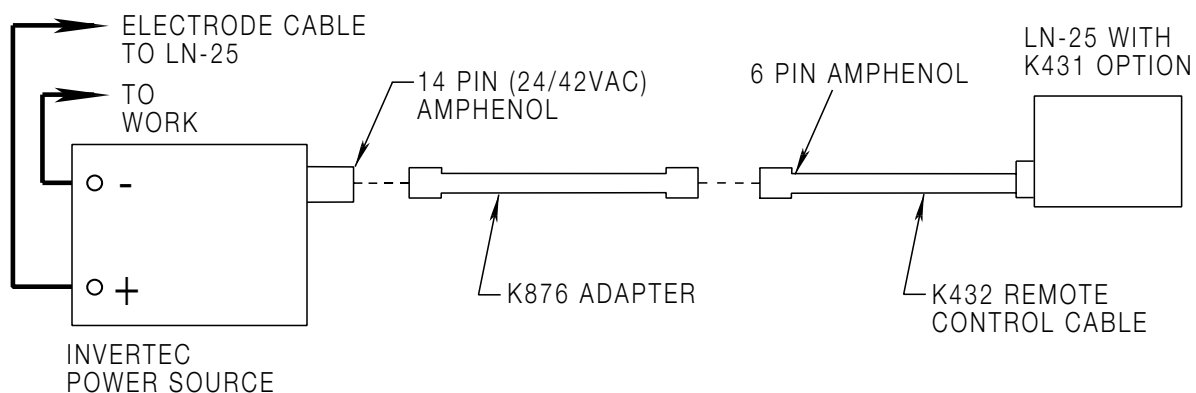

NOTE: Illustration shows electrode connected for positive polarity.

V350-PRO



ACCESSORIES

CONNECTION OF THE K867 ADAPTER FOR USE WITH LN-25 WITH K431 OPTION/V350-PRO.

1. Insulate each unused lead individually.
2. Remove 6 pin plug from K432 cable in order to connect K867 adapter.
3. Label each lead (A thru F) as they are removed from the 6 pin plug.
4. Splice leads and insulate.

Figure C.4 Connection of LN-25 to V350-PRO using K867 adapter.

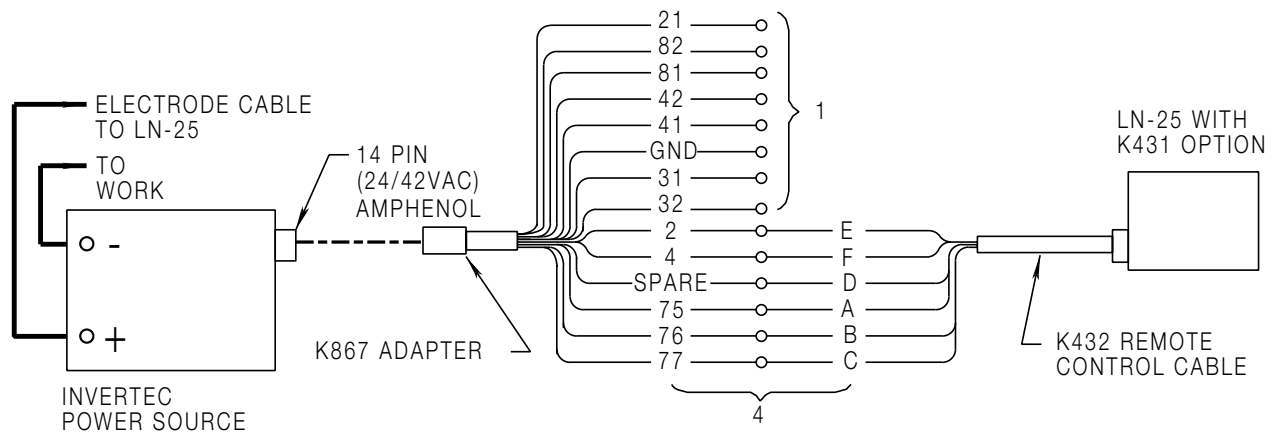

V350-PRO



ACCESSORIES

CONNECTION OF THE LN-7 TO THE V350-PRO USING K480 CONTROL CABLE (SEE FIGURE C.5)

NOTE: AN LN-7 CAN ONLY BE USED WITH A FACTORY OR "CE" VERSION OF THE V350-PRO. IF YOUR LN-7 COMES EQUIPPED WITH A K291 OR K404 INPUT CABLE, REFER TO THE CONNECTION OF THE LN-7 USING K867 UNIVERSAL ADAPTER.

1. Remove input power to the V350-PRO.
2. Connect the electrode cable from the K480 control cable to the "+" terminal of the welder and to the LN-7 wire feeder. Connect the work cable to the "-" terminal of the welder.

NOTE: Figure C.5 shows the electrode connected for positive polarity. To change polarity, shut the welder off and reverse the electrode and work cables at the output terminals.

NOTE: Welding cable must be sized for current and duty cycle of application.

3. Connect the input cable from the K480 control cable to the (115VAC) 14 pin amphenol on the V350-PRO and the input cable plug on the LN-7.
4. Set the "VOLTMETER" switch to "+" or "-" depending on the polarity chosen.
5. Set "CONTROL SELECT" to "REMOTE".
6. Set the "MODE" to the "CV-WIRE" position.
7. Place the "WELD TERMINALS SELECT" in the "REMOTE" position.
8. Adjust wire feed speed at the LN-7 and adjust the welding voltage with the optional remote control if used.
9. Set the "ARC" control at "0" initially and adjust to suit.

Figure C.5 V350-PRO/LN-7 with K480 Control Cable Connection Diagram

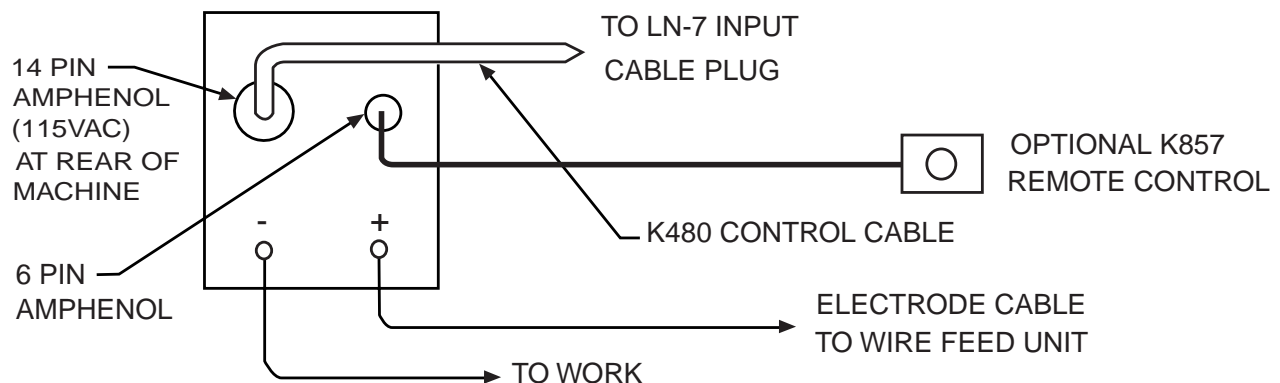

V350-PRO



CONNECTION OF THE K867 ADAPTER FOR USE WITH THE K291 OR K404 INPUT CABLES AND LN-7.

1. Insulate each unused lead individually.
2. Splice leads and insulate.

Figure C.6 Connection of LN-7 to V350-PRO using K867 adapter.

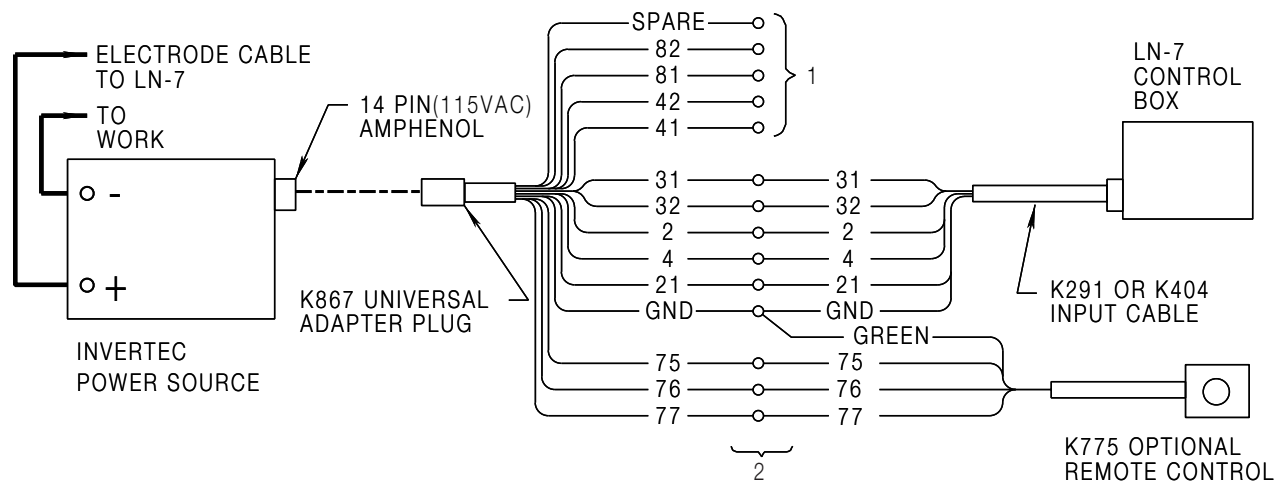

V350-PRO

LINCOLN[®]
ELECTRIC

ACCESSORIES

CONNECTION OF THE LN-742 TO THE V350-PRO (SEE FIGURE C.7)

NOTE: AN LN-7 CAN ONLY BE USED WITH A FACTORY OR "CE" VERSION OF THE V350-PRO.

1. Remove input power to the V350-PRO.
2. Connect the electrode cable from the LN-742 to the "+" terminal of the welder. Connect the work cable to the "-" terminal of the welder.

NOTE: Figure C.7 shows the electrode connected for positive polarity. To change polarity, shut the welder off and reverse the electrode and work cables at the output terminals.

NOTE: Welding cable must be sized for current and duty cycle of application.

3. Connect the K591 control cable to the 24/42VAC 14 pin amphenol on the back of the V350-PRO and the input cable plug on the LN-742.
4. Set the "VOLTMETER" switch to "+" or "-" depending on the polarity chosen.
5. Set the "MODE" to the "CV-WIRE" position..
6. Set "CONTROL SELECT" to "LOCAL".
7. Place the "WELD TERMINALS SELECT" in the "REMOTE" position.
8. Adjust wire feed speed at the LN-742.
9. Set the "ARC" control at "0" initially and adjust to suit.

Figure C.7 V350-PRO/LN-742 Connection Diagram

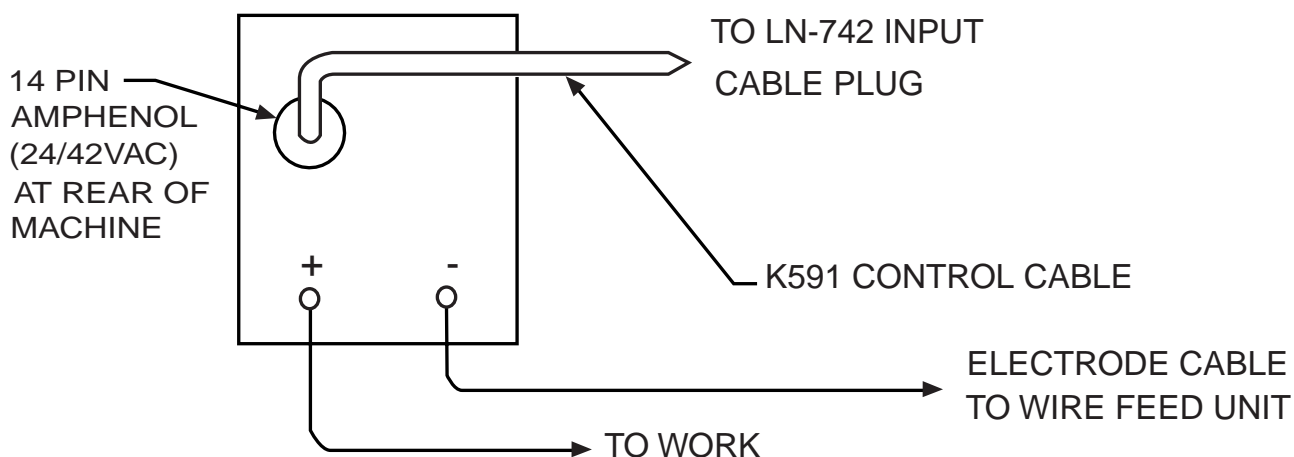

V350-PRO



ACCESSORIES

CONNECTION OF THE LN-10 TO THE V350-PRO USING THE K1505 CONTROL CABLE.

NOTE: AN LN-10 CAN ONLY BE USED WITH A FACTORY OR "CE" VERSION OF THE V350-PRO.

1. Remove input power to the V350-PRO.
2. Connect the K1505 control cable from the LN-10 to the Invertec 24/42VAC 14 pin amphenol connector on the rear of the V350-PRO.
3. Connect the electrode cable to the output terminal of polarity required by the electrode. Connect the work lead to the other terminal.
4. Set the meter polarity switch on the front of the V350-PRO to coincide with wire feeder polarity used.
5. Set "CONTROL SELECT" to "REMOTE".
6. Set the "MODE" to the "CV-WIRE" position..
7. Set the "WELD TERMINALS SELECT" to the "REMOTE" position.
8. Set the "ARC CONTROL" to the "0" position and then adjust to suit.
9. Set wire feed speed and voltage at the LN-10.
NOTE: The voltage set point displayed on the V350-PRO should be ignored when operating in the remote control mode with the LN-10.
10. See the LN-10 manual for details on accessing the control DIP switch.
11. The control DIP switch inside the LN-10 should be set per the instructions in the LN-10 manual.

Figure C.8 LN-10 V350-PRO

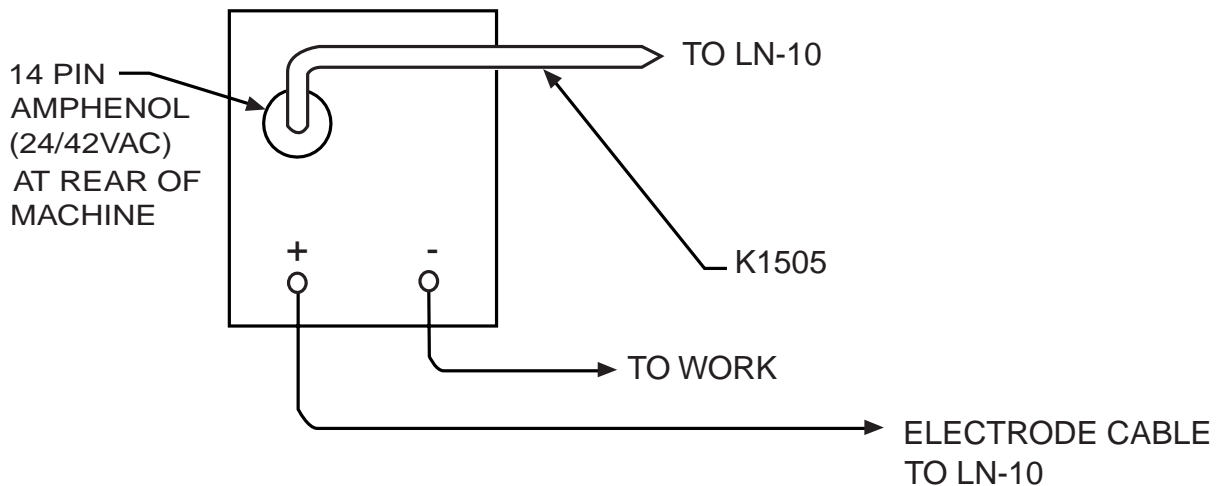

V350-PRO

LINCOLN[®]
ELECTRIC

V350-PRO



TABLE OF CONTENTS

-MAINTENANCE-

| | |
|-------------------------------------|------------------|
| Maintenance | Section D |
| Capacitor Discharge Procedure | D-2 |
| Visual Inspection..... | D-2 |
| Routine Maintenance..... | D-2 |
| Periodic Maintenance..... | D-2 |
| Major Component Locations | D-3 |

V350-PRO



MAINTENANCE

⚠ WARNING

Have qualified personnel do the maintenance work. Always use the greatest care when working near moving parts.

Do not put your hands near the cooling blower fan. If a problem cannot be corrected by following the instructions, take the machine to the nearest Lincoln Field Service Shop.



ELECTRIC SHOCK can kill.

- Do not touch electrically live parts or electrode with skin or wet clothing.
- Insulate yourself from work and ground
- Always wear dry insulating gloves.

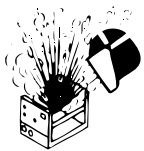

EXPLODING PARTS can cause injury.

- Failed parts can explode or cause other parts to explode when power is applied.
- Always wear a face shield and long sleeves when servicing.

See additional warning information throughout this Operator's Manual.

CAPACITOR DISCHARGE PROCEDURE

1. Obtain a power resistor (25 ohms, 25 watts).
2. Hold resistor body with electrically insulated glove. DO NOT TOUCH TERMINALS. Connect the resistor terminals across the two studs in the position shown. Hold in each position for 1 second. Repeat for all four capacitors.

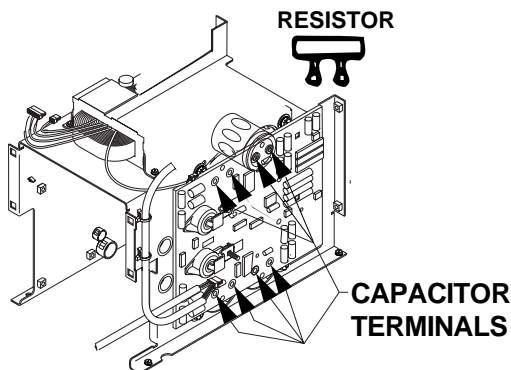

3. Use a DC voltmeter to check that voltage is not present across the terminals on all four capacitors.

VISUAL INSPECTION

Clean interior of machine with a low pressure air stream. Make a thorough inspection of all components. Look for signs of overheating, broken leads or other obvious problems. Many problems can be uncovered with a good visual inspection.

ROUTINE MAINTENANCE

1. Every 6 months or so the machine should be cleaned with a low pressure airstream. Keeping the machine clean will result in cooler operation and higher reliability. Be sure to clean these areas:
 - All printed circuit boards
 - Power switch
 - Main transformer
 - Input rectifier
 - Auxiliary Transformer
 - Reconnect Switch Area
 - Fan (Blow air through the rear louvers)
2. Examine the sheet metal case for dents or breakage. Repair the case as required. Keep the case in good condition to insure that high voltage parts are protected and correct spacings are maintained. All external sheet metal screws must be in place to insure case strength and electrical ground continuity.

PERIODIC MAINTENANCE

Overload Protection

The machine is electrically protected from producing high output currents. Should the output current exceed 430A, an electronic protection circuit will reduce the current to approximately 100A. The machine will continue to produce this low current until the protection circuit is reset. Reset occurs when the output load is removed.

Thermal Protection

Thermostats protect the machine from excessive operating temperatures. Excessive temperatures may be caused by a lack of cooling air or operating the machine beyond the duty cycle and output rating. If excessive operating temperature should occur, the thermostat will prevent output voltage or current. The meter will remain energized during this time.

Thermostats are self-resetting once the machine cools sufficiently. If the thermostat shutdown was caused by excessive output or duty cycle and the fan is operating normally, the Power Switch may be left on and the reset should occur within a 15 minute period.

V350-PRO



MAINTENANCE

FIGURE D.1 – MAJOR COMPONENT LOCATIONS

1. Center Panel
2. Base Assembly
3. Case Back
4. Case Front
5. Case Wraparound

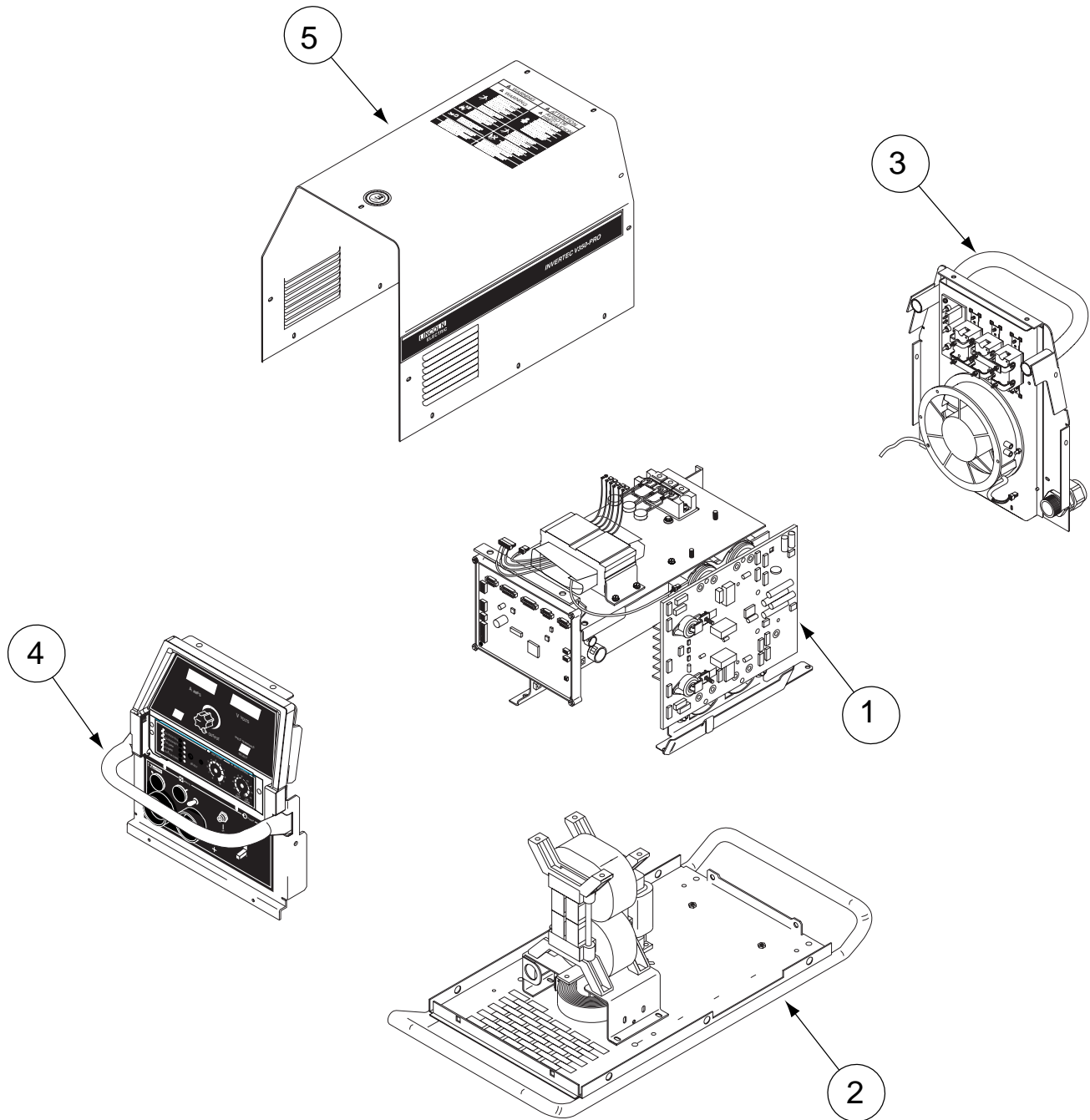

V350-PRO

LINCOLN[®]
ELECTRIC

V350-PRO



TABLE OF CONTENTS -THEORY OF OPERATION SECTION-

| | |
|--------------------------------------------------------------|------------------|
| Theory of Operation | Section E |
| General Description | E-2 |
| Input Line Voltage, Auxiliary Transformer and Precharge..... | E-2 |
| Switch Board and Main Transformer | E-3 |
| Power board, Control Board, and SPI Communications..... | E-4 |
| Output Rectifier and Choke | E-5 |
| Thermal Protection | E-6 |
| Protection Circuits | E-6 |
| Over current Protection | E-6 |
| Under/Over Voltage Protection | E-6 |
| Insulated Gate Bipolar Transistor (IGBT) Operation | E-7 |
| Pulse Width Modulation..... | E-8 |
| Minimum/Maximum Output..... | E-8 |

FIGURE E.1 – V350-PRO BLOCK LOGIC DIAGRAM

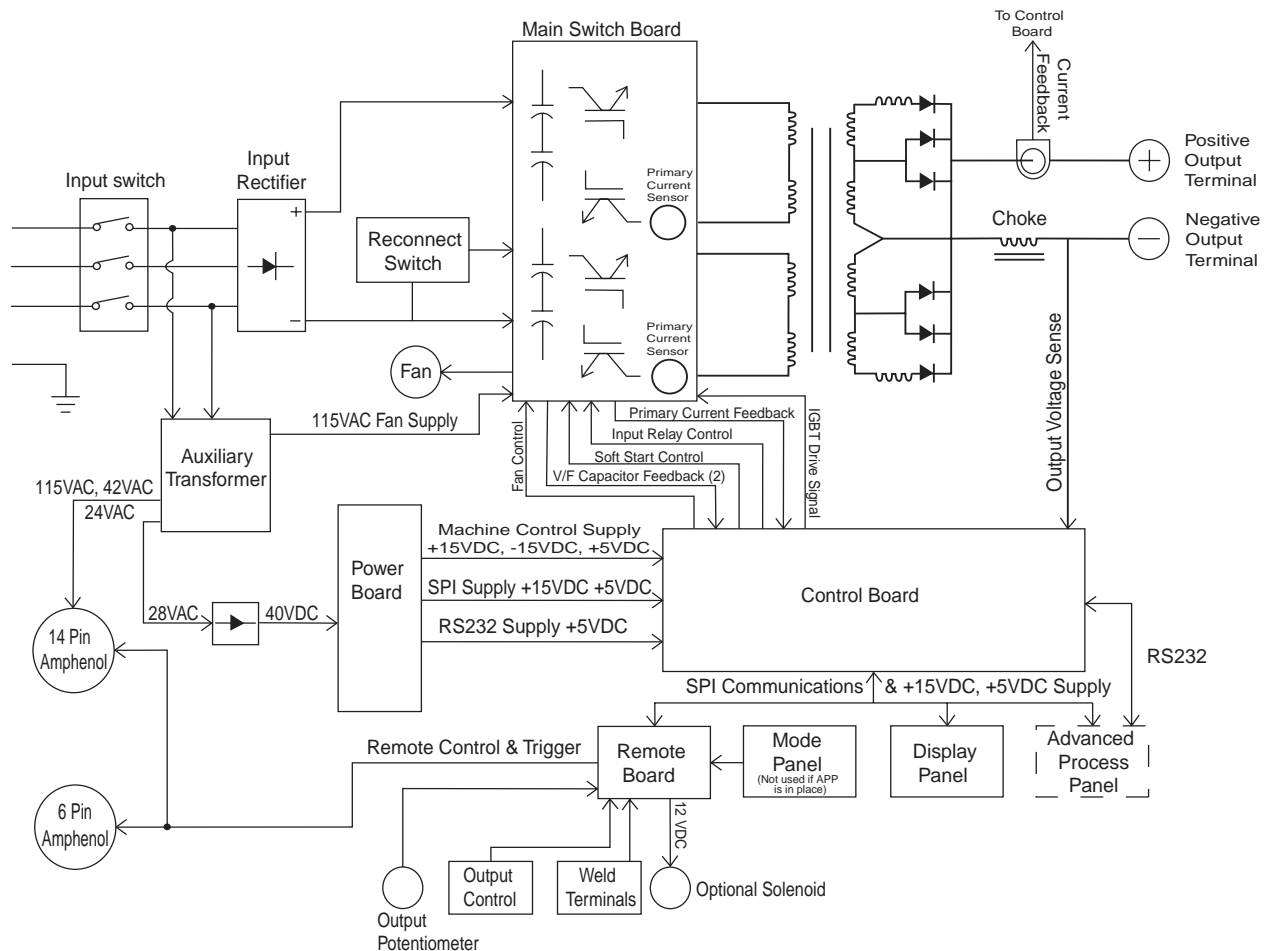

V350-PRO



THEORY OF OPERATION

FIGURE E.2 – INPUT VOLTAGE AND PRECHARGE

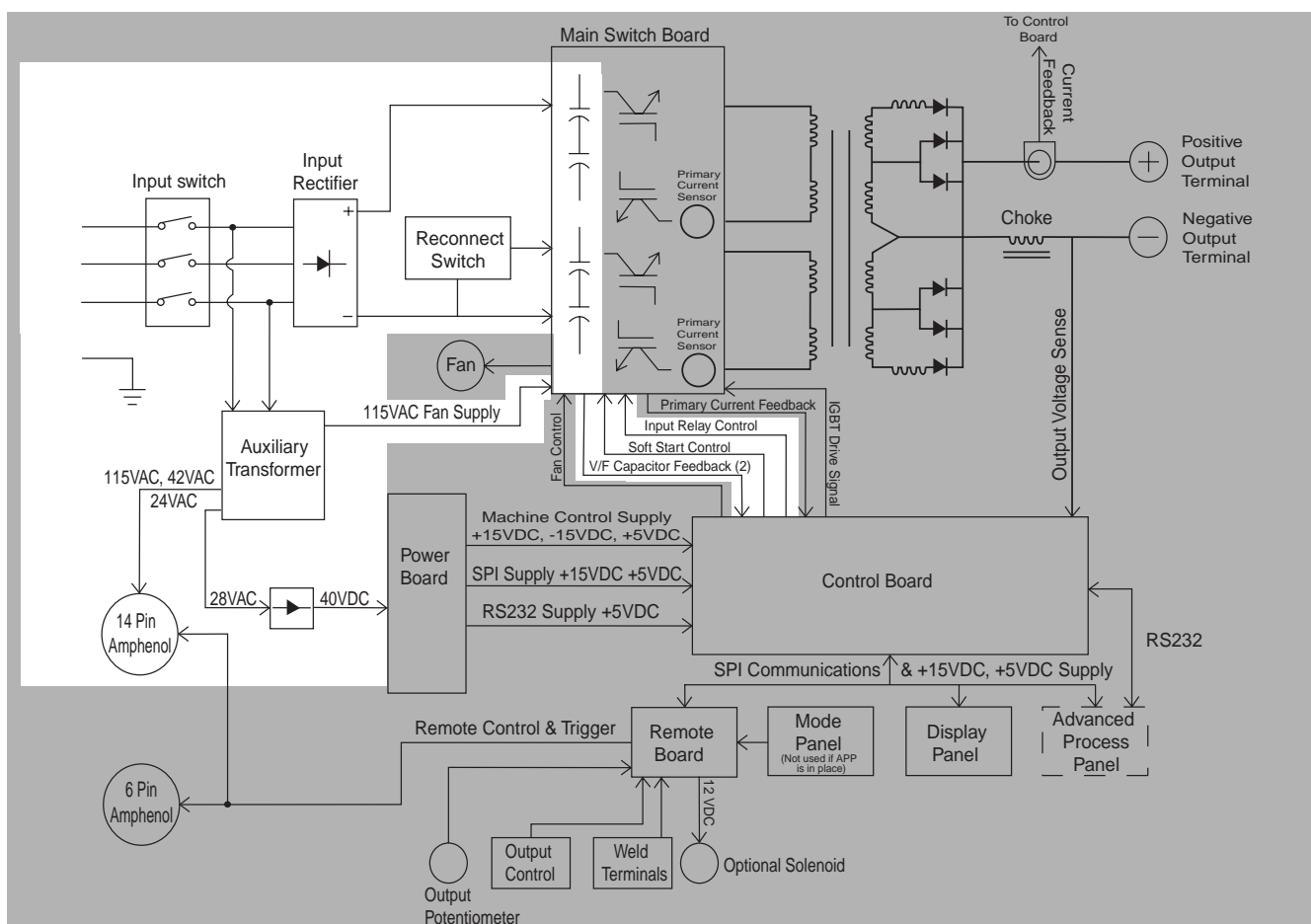

GENERAL DESCRIPTION

The Invertec V350-Pro is an inverter based welding power source that offers multi mode constant voltage (CV) and constant current (CC) welding and is rated at 350 amps 34VDC at a 60% duty cycle. The Invertec V350-Pro is available in a construction version (no wire feeder connection or auxiliary power), a factory version that includes a wire feeder connection and related power, an advanced process version and a rack version.

INPUT LINE VOLTAGE, AUXILIARY TRANSFORMER, & PRECHARGE

The Invertec V350-Pro can be connected for a variety of three-phase or single-phase input voltages. The initial power is applied to the V350 through a line switch located on the front of the machine. Two phases of the input voltage are applied to the auxiliary transformer. The auxiliary transformer develops four different secondary voltages. The 115VAC is used to power the fan motor and also is applied to the 14 pin amphenol type connector for wirefeeder operation. The 24VAC and 42VAC voltages are also applied to the 14 pin amphenol type connector to power wirefeeders. The 28VAC

is rectified and the resultant 40VDC is applied to the power board.

The input voltage is rectified by the input rectifier and the resultant DC voltage is applied to the switch board through the reconnect switch assembly located at the rear of the machine. The reconnect switch connect the two pairs of input capacitors either in a parallel (lower voltage) or series (higher voltage) configuration to accommodate the applied input voltage.

During the precharge time the DC input voltage is applied to the input capacitors through a current limiting circuit. The input capacitors are charged slowly and current limited. A voltage to frequency converter circuit located on the switch board monitors the capacitor voltages. This signal is coupled to the control board (measure frequency, not voltage to check signal). When the input capacitors have charged to an acceptable level, the control board energizes the input relays, that are located on the switch board, making all of the input power, without current limiting, available to the input capacitors. If the capacitors become under or over voltage the control board will de-energize the input relays and the V350 output will be disabled. Other possible faults may also cause the input relays to drop out.

NOTE: Unshaded areas of Block Logic Diagram are the subject of discussion.

V350-PRO

LINCOLN
ELECTRIC

THEORY OF OPERATION

FIGURE E.3 – SWITCH BOARD & MAIN TRANSFORMER

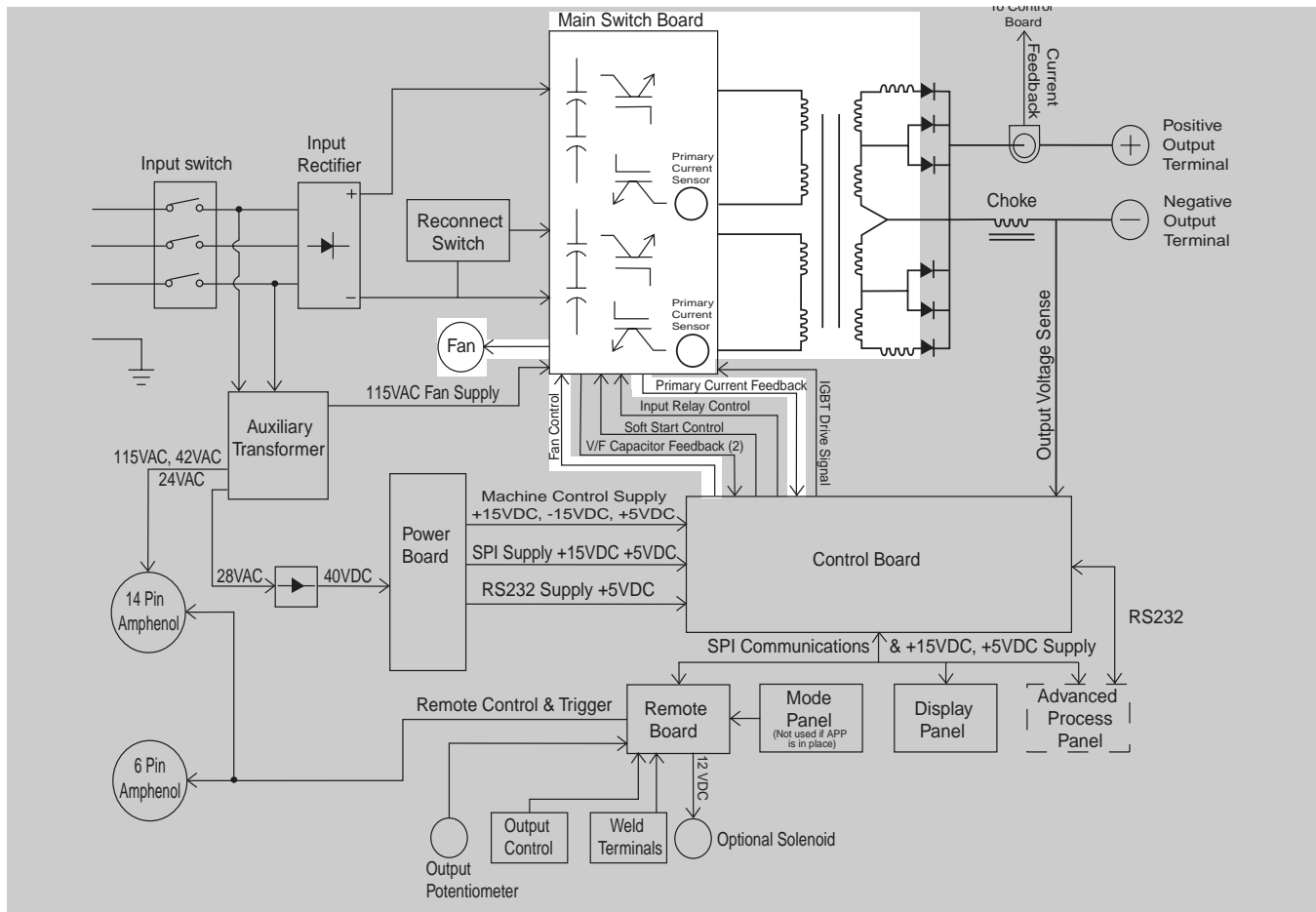

SWITCH BOARD & MAIN TRANSFORMER

There is one switch board in the Invertec V350-Pro. This board incorporates two pairs of input capacitors, two insulated gate bipolar transistor (IGBT) switching circuits, a fan motor drive circuit, and a voltage/frequency capacitor feedback circuit. The two capacitors in a pair are always in series with each other. When the reconnect switch is in the lower voltage position the capacitor pairs are in parallel. Thus two series capacitors in parallel with two series capacitors. When the reconnect switch is in the high voltage position the two capacitor pairs are in series. Thus four capacitors in series. This is required to accommodate the higher input voltages.

When the input capacitors are fully charged they act as power supplies for the IGBT switching circuits. When welding output is required the Insulated Gate Bipolar Transistors switch the DC power from the input capacitors, "on and off" thus supplying a pulsed DC current to the main transformer primary windings. **See IGBT Operation Discussion and Diagrams** in this section. Each IGBT switching circuit feeds current to a separate, oppositely wound primary winding in the

main transformer. The reverse directions of current flow through the main transformer primaries and the offset timing of the IGBT switching circuits induce an AC square wave output signal at the secondary of the main transformer. The two current transformers (CT) located on the switch board monitor these primary currents. If the primary currents become abnormally high the control board will shut off the IGBTs, thus disabling the machine output. The DC current flow through each primary winding is clamped back to each respective input capacitor when the IGBTs are turned off. This is needed due to the inductance of the transformer primary winding. The firing of the two switch boards occurs during halves of a 50 microsecond interval, creating a constant 20 KHZ output. In some low open circuit Tig modes the firing frequency is reduced to 5KHZ.

The Invertec V350-Pro has a F.A.N. fan as needed circuit. The fan operates when the welding output terminals are energized or when a thermal over temperature condition exists. Once the fan is activated it will remain on for a minimum of five minutes. The fan driver circuit is housed on the switch board but it is activated from a control board signal.

NOTE: Unshaded areas of Block Logic Diagram are the subject of discussion.

V350-PRO

LINCOLN
ELECTRIC

THEORY OF OPERATION

FIGURE E.4 – POWER BOARD, CONTROL BOARD AND SERIAL PERIPHERAL INTERFACE (SPI) COMMUNICATIONS

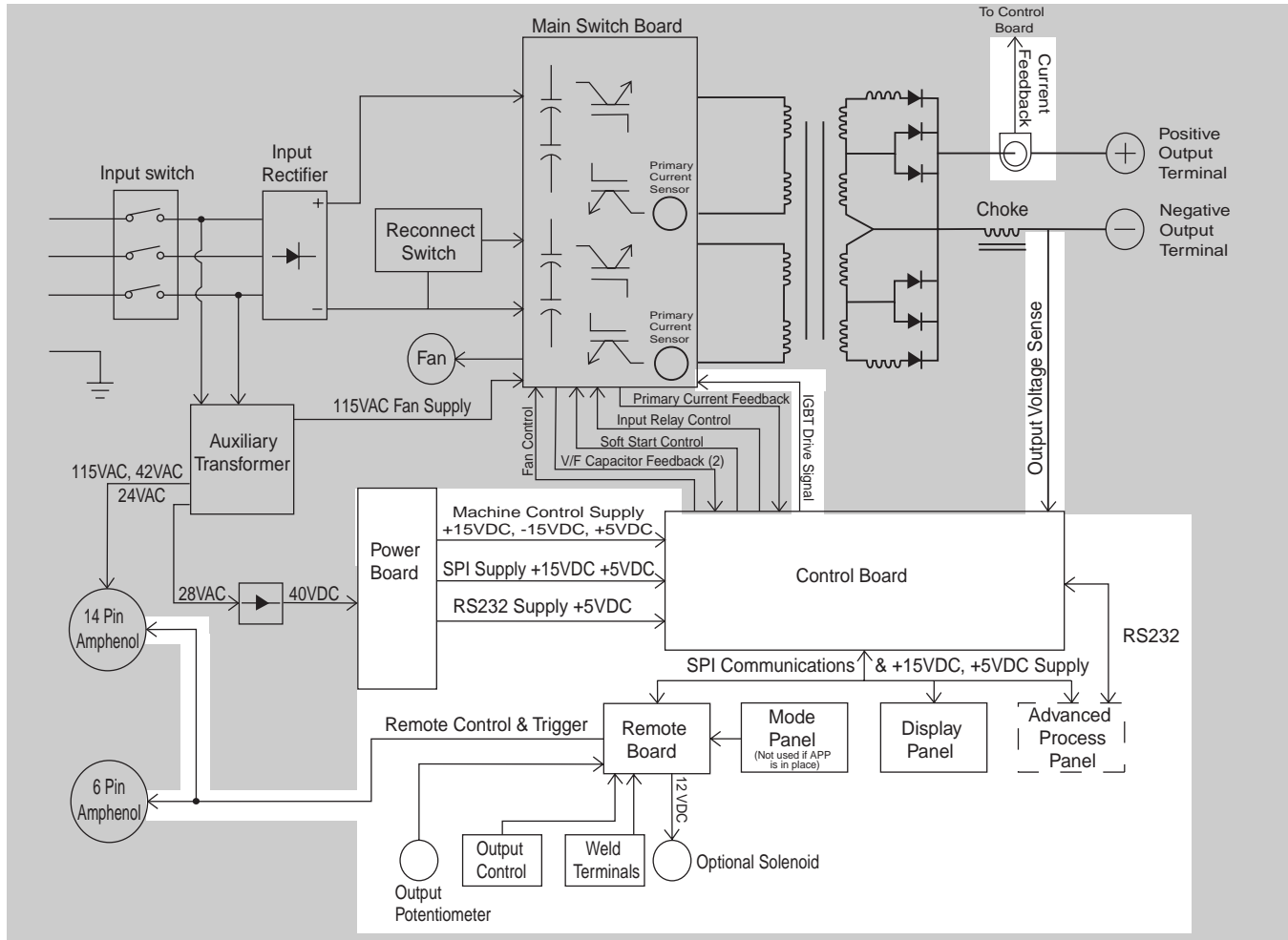

POWER BOARD, CONTROL BOARD AND SERIAL PERIPHERAL INTERFACE (SPI) COMMUNICATIONS

POWER BOARD

The 28VAC auxiliary is rectified and filtered and applied to the power board. The power board, utilizing a switching power supply, processes the 40VDC input and develops several regulated positive and negative DC supplies. Three DC supplies are fed to the control board for machine control supplies. Two positive DC voltages are coupled to the control board for the Serial Peripheral Communications (SPI) supplies. A +5VDC is used for the RS232 connection supply. An over or under input voltage detection and shutdown circuit is also part of the power board's circuitry. The optional 12VDC gas solenoid is powered by the remote board.

CONTROL BOARD

The control board performs the primary interfacing functions to establish and maintain output control of

the V350 machine. The control board sends and receives command signals from the mode or advanced process panel, the display panel and the remote panel. These communications are processed through a digital network called a Serial Peripheral Interface (SPI). This network digitally communicates to and from the control board the user's commands and various machine status messages. The software that is contained within the control board processes and compares these commands with the voltage and current feedback information it receives from the output current sensor and the output voltage sensing leads. The appropriate pulse width modulation (PWM) signals (**See Pulse Width Modulation** in this section) are sent to the switch board IGBTs. In this manner, the digitally controlled high-speed welding waveform is created and regulated.

The control board also monitors the thermostats, the main transformer primary currents and the input capacitor voltages.

NOTE: Unshaded areas of Block Logic Diagram are the subject of discussion.

V350-PRO

LINCOLN
ELECTRIC

THEORY OF OPERATION

FIGURE E.5 – OUTPUT RECTIFIER AND CHOKE

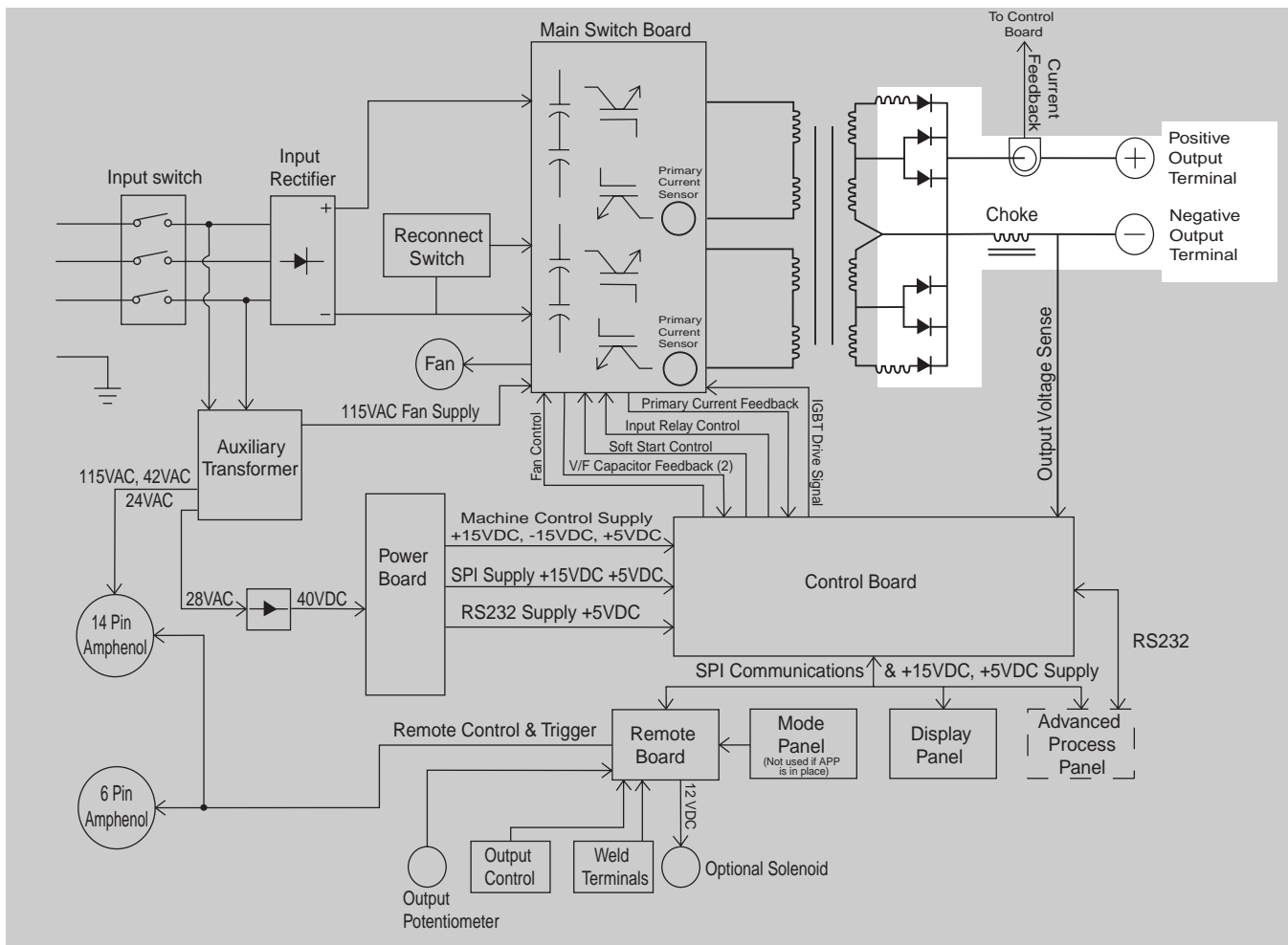

OUTPUT RECTIFIER AND CHOKE

The output rectifier receives the AC output from the main transformer secondary and rectifies it to a DC voltage level. Since the output choke is in series with the negative leg of the output rectifier and also in series with the welding load, a filtered DC output is applied to the machine's output terminals.

NOTE: Unshaded areas of Block Logic Diagram are the subject of discussion.

THEORY OF OPERATION

THERMAL PROTECTION

Two normally closed (NC) thermostats protect the machine from excessive operating temperatures. These thermostats are wired in series and are connected to the control board. One of the thermostats is located on the heat sink of the switch board and the other is located on the output choke. Excessive temperatures may be caused by a lack of cooling air or operating the machine beyond its duty cycle or output rating. If excessive operating temperatures should occur, the thermostats will prevent output from the machine. The yellow thermal light, located on the front of the machine, will be illuminated. The thermostats are self-resetting once the machine cools sufficiently. If the thermostat shutdown was caused by excessive output or duty cycle and the fan is operating normally, the power switch may be left on and the reset should occur within a 15-minute period.

PROTECTIVE CIRCUITS

Protective circuits are designed into the V350-PRO to sense trouble and shut down the machine before damage occurs to the machine's internal components.

OVER CURRENT PROTECTION

If the average current exceeds 450 amps for one second, then the output will be limited to 100 amps until the load is removed. If the peak current exceeds 600 amps for 150 ms, the output will be limited to 100 amps until the load is removed.

UNDER/OVER VOLTAGE PROTECTION

Protective circuits are included on the switch and control boards to monitor the voltage across the input capacitors. In the event that a capacitor pair voltage is too high, or too low, the machine output will be disabled. The protection circuits will prevent output if any of the following conditions exist.

1. Voltage across a capacitor pair exceeds 467 volts. (High line surges or improper input voltage connections.)
2. Voltage across a capacitor pair is under 190 volts. (Due to improper input voltage connections.)
3. Internal component damage.

V350-PRO



INSULATED GATE BIPOLAR TRANSISTOR (IGBT) OPERATION

An IGBT is a type of transistor. IGBT are semiconductors well suited for high frequency switching and high current applications.

Example A in Figure E.6 shows an IGBT in passive mode. There is no gate signal, zero volts relative to the source, and therefore, no current flow. The drain terminal of the IGBT may be connected to a voltage supply; but since there is no conduction, the circuit will not supply current to components connected to the source. The circuit is turned OFF like a light switch.

Example B shows the IGBT in an active mode. When the gate signal, a positive DC voltage relative to the source, is applied to the gate terminal of the IGBT, it is

capable of conducting current. A voltage supply connected to the drain terminal will allow the IGBT to conduct and supply current to the circuit components coupled to the source. Current will flow through the conducting IGBT to downstream components as long as the positive gate signal is present. This is similar to turning ON a light switch.

FIGURE E.6 – IGBT

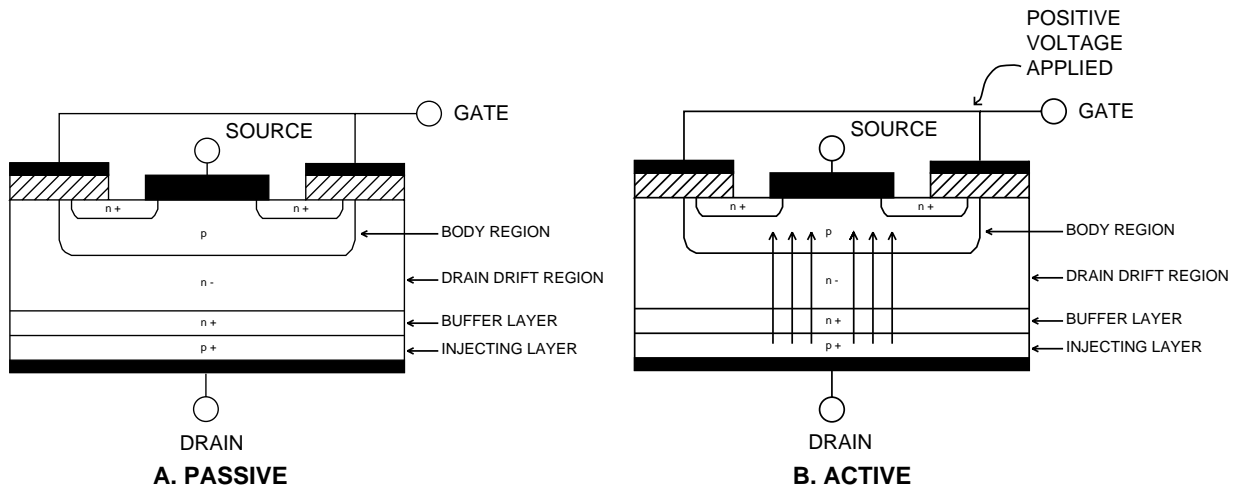

V350-PRO

LINCOLN[®]
ELECTRIC

THEORY OF OPERATION

FIGURE E.7 — TYPICAL IGBT OUTPUTS.

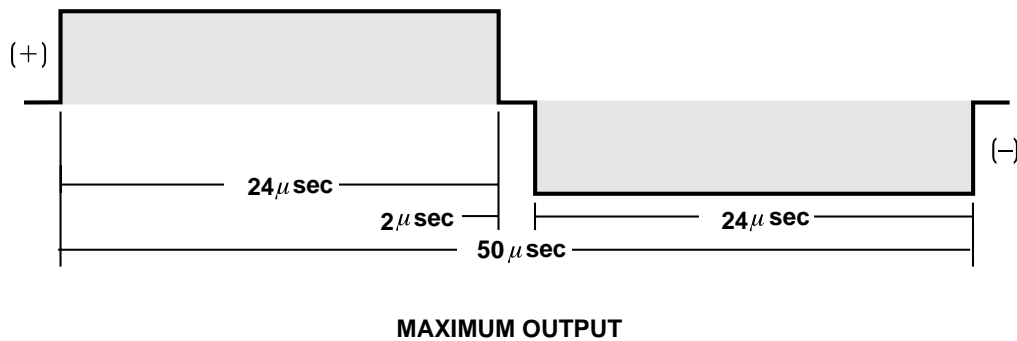
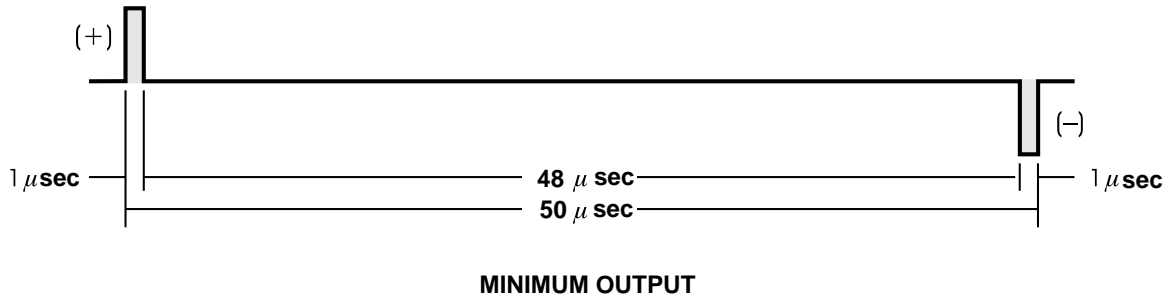

PULSE WIDTH MODULATION

The term Pulse Width Modulation is used to describe how much time is devoted to conduction in the positive and negative portions of the cycle. Changing the pulse width is known as modulation. Pulse Width Modulation (PWM) is the varying of the pulse width over the allowed range of a cycle to affect the output of the machine.

MINIMUM OUTPUT

By controlling the duration of the gate signal, the IGBT is turned on and off for different durations during the cycle. The top drawing in Figure E.7 shows the minimum output signal possible over a 50-microsecond time period.

The positive portion of the signal represents one IGBT group¹ conducting for one microsecond. The negative portion is the other IGBT group¹. The dwell time (off time) is 48 microseconds (both IGBT groups off). Since only two microseconds of the 50-microsecond time period is devoted to conducting, the output power is minimized.

MAXIMUM OUTPUT

By holding the gate signal on for 24 microseconds each, and allowing only two microseconds of dwell time (off time) during the 50-microsecond cycle, the output is maximized. The darkened area under the top curve can be compared to the area under the bottom curve. The more dark area that is under the curve indicates that more power is present.

¹An IGBT group consists of two IGBT modules feeding one transformer primary winding.

V350-PRO

LINCOLN[®]
ELECTRIC

TABLE OF CONTENTS

TROUBLESHOOTING & REPAIR SECTION

| | |
|-----------------------------------------------------------|------------------|
| Troubleshooting & Repair Section | Section F |
| How to Use Troubleshooting Guide | F-2 |
| PC Board Troubleshooting Procedures and Replacement | F-3 |
| Troubleshooting Guide | F-4 |
| Test Procedures | |
| Input Filter Capacitor Discharge Procedure | F-15 |
| Main Switch Board Test | F-17 |
| Input Rectifier Test | F-21 |
| Power Board Test | F-25 |
| Output Diode Modules Test | F-29 |
| Auxiliary Transformer Test | F-33 |
| Current Transducer Test | F-37 |
| Fan Control and Motor Test | F-41 |
| SPI Cable Resistance and Voltage Test | F-45 |
| Voltage and Current Calibration Procedure | F-47 |
| Replacement Procedures | |
| Control Board Removal and Replacement | F-51 |
| Display Board Removal and Replacement | F-55 |
| Main Switch Board Removal and Replacement | F-59 |
| Advanced Process Panel Removal and Replacement | F-63 |
| Remote Board Removal and Replacement | F-69 |
| Snubber Board Removal and Replacement | F-73 |
| Power Board Removal and Replacement | F-75 |
| Input Rectifier Removal and Replacement | F-79 |
| Output Rectifier Modules Removal and Replacement | F-83 |
| Current Transducer Removal and Replacement | F-87 |
| Retest after Repair | F-92 |

V350-PRO



TROUBLESHOOTING & REPAIR

HOW TO USE TROUBLESHOOTING GUIDE



CAUTION

Service and repair should be performed by only Lincoln Electric Factory Trained Personnel. Unauthorized repairs performed on this equipment may result in danger to the technician and machine operator and will invalidate your factory warranty. For your safety and to avoid Electrical Shock, please observe all safety notes and precautions detailed throughout this manual.

This Troubleshooting Guide is provided to help you locate and repair possible machine malfunctions. Simply follow the three-step procedure listed below.

Step 1. LOCATE PROBLEM (SYMPTOM). Look under the column labeled “PROBLEM (SYMPTOMS)”. This column describes possible symptoms that the machine may exhibit. Find the listing that best describes the symptom that the machine is exhibiting. Symptoms are grouped into three main categories: Output Problems, Function Problems, and LED Function Problems.

Step 2. PERFORM EXTERNAL TESTS. The second column, labeled “POSSIBLE AREAS OF MISADJUSTMENT(S)”, lists the obvious external possibilities that may contribute to the machine symptom. Perform these tests/checks in the order listed. In general, these tests can be conducted without removing the case wrap-around cover.

Step 3. PERFORM COMPONENT TESTS. The last column, labeled “Recommended Course of Action” lists the most likely components that may have failed in your machine. It also specifies the appropriate test procedure to verify that the subject component is either good or bad. If there are a number of possible components, check the components in the order listed to eliminate one possibility at a time until you locate the cause of your problem.

All of the referenced test procedures referred to in the Troubleshooting Guide are described in detail at the end of this chapter. Refer to the Troubleshooting and Repair Table of Contents to locate each specific Test Procedure. All of the referred to test points, components, terminal strips, etc., can be found on the referenced electrical wiring diagrams and schematics. Refer to the Electrical Diagrams Section Table of Contents to locate the appropriate diagram.



CAUTION

If for any reason you do not understand the test procedures or are unable to perform the test/repairs safely, contact the Lincoln Electric Service Department for electrical troubleshooting assistance before you proceed. Call 1-800-833-9353.(WELD)

V350-PRO



TROUBLESHOOTING & REPAIR

PC BOARD TROUBLESHOOTING PROCEDURES

⚠ WARNING



ELECTRIC SHOCK can kill.

- Have an electrician install and service this equipment. Turn the input power OFF at the fuse box before working on equipment. Do not touch electrically hot parts.

⚠ CAUTION

Sometimes machine failures appear to be due to PC board failures. These problems can sometimes be traced to poor electrical connections. To avoid problems when troubleshooting and replacing PC boards, please use the following procedure:

1. Determine to the best of your technical ability that the PC board is the most likely component causing the failure symptom.
2. Check for loose connections at the PC board to assure that the PC board is properly connected.
3. If the problem persists, replace the suspect PC board using standard practices to avoid static electrical damage and electrical shock. Read the warning inside the static resistant bag and perform the following procedures:

PC board can be damaged by static electricity.



- Remove your body's static charge before opening the static-shielding bag. Wear an anti-static wrist strap. For safety, use a 1 Meg ohm resistive cord connected to a grounded part of the equipment frame.

- If you don't have a wrist strap, touch an un-painted, grounded, part of the equipment frame. Keep touching the frame to prevent static build-up. Be sure not to touch any electrically live parts at the same time.

- Tools which come in contact with the PC board must be either conductive, anti-static or static-dissipative.

- Remove the PC board from the static-shielding bag and place it directly into the equipment. Don't set the PC board on or near paper, plastic or cloth which could have a static charge. If the PC board can't be installed immediately, put it back in the static-shielding bag.

- If the PC board uses protective shorting jumpers, don't remove them until installation is complete.

- If you return a PC board to The Lincoln Electric Company for credit, it must be in the static-shielding bag. This will prevent further damage and allow proper failure analysis.

4. Test the machine to determine if the failure symptom has been corrected by the replacement PC board.

NOTE: It is desirable to have a spare (known good) PC board available for PC board troubleshooting.

NOTE: Allow the machine to heat up so that all electrical components can reach their operating temperature.

5. Remove the replacement PC board and substitute it with the original PC board to recreate the original problem.
 - a. If the original problem does not reappear by substituting the original board, then the PC board was not the problem. Continue to look for bad connections in the control wiring harness, junction blocks, and terminal strips.
 - b. If the original problem is recreated by the substitution of the original board, then the PC board was the problem. Reinstall the replacement PC board and test the machine.
6. Always indicate that this procedure was followed when warranty reports are to be submitted.

NOTE: Following this procedure and writing on the warranty report, "INSTALLED AND SWITCHED PC BOARDS TO VERIFY PROBLEM," will help avoid denial of legitimate PC board warranty claims.

V350-PRO



TROUBLESHOOTING & REPAIR

Observe Safety Guidelines detailed in the beginning of this manual.

TROUBLESHOOTING GUIDE

| PROBLEMS (SYMPTOMS) | POSSIBLE AREAS OF MISADJUSTMENT(S) | RECOMMENDED COURSE OF ACTION |
|---------------------------------------------------------------------------------------|------------------------------------------------------------------------------------------------------------------------------------------------------------------------------------------------------------------------------------------------------------------------------------------------------------------------------------------------------------------------------------------------------------------------------------------------------------------------------------------------------------------------------------------------------------------------------------------------------------------------------------------------------------------------------------|-------------------------------------------------------------------------------------------------------------------------------------------------------------------------------------------------------------------------------------------------------------------------------------------------------------------------------------------------------------------------------------------------------------|
| OUTPUT PROBLEMS | | |
| Major physical or electrical damage is evident when the sheet metal cover is removed. | 1. Contact your local authorized Lincoln Electric Field Service Facility for technical assistance. | 1. Contact the Lincoln Electric Service Department, 1-800-833-9353(WELD). |
| The machine is dead—no output—no displays. | <ol style="list-style-type: none"> 1. Make sure the input line/breaker switch is in the ON position. 2. Check the 3.5 amp circuit breaker (CB3). Reset if tripped. 3. Check the main input line fuses. If open, replace. 4. Check the 3.5 amp circuit breaker (CB2). Reset if tripped. 5. Check the 6 amp circuit breaker (CB1). Reset if tripped. 6. Make sure the reconnect switch and jumper lead is configured correctly for the applied input voltage. 7. If the machine is being operated with single phase input voltage make sure the red lead is not connected. See the Installation Section. | <ol style="list-style-type: none"> 1. Perform the Auxiliary Transformer Test. 2. Perform the Power Board Test. 3. The control rectifier and or associated filter capacitor (C5) may be faulty. Check and replace as necessary. 4. Perform The SPI Cable Resistance and Voltage Test. 5. The Control Board may be faulty. |
| The main input fuses (or breaker) repeatedly fail. | <ol style="list-style-type: none"> 1. Make certain the fuses or breakers are sized properly. 2. Make sure the reconnect switch and jumper lead is configured correctly for the applied input voltage. 3. The welding procedure may be drawing too much input current or the duty cycle may be too high. Reduce the welding current and /or reduce the duty cycle. | <ol style="list-style-type: none"> 1. Check the reconnect switches and associated wiring. See the Wiring Diagram. 2. Perform the Input Rectifier Test. 3. Perform the Main Switch Board Test. 4. Perform the Output Diode Module Test. 5. The Input Filter Capacitors may be faulty. Check, and if any are faulty replace all four. |



CAUTION

If for any reason you do not understand the test procedures or are unable to perform the test/repairs safely, contact the Lincoln Electric Service Department for electrical troubleshooting assistance before you proceed. Call 1-800-833-9353(WELD).

V350-PRO



TROUBLESHOOTING & REPAIR

TROUBLESHOOTING GUIDE

Observe Safety Guidelines
detailed in the beginning of this manual.

| PROBLEMS (SYMPTOMS) | POSSIBLE AREAS OF MISADJUSTMENT(S) | RECOMMENDED COURSE OF ACTION |
|------------------------------------------------------------------|-----------------------------------------------------------------------------------------------------------------------------------------------------------------------------------------------------------------------------------------------------------------------------------------------------------------------------------------------------------------------------------------------------------------------------------------------------------------------------------------------------------------------------------------------------------------|----------------------------------------------------------------------------------------------------------------------------------------------------------------------------------------------------------------------------------------------------------------------------------------------------------------------------------------------------------------------------------------------------------------------------------------------------------------------------------------------------------------|
| OUTPUT PROBLEMS | | |
| The V350-Pro does not have welding output. The displays are lit. | <ol style="list-style-type: none"> 1. Make sure the reconnect switch is configured correctly for the input voltage applied. 2. Make sure the Weld Terminals Select is ON. If the problem is solved the remote control device or associated circuitry may be faulty. See the wiring diagram. 3. Put the Control Select in the Local position. If the problem is solved the remote control device or associated circuitry may be faulty. 4. If an error code is displayed see Fault Code Explanations. | <ol style="list-style-type: none"> 1. Check the reconnect switch and associated leads for loose or faulty connections. See the wiring diagram. 2. Perform the Main Switch Board Test. 3. Perform the Power Board Test. 4. Perform the Output Diode Module Test. 5. The control board may be faulty. 6. The input filter capacitors may be faulty. Check and replace if necessary. 7. The remote board may be faulty. |
| The V350-Pro will not produce full output. | <ol style="list-style-type: none"> 1. The input voltage may be too low, limiting the output capability of the machine. Make certain the input voltage is correct for the machine and the reconnect switch and jumper lead configuration. 2. The welding current may be too high. The machine will fold back to 100 amps if the welding current exceeds 450 amps. 3. Make sure the machine is in "Local" output control. If the problem is resolved the Remote control board or the external remote control unit may be faulty. | <ol style="list-style-type: none"> 1. Perform the Output Rectifier Test. 2. Perform the Main Switch Board Test. 3. Perform the Power Board Test. 4. Perform the Current Transducer Test. 5. If the preset function is not performing properly the status panel board or the output control may be faulty. 6. The control board may be faulty. |



CAUTION

If for any reason you do not understand the test procedures or are unable to perform the test/repairs safely, contact the Lincoln Electric Service Department for electrical troubleshooting assistance before you proceed. Call 1-800-833-9353(WELD).

TROUBLESHOOTING & REPAIR

Observe Safety Guidelines detailed in the beginning of this manual.

TROUBLESHOOTING GUIDE

| PROBLEMS (SYMPTOMS) | POSSIBLE AREAS OF MISADJUSTMENT(S) | RECOMMENDED COURSE OF ACTION |
|---------------------------------------------------------------------------------------------------|------------------------------------------------------------------------------------------------------------------------------------------------------------------------------------------------------------------------------------------------------------------------------------------------------------------------------------------------------------------------------------------------------------------------------------------------------------------------------------------------------------------------------------------------------------------------------------------------------|------------------------------------------------------------------------------------------------------------------------------------------------------------------------------------------------------------------------------------------------------------------------------------------------------------------------------------------------------------------------------------------------------------------------------------------------------------------------------------------------------------------------------------------------------------|
| FUNCTION PROBLEMS | | |
| The machine regularly overheats and the yellow thermal light is ON indicating a thermal overload. | <ol style="list-style-type: none"> 1. Check the 3.5 amp circuit breaker (CB2). Reset if tripped. 2. The welding application may be exceeding the recommended duty cycle of the V350-Pro. 3. Dirt and dust may have clogged the cooling channels inside the machine. 4. Air intake and exhaust louvers may be blocked due to inadequate clearance around the machine. 5. Make certain the fan as needed (F.A.N.) is operating properly. The fan should operate when welding voltage is present and/or when there is an over temperature condition. | <ol style="list-style-type: none"> 1. The 115VAC fan motor is controlled by the control board via the main switch board. Perform the Fan Motor And Control Test. 1. A thermostat or associated circuitry may be faulty. See the wiring diagram. One normally closed thermostat is located on the output choke and the other is located on the main switch board heat sink. See the wiring diagram. <p>Note: The Main Switch Board Removal Procedure will be required to gain access to the heat sink thermostat.</p> |
| An attached wire feeder will not function correctly. | <ol style="list-style-type: none"> 1. Make certain the wire feeder control cable is connected to the correct 14-pin amphenol type plug (115VAC or 24/42VAC) for the wire feeder being used. See the connection diagram. If wirefeeder has DIP switch, be sure it is set correctly. 2. Check the two circuit breakers located at the rear of the machine. Reset if tripped. 3. The wire feeder or control cable may be faulty. | <ol style="list-style-type: none"> 1. Perform the Auxiliary Transformer Test. 2. Check the leads between the 14-pin amphenol type plugs and the auxiliary transformer for loose or faulty connections. |



CAUTION

If for any reason you do not understand the test procedures or are unable to perform the test/repairs safely, contact the Lincoln Electric Service Department for electrical troubleshooting assistance before you proceed. Call 1-800-833-9353(WELD).

V350-PRO



TROUBLESHOOTING & REPAIR

Observe Safety Guidelines detailed in the beginning of this manual.

TROUBLESHOOTING GUIDE

| PROBLEMS (SYMPTOMS) | POSSIBLE AREAS OF MISADJUSTMENT(S) | RECOMMENDED COURSE OF ACTION |
|------------------------------------------------------------------------------------|------------------------------------------------------------------------------------------------------------------------------------------------------------------------------------------------------------------------------------------------------|------------------------------------------------------------------------------------------------------------------------------------------------------------------------------------------------------------------------------------------------------------------------------------------------------------------------------------------------------------------------|
| FUNCTION PROBLEMS | | |
| The machine's welding output is very high and uncontrollable. | <ol style="list-style-type: none"> Put the Control Select in the Local position. If the problem is solved the remote control device or associated circuitry may be faulty. Check for proper current and voltage calibration. | <ol style="list-style-type: none"> Perform the Current Transducer Test. If the output is normal when the Control Select is in the Local position but the output is very high in the Remote position the remote board may be faulty. Perform The SPI Cable Resistance and Voltage Test. The control board may be faulty. |
| The Weld Mode Select does not function properly. | <ol style="list-style-type: none"> Refer to Operation Section of this manual for normal operation characteristics. <p>NOTE: The mode panel is not present if the advanced process panel is installed.</p> | <ol style="list-style-type: none"> Check for loose or faulty plug connections between the control board and the mode select panel. See the wiring diagram. Perform the SPI Cable Resistance and Voltage Test. The Mode Select Panel board may be faulty. The control board may be faulty. |
| The output control and/or Weld Terminals Select functions do not operate properly. | <ol style="list-style-type: none"> Refer to Operation Section of this manual for normal operation characteristics. Check for proper current and voltage calibration. | <ol style="list-style-type: none"> Check for loose or faulty plug connections between the remote board and the weld/output controls. See the wiring diagram. The Remote Board may be faulty. The control board may be faulty. |



CAUTION

If for any reason you do not understand the test procedures or are unable to perform the test/repairs safely, contact the Lincoln Electric Service Department for electrical troubleshooting assistance before you proceed. Call 1-800-833-9353(WELD).

V350-PRO



TROUBLESHOOTING & REPAIR

Observe Safety Guidelines detailed in the beginning of this manual.

TROUBLESHOOTING GUIDE

| PROBLEMS (SYMPTOMS) | POSSIBLE AREAS OF MISADJUSTMENT(S) | RECOMMENDED COURSE OF ACTION |
|-----------------------------------------------------------------|---------------------------------------------------------------------------------------------------------------------------------------------------------------------------------------------------------------------------------------------------------------------------------------------------------------------------------------------------------------------------------------------------------------|-------------------------------------------------------------------------------------------------------------------------------------------------------------------------------------------------------------------------------------------------------------------------------------------------------------------------------------------------|
| FUNCTION PROBLEMS | | |
| The display is not functioning properly. | <ol style="list-style-type: none"> 1. Refer to the Operation Section of this manual for normal operation characteristics. 2. Check for proper current and voltage calibration. | <ol style="list-style-type: none"> 1. Check for loose or faulty plug connections between the Display board and the control board. See the wiring diagram. 2. The display board may be faulty. 3. The control board may be faulty. |
| A fault or error code is displayed. | <ol style="list-style-type: none"> 1. See the Fault Code Explanations. | <ol style="list-style-type: none"> 1. See Fault Code Explanations. |
| For no apparent reason the welding characteristics have change. | <ol style="list-style-type: none"> 1. Check the welding cables for loose or faulty connection. 2. Make sure the machine's mode and output are set correctly for the process being used. (CV, CC,TIG etc.) 3. If Mig welding make sure the shielding gas and wire speed are correct for the process being used. 4. Check for proper current and voltage calibration. | <ol style="list-style-type: none"> 1. Perform the Voltage and Current Calibration Procedure. 2. Perform the Current Transducer Test. 3. Perform the Output Diode Module Test 4. The control board may be faulty. 5. The advanced process panel (If used) may be faulty. |



CAUTION

If for any reason you do not understand the test procedures or are unable to perform the test/repairs safely, contact the Lincoln Electric Service Department for electrical troubleshooting assistance before you proceed. Call 1-800-833-9353(WELD).

V350-PRO



TROUBLESHOOTING & REPAIR

| FAULT CODES | DESCRIPTION/ DEFINITION | CORRECTIVE ACTION | SERVICE FACILITY CORRECTIVE ACTION |
|-------------|---------------------------------------------|---------------------------------------------------------------------------------------------------------------------------------------------------------|--------------------------------------------------------------------------------------------------------------------------------------------------------------------------------------------------------------------------------------------------------------------|
| 31 | Main transformer primary over current | Turn the machine off and back on to reset the machine. If condition persists, contact an authorized Lincoln Field Service Facility. | <p>Perform the Main Switch Board Test.</p> <p>Perform the Power Board Test.</p> <p>There may be a problem with the primary current sensors (CT) located on the main switch board. See the Wiring diagram</p> <p>The control board may be faulty.</p> |
| 32 | Capacitor bank "A" (lower) is under voltage | Make sure the reconnect switches are configured for the input voltage being applied to the machine. The machine is self clearing when condition ceases. | <p>There may be a problem with the V/F signals from the main switch board to the control board.</p> <p>Perform the Main Switch Board Test.</p> <p>Perform the Power Board Test.</p> <p>The control board may be faulty.</p> |

NOTE: If more than one fault message is being displayed, perform all the checks for the faults before replacing the printed circuit board

V350-PRO



TROUBLESHOOTING & REPAIR

| FAULT CODES | DESCRIPTION/ DEFINITION | CORRECTIVE ACTION | SERVICE FACILITY CORRECTIVE ACTION |
|-------------|---------------------------------------------|---------------------------------------------------------------------------------------------------------------------------------------------------------|-------------------------------------------------------------------------------------------------------------------------------------------------------------------------------------------------------------------------------------------|
| 33 | Capacitor bank "B"(upper) is under voltage. | Make sure the reconnect switches are configured for the input voltage being applied to the machine. The machine is self-clearing when condition ceases. | <p>There may be a problem with the V/F signals from the main switch board to the control board.</p> <p>Perform the Main Switch Board Test.</p> <p>Perform the Power Board Test.</p> <p>The control board may be faulty.</p> |
| 34 | Capacitor bank "A"(lower) is over voltage. | Make sure the reconnect switches are configured for the input voltage being applied to the machine. The machine is self-clearing when condition ceases. | <p>There may be a problem with the V/F signals from the main switch board to the control board.</p> <p>Perform the Main Switch Board Test.</p> <p>Perform the Power Board Test.</p> <p>The control board may be faulty.</p> |

NOTE: If more than one fault message is being displayed, perform all the checks for the faults before replacing the printed circuit board

V350-PRO



TROUBLESHOOTING & REPAIR

| FAULT CODES | DESCRIPTION/ DEFINITION | CORRECTIVE ACTION | SERVICE FACILITY CORRECTIVE ACTION |
|-------------|--------------------------------------------|---------------------------------------------------------------------------------------------------------------------------------------------------------|-------------------------------------------------------------------------------------------------------------------------------------------------------------------------------------------------------------------------------------------|
| 35 | Capacitor bank "B"(lower) is over voltage. | Make sure the reconnect switches are configured for the input voltage being applied to the machine. The machine is self-clearing when condition ceases. | <p>There may be a problem with the V/F signals from the main switch board to the control board.</p> <p>Perform the Main Switch Board Test.</p> <p>Perform the Power Board Test.</p> <p>The control board may be faulty.</p> |
| 37 | The soft start function failed. | Turn the machine off and back on to reset the machine. | <p>There may be a problem with the V/F signals from the main switch board to the control board.</p> <p>Perform the Main Switch Board Test.</p> <p>Perform the Power Board Test.</p> <p>The control board may be faulty.</p> |

NOTE: If more than one fault message is being displayed, perform all the checks for the faults before replacing the printed circuit board
V350-PRO

TROUBLESHOOTING & REPAIR

| FAULT CODES | DESCRIPTION/ DEFINITION | CORRECTIVE ACTION | SERVICE FACILITY CORRECTIVE ACTION |
|-------------|-------------------------------------------------------------------------|----------------------------------------------------------------------------------------------------------------------------------------------------------------------|---------------------------------------------------------------------------------------------------------------------------------------------------------------------------------------------------------------------------------------------------------------------|
| 39 | Electrical "glitch" on the primary over current fault detector circuit. | Possibly caused by an external electrical "noise" or signal level. Make sure the V350-Pro is grounded correctly. The machine is self clearing when condition ceases. | <p>Perform the Main Switch Board Test.</p> <p>Perform the Power Board Test.</p> <p>There may be a problem with the primary current sensors (CT) located on the main switch board. See the wiring diagram.</p> <p>The control board may be faulty.</p> |
| 43 | Capacitor banks "A" (lower) and "B"(upper) are not balanced. | Make sure the reconnect switches are configured for the input voltage being applied to the machine. The machine is self-clearing when condition ceases. | <p>There may be a problem with the V/F signals from the main switch board to the control board.</p> <p>Perform the Main Switch Board Test.</p> <p>The capacitor(s) may be faulty. Check and replace if necessary.</p> |
| 44 | The machine has detected a fault in the central processing unit (CPU). | Make sure the V350-Pro is grounded correctly. The machine is self clearing when condition ceases. | <p>Perform the Power Board Test.</p> <p>The control board or associated wiring may be faulty. See the wiring diagram.</p> |

NOTE: If more than one fault message is being displayed, perform all the checks for the faults before replacing the printed circuit board

V350-PRO



TROUBLESHOOTING & REPAIR

| FAULT CODES | DESCRIPTION/ DEFINITION | CORRECTIVE ACTION | SERVICE FACILITY CORRECTIVE ACTION |
|-------------------|--------------------------------------------------------------------------------------------------|----------------------------------------------------------------------------------------------------------------------------------------------------------------------|------------------------------------------------------------------------------------------------------------------------------------------------------------------------------------------------------------------------------------------------------------------|
| 47 | Electrical "glitch" on the V/F signals from the main switch board to the control board. | Possibly caused by an external electrical "noise" or signal level. Make sure the V350-Pro is grounded correctly. The machine is self clearing when condition ceases. | <p>There may be a problem with the V/F signals from the main switch board to the control board.</p> <p>Perform the Main Switch Board Test.</p> <p>Perform the Power Board Test.</p> <p>The control board may be faulty.</p> |
| "bad node" "####" | The selected weld mode does not exist in the weld table that is presently loaded in the machine. | Press the Mode Select button to select a different welding mode. | <p>If new software was just installed, try reinstalling the software or put the original software back.</p> <p>Perform the Power Board Test.</p> <p>Perform the SPI Cable Resistance and Voltage Test.</p> <p>The control board may be faulty.</p> |

NOTE: If more than one fault message is being displayed, perform all the checks for the faults before replacing the printed circuit board

V350-PRO



V350-PRO



INPUT FILTER CAPACITOR DISCHARGE PROCEDURE



WARNING

Service and repair should be performed by only Lincoln Electric factory trained personnel. Unauthorized repairs performed on this equipment may result in danger to the technician or machine operator and will invalidate your factory warranty. For your safety and to avoid electrical shock, please observe all safety notes and precautions detailed throughout this manual.

If for any reason you do not understand the test procedures or are unable to perform the test/repairs safely, contact the Lincoln Electric Service Department for electrical troubleshooting assistance before you proceed. Call 1-800-833-9353 (WELD).

DESCRIPTION

This procedure will drain off any charge stored in the four large capacitors that are part of the switch board assembly. This procedure **MUST** be performed, as a safety precaution, before conducting any test or repair procedure that requires you to touch internal components of the machine.

MATERIALS NEEDED

5/16" Nut Driver
Insulated Pliers
Insulated Gloves
High Wattage Resistor (25-1000 ohms and 25 watts minimum)
DC Volt Meter

This procedure takes approximately 20 minutes to perform.

V350-PRO



INPUT FILTER CAPACITOR DISCHARGE PROCEDURE *(continued)*

⚠ WARNING

ELECTRIC SHOCK can kill.



- Have an electrician install and service this equipment.
- Turn the input power off at the fuse box before working on equipment.
- Do not touch electrically hot parts.
- Prior to performing preventative maintenance, perform the following capacitor discharge procedure to avoid electric shock.

DISCHARGE PROCEDURE

1. Remove the input power to the V350-PRO.
2. Using the 5/16" wrench remove the screws from the case wraparound cover.
3. Be careful not to make contact with the capacitor terminals located at the top and bottom of the switch board.
4. Obtain a high resistance and high wattage resistor (25-1000 ohms and 25 watts minimum). This resistor is not with the machine. NEVER USE A SHORTING STRAP FOR THIS PROCEDURE.
5. Locate the eight capacitor terminals shown in figure F.1.
6. Using electrically insulated gloves and pliers, hold the body of the resistor with the pliers and connect the resistor leads across the two capacitor terminals. Hold the resistor in place for 10 seconds. DO NOT TOUCH CAPACITOR TERMINALS WITH YOUR BARE HANDS.
7. Repeat the discharge procedure for the other three capacitors.
8. Check the voltage across the terminals of all capacitors with a DC voltmeter. Polarity of the capacitor terminals is marked on the PC board above the terminals. Voltage should be zero. If any voltage remains, repeat this capacitor discharge procedure.

FIGURE F.1 – LOCATION OF INPUT FILTER CAPACITOR TERMINALS

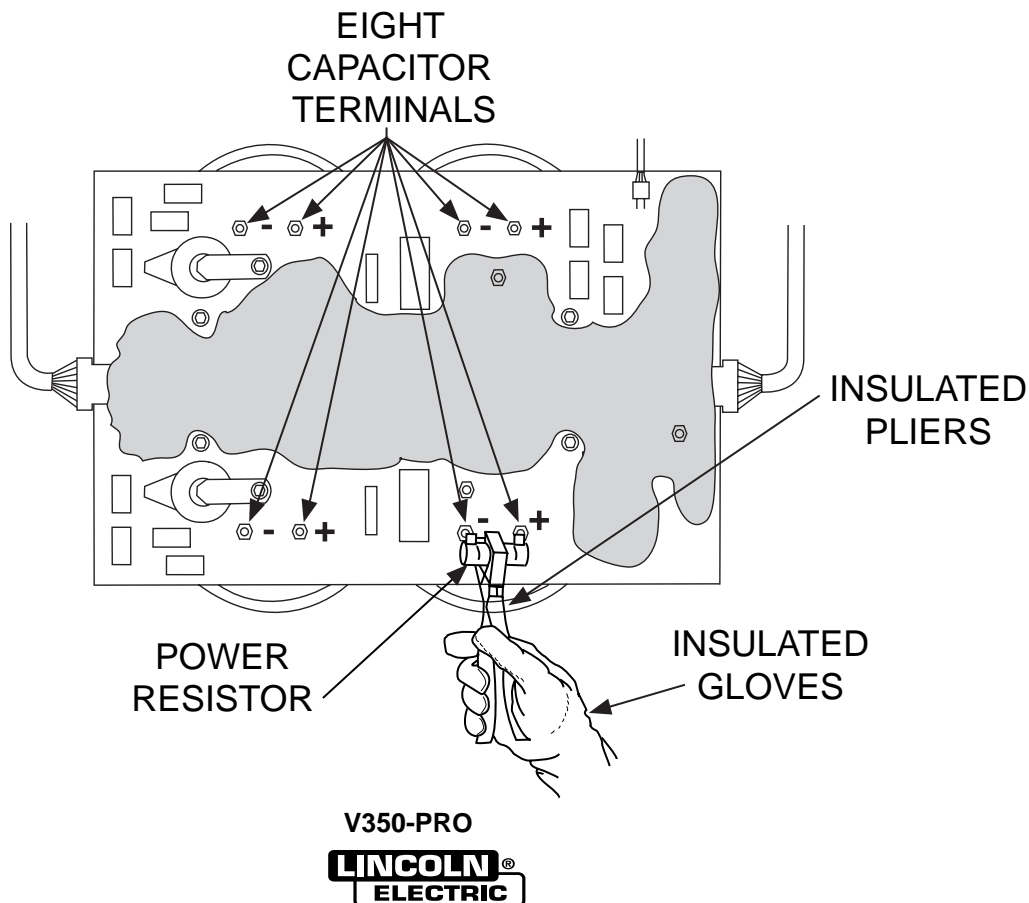

MAIN SWITCH BOARD TEST



WARNING

Service and repair should be performed by only Lincoln Electric factory trained personnel. Unauthorized repairs performed on this equipment may result in danger to the technician or machine operator and will invalidate your factory warranty. For your safety and to avoid electrical shock, please observe all safety notes and precautions detailed throughout this manual.

If for any reason you do not understand the test procedures or are unable to perform the test/repairs safely, contact the Lincoln Electric Service Department for electrical troubleshooting assistance before you proceed. Call 1-800-833-9353 (WELD).

DESCRIPTION

This test will help determine if the “power section” of the switch boards are functioning correctly. This test will NOT indicate if the entire PC board is functional. This resistance test is preferable to a voltage test with the machine energized because this board can be damaged easily. In addition, it is dangerous to work on this board with the machine energized.

MATERIALS NEEDED

Analog Volt/Ohmmeter
5/16 in. Wrench
7/16 in. Wrench

This procedure takes approximately 30 minutes to perform.

V350-PRO



MAIN SWITCH BOARD TEST (continued)

FIGURE F.2 MAIN SWITCH BOARD LEAD LOCATIONS

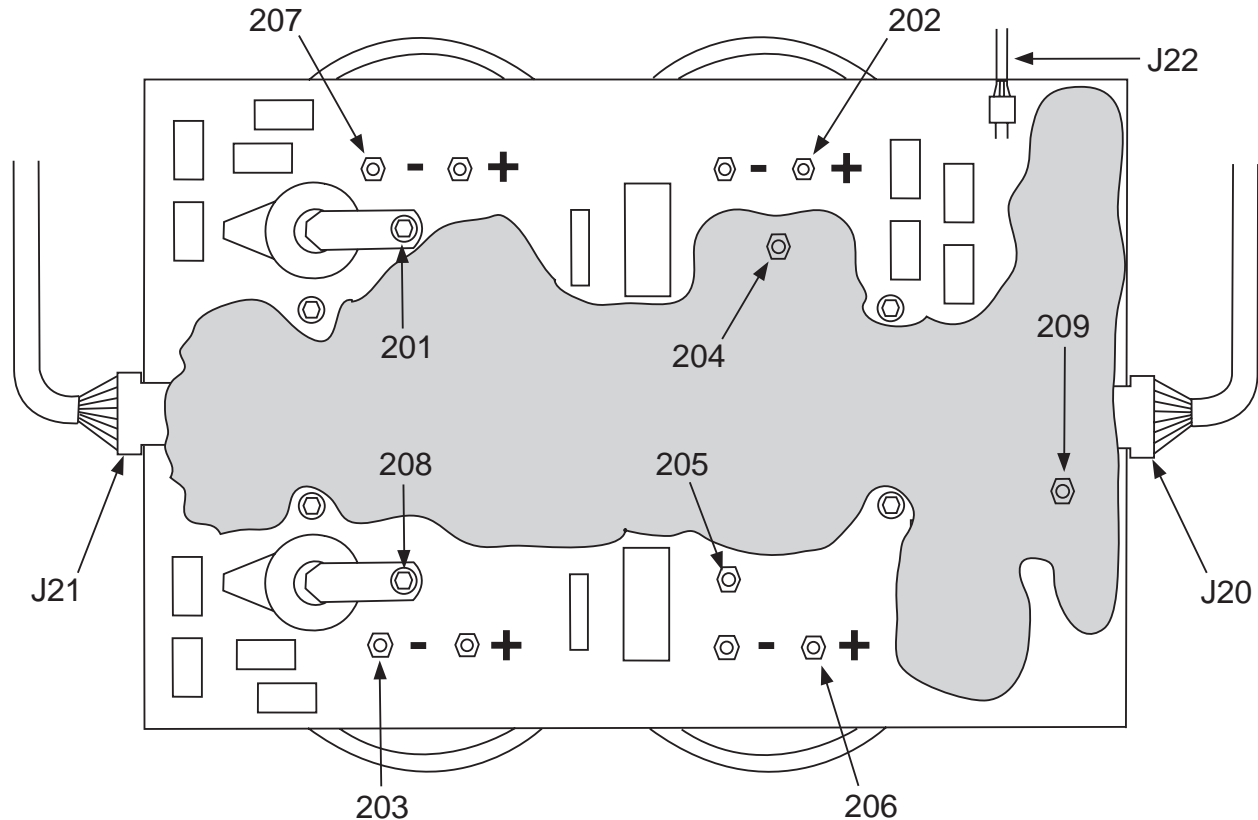

TEST PROCEDURE

1. Remove input power to the V350-PRO.
2. Using a 5/16" nut driver, remove the case wraparound.
3. Perform the **Input Filter Capacitor Discharge Procedure** detailed earlier in this section.
4. Using a 7/16" wrench locate, label and remove leads 201, 202, 203, 204, 205, 206, 207 and 208 from the switch board. Note lead and washer placement for reassembly. Clear leads.
5. Using the Analog ohmmeter, perform the resistance tests detailed in **Table F.1**. Refer to figure F.2 for test point locations. Note: Test using an Analog ohmmeter on the Rx1 range. Make sure the test probes are making electrical contact with the conductor surfaces on the PC board.

V350-PRO

LINCOLN[®]
ELECTRIC

MAIN SWITCH BOARD TEST *(continued)*

6. If any test fails replace the switch board. See **Main Switch Board Removal and Replacement.**
7. If the switch board resistance tests are OK, check connections on plugs J20, J21, J22 and all associated wiring. See wiring diagram.
8. Reconnect leads 201, 202, 203, 204, 205, 206, 207, and 208 to the switch board. Ensure that the leads are installed in their proper locations. Pre-Torque all leads nuts to 25 inch lbs. before tightening them to 44 inch lbs.
9. Replace the case wraparound cover using a 5/16" nut driver.

TABLE F.1. SWITCH BOARD RESISTANCE TEST

| APPLY POSITIVE TEST PROBE TO TERMINAL | APPLY NEGATIVE TEST PROBE TO TERMINAL | NORMAL RESISTANCE READING |
|---------------------------------------|---------------------------------------|---------------------------|
| +206 | -205 | Greater than 1000 ohms |
| +208 | -203 | Greater than 1000 ohms |
| +202 | -204 | Greater than 1000 ohms |
| +201 | -207 | Greater than 1000 ohms |
| +205 | -206 | Less than 100 ohms |
| +203 | -208 | Less than 100 ohms |
| +204 | -202 | Less than 100 ohms |
| +207 | -201 | Less than 100 ohms |

V350-PRO



TROUBLESHOOTING & REPAIR

INPUT RECTIFIER TEST



WARNING

Service and repair should be performed by only Lincoln Electric factory trained personnel. Unauthorized repairs performed on this equipment may result in danger to the technician or machine operator and will invalidate your factory warranty. For your safety and to avoid electrical shock, please observe all safety notes and precautions detailed throughout this manual.

If for any reason you do not understand the test procedures or are unable to perform the test/repairs safely, contact the Lincoln Electric Service Department for electrical troubleshooting assistance before you proceed. Call 1-800-833-9353 (WELD).

DESCRIPTION

This test will help determine if the input rectifier has “shorted” or “open” diodes.

MATERIALS NEEDED

- Analog Voltmeter/Ohmmeter (Multimeter)
- 5/16” Nut Driver
- Phillips Head Screwdriver
- Wiring Diagram

This procedure takes approximately 25 minutes to perform.

V350-PRO



TROUBLESHOOTING & REPAIR

INPUT RECTIFIER TEST (CONTINUED)

TEST PROCEDURE

1. Remove input power to the V350-PRO machine.
2. Using a 5/16" nut driver, remove the case wraparound cover.
3. Perform the **Capacitor Discharge Procedure** detailed earlier in this section.
4. Locate the input rectifier and associated leads. See Figure F.3.
5. Carefully remove the silicone sealant from leads 207, 207A, and 209.
6. Using a phillips head screwdriver, remove leads 207, 207A, and 209 from the input rectifier.
7. Use the analog ohmmeter to perform the tests detailed in **Table F.2**. See the Wiring Diagram.
8. Visually inspect the three MOV'S for damage (TP1,TP2,TP3). Replace if necessary.

Figure F.3 Input Rectifier

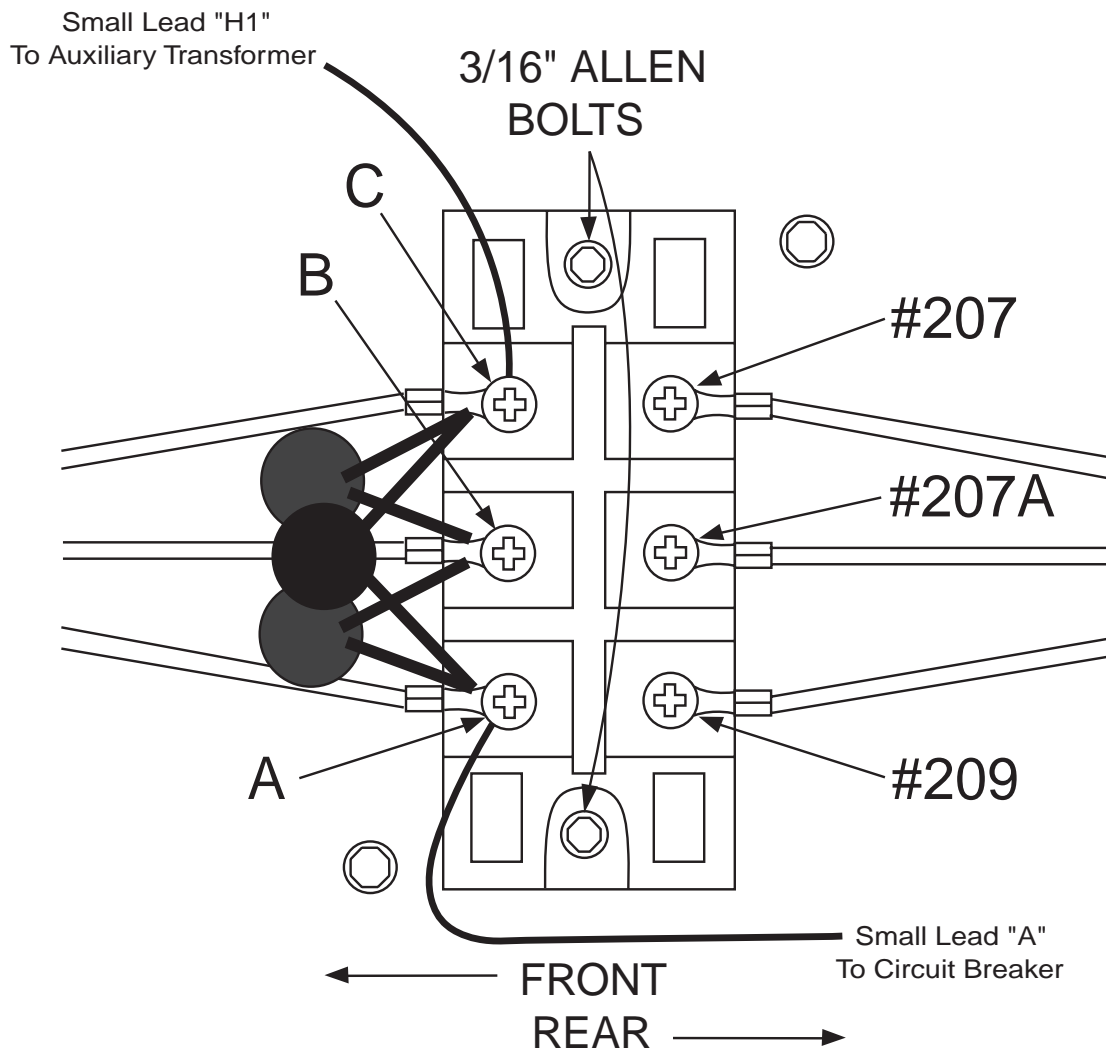

V350-PRO

LINCOLN[®]
ELECTRIC

TROUBLESHOOTING & REPAIR

INPUT RECTIFIER TEST (CONTINUED)

Table F.2 Input Rectifier Test Points

| TEST POINT TERMINALS | | ANALOG METER X10 RANGE |
|----------------------|---------|---------------------------|
| + PROBE | - PROBE | Acceptable Meter Readings |
| A | 207 | Greater than 1000 ohms |
| B | 207 | Greater than 1000 ohms |
| C | 207 | Greater than 1000 ohms |
| A | 207A | Greater than 1000 ohms |
| B | 207A | Greater than 1000 ohms |
| C | 207A | Greater than 1000 ohms |
| A | 209 | Less than 100 ohms |
| B | 209 | Less than 100 ohms |
| C | 209 | Less than 100 ohms |
| 207 | A | Less than 100 ohms |
| 207 | B | Less than 100 ohms |
| 207 | C | Less than 100 ohms |
| 207A | A | Less than 100 ohms |
| 207A | B | Less than 100 ohms |
| 207A | C | Less than 100 ohms |
| 209 | A | Greater than 1000 ohms |
| 209 | B | Greater than 1000 ohms |
| 209 | C | Greater than 1000 ohms |

9. If the input rectifier does not meet the acceptable readings outlined in Table F.2 the component may be faulty. Replace

Note: Before replacing the input rectifier, check the input power switch and perform the **Main Switch Board Test**. Also check for leaky or faulty filter capacitors.

10. If the input rectifier is good, be sure to reconnect leads 207, 207A, and 209 to the correct terminals and torque to 31 inch lbs. Apply silicone sealant.

11. If the input rectifier is faulty, see the **Input Rectifier Bridge Removal & Replacement** procedure.

12. Replace the case wraparound cover.

V350-PRO



V350-PRO



TROUBLESHOOTING & REPAIR

POWER BOARD TEST



WARNING

Service and repair should be performed by only Lincoln Electric factory trained personnel. Unauthorized repairs performed on this equipment may result in danger to the technician or machine operator and will invalidate your factory warranty. For your safety and to avoid electrical shock, please observe all safety notes and precautions detailed throughout this manual.

If for any reason you do not understand the test procedures or are unable to perform the test/repairs safely, contact the Lincoln Electric Service Department for electrical troubleshooting assistance before you proceed. Call 1-800-833-9353 (WELD).

DESCRIPTION

This test will help determine if the power board is receiving the correct voltages and also if the power board is regulating and producing the correct DC voltages.

MATERIALS NEEDED

Volt-Ohmmeter
5/16" Nut Driver
Wiring Diagram

This procedure takes approximately 30 minutes to perform.

V350-PRO



TROUBLESHOOTING & REPAIR

POWER BOARD TEST (CONTINUED)

TEST PROCEDURE

1. Remove input power to the V350-PRO machine.
2. Using a 5/16" nut driver, remove the case wraparound cover.
3. Perform the **Capacitor Discharge Procedure** detailed earlier in this section.
4. Locate the power board and plugs J41, J42 and J43. **Do not remove plugs from the power board.** See Figure F.4.
5. Carefully apply the correct input voltage to the V350-PRO.
6. Carefully test for the correct voltages at the power board. **See Table F.3.**
7. If the 40VDC is low, or not present at plug J41, check the rectifier bridge and C5 filter capacitor. See Wiring Diagram. Also perform the **Auxiliary Transformer Test.**
8. If any of the DC voltages are low, or not present at plugs J42 or J43, the power board may be faulty.
9. Remove the input power to the V350-PRO.
10. Replace the case wraparound cover using a 5/16" nut driver.

Figure F.4 Power Board Plug Location

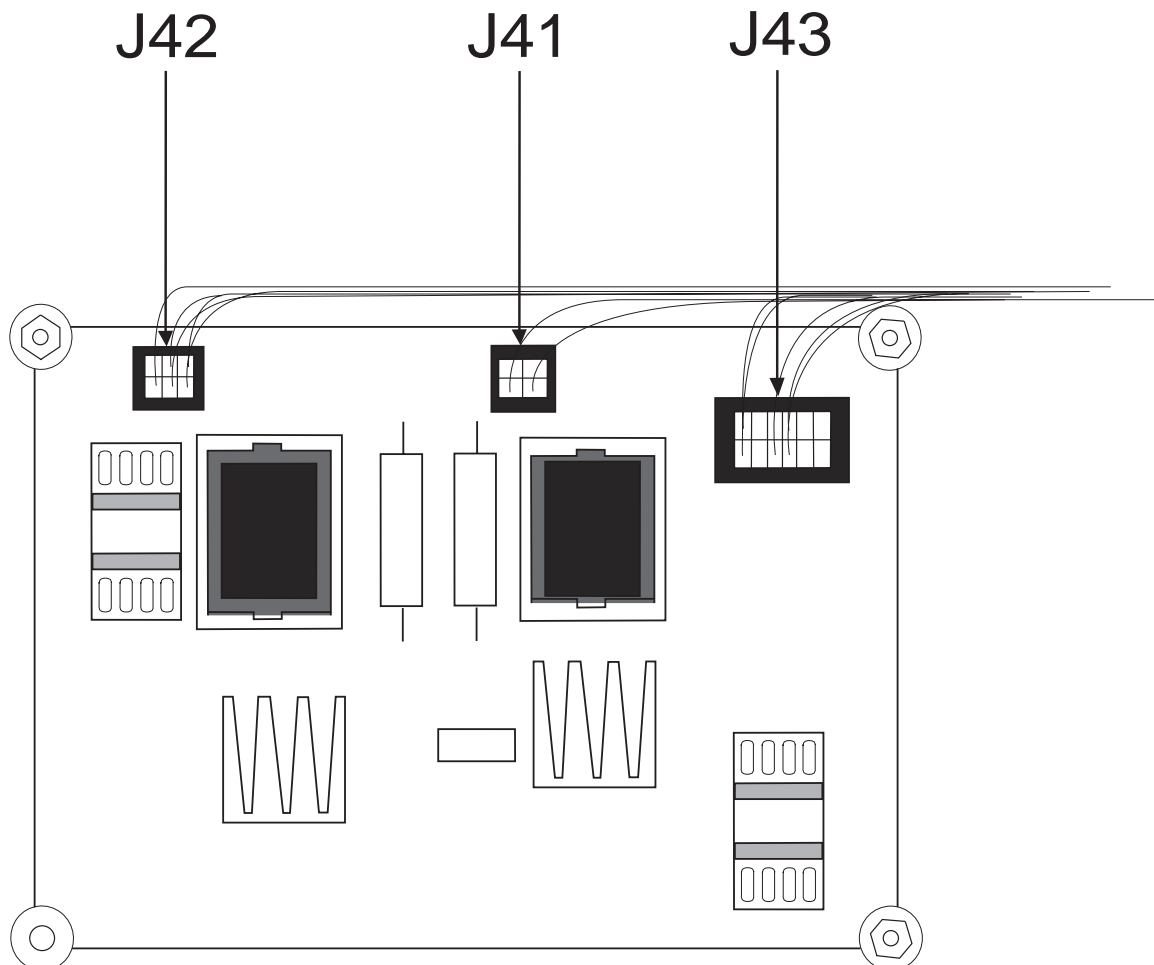

V350-PRO

LINCOLN[®]
ELECTRIC

TROUBLESHOOTING & REPAIR

POWER BOARD TEST (CONTINUED)

Table F.3 Power Board Voltage Checks

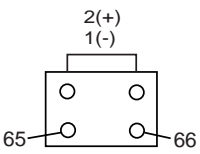
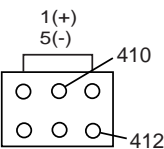
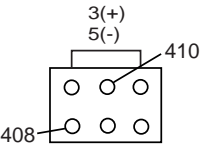
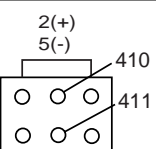
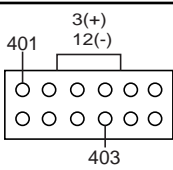
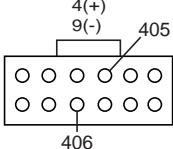
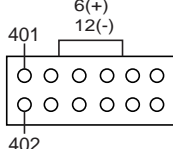
| CHECK POINT LOCATION | TEST DESCRIPTION | CONNECTOR PLUG PIN NO. | LEAD NO. OR IDENTITY | NORMAL ACCEPTABLE VOLTAGE READING |
|-----------------------------------|---------------------------------------------------|-------------------------------------------------------------------------------------|----------------------|-----------------------------------|
| POWER PC BOARD CONNECTOR PLUG J41 | CHECK 40VDC SUPPLY FROM RECT. BRIDGE TO POWER BD. |  | 65 (+) 66 (-) | 38-42 VDC |
| POWER PC BOARD CONNECTOR PLUG J42 | CHECK +15VDC SUPPLY FROM POWER PC BOARD |  | 412 (+) 410 (-) | 15 VDC |
| POWER PC BOARD CONNECTOR PLUG J42 | CHECK +5VDC SUPPLY FROM POWER PC BOARD |  | 408 (+) 410 (-) | 5 VDC |
| POWER PC BOARD CONNECTOR PLUG J42 | CHECK -15VDC SUPPLY FROM POWER PC BOARD |  | 411 (+) 410 (-) | -15 VDC |
| POWER PC BOARD CONNECTOR PLUG J43 | CHECK +5VDC "SPI" SUPPLY FROM POWER PC BOARD |  | 403 (+) 401 (-) | 5 VDC |
| POWER PC BOARD CONNECTOR PLUG J43 | CHECK +5VDC "RS232" SUPPLY FROM POWER PC BOARD |  | 406 (+) 405 (-) | 5 VDC |
| POWER PC BOARD CONNECTOR PLUG J43 | CHECK +15VDC "SPI" SUPPLY FROM POWER PC BOARD |  | 402 (+) 401 (-) | 15 VDC |

V350-PRO

LINCOLN[®]
ELECTRIC

V350-PRO



TROUBLESHOOTING & REPAIR

OUTPUT DIODE MODULES TEST



WARNING

Service and repair should be performed by only Lincoln Electric factory trained personnel. Unauthorized repairs performed on this equipment may result in danger to the technician or machine operator and will invalidate your factory warranty. For your safety and to avoid electrical shock, please observe all safety notes and precautions detailed throughout this manual.

If for any reason you do not understand the test procedures or are unable to perform the test/repairs safely, contact the Lincoln Electric Service Department for electrical troubleshooting assistance before you proceed. Call 1-800-833-9353 (WELD).

DESCRIPTION

This test will help determine if any of the output diodes are “shorted”.

MATERIALS NEEDED

Analog Voltmeter/Ohmmeter
Wiring Diagram

This procedure takes approximately 20 minutes to perform.

V350-PRO



TROUBLESHOOTING & REPAIR

OUTPUT DIODE MODULES TEST *(continued)*

FIGURE F.5 Machine Output Terminals

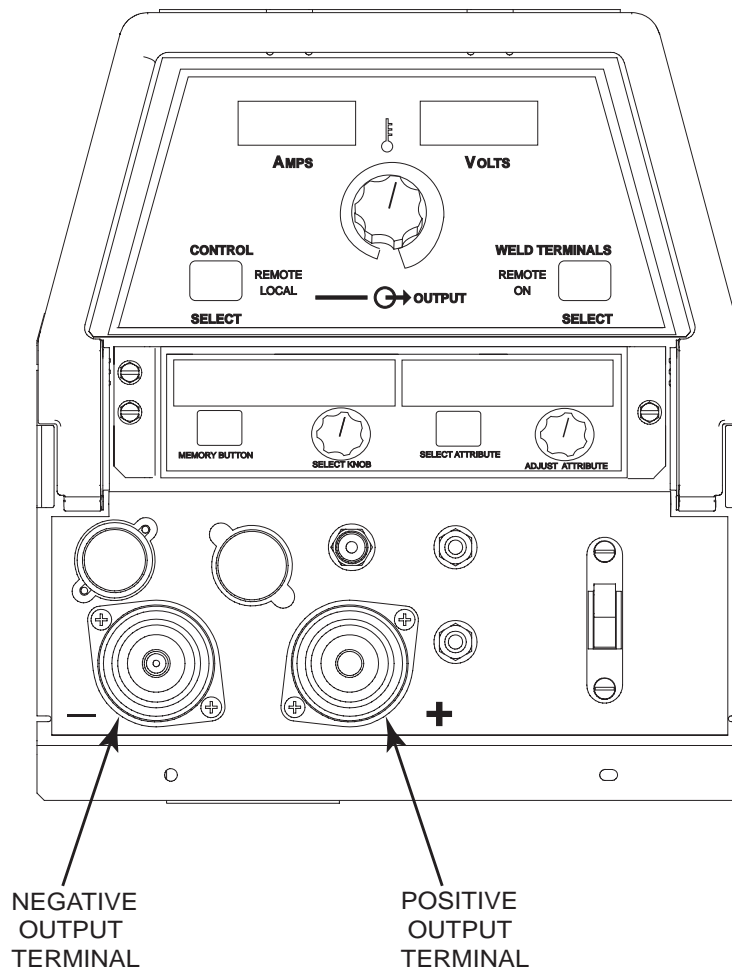

TEST PROCEDURE

1. Remove input power to the V350-PRO.
2. Locate the output terminals on the front panel of the machine. See Figure F.5.
3. Remove any output cables and load from the output terminals.
4. Using the analog ohmmeter test for more than 200 ohms resistance between positive and negative output terminals. Positive test lead to the positive terminal; Negative test lead to the negative terminal. **See Figure F.6.**

NOTE: The polarity of the test leads is most important. If the test leads polarity is not correct, the test will have erroneous results.

V350-PRO

LINCOLN[®]
ELECTRIC

TROUBLESHOOTING & REPAIR

OUTPUT DIODE MODULES TEST (continued)

Figure F.6 Terminal Probes

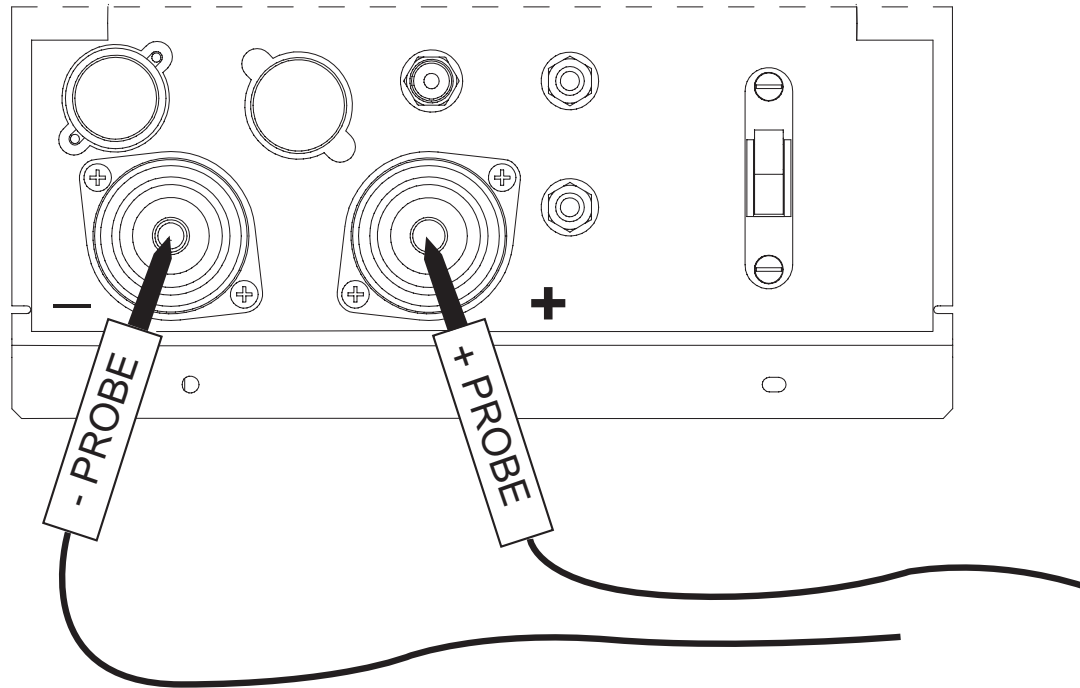

5. If 200 ohms is measured then the output diodes are not “shorted”.

NOTE: There is a 250 ohm resistor across the welding output terminals.

6. If less than 200 ohms is measured, one or more diodes or the snubber board may be faulty.
7. Perform the **Filter Capacitor Discharge Procedure** detailed earlier in this section.
8. Locate the output diode modules and snubber board. **See Figure F.7.**
9. Test all output diode modules individually.

NOTE: This may require the disassembly of the leads and the snubber board from the diode modules. Refer to the **Output Diode Modules Removal and Replacement Procedure** for detailed instructions.

V350-PRO

LINCOLN[®]
ELECTRIC

TROUBLESHOOTING & REPAIR

OUTPUT DIODE MODULES TEST *(continued)*

Figure F.7 Snubber and Output Diode Locations

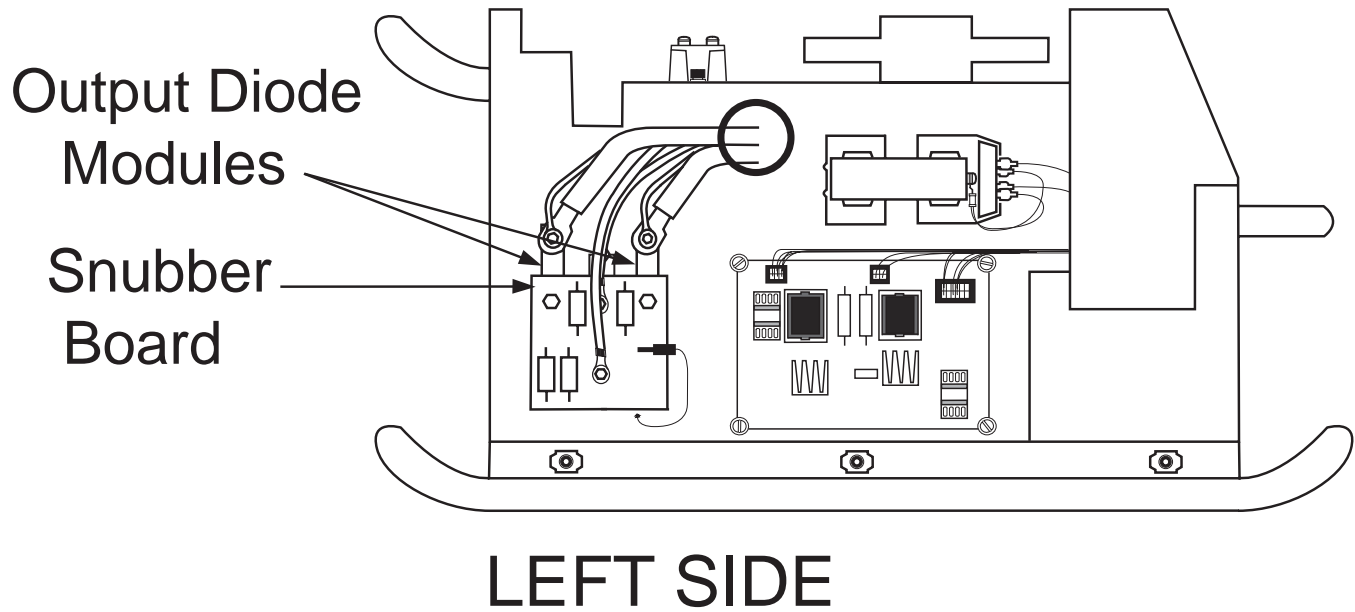

V350-PRO

LINCOLN[®]
ELECTRIC

TROUBLESHOOTING & REPAIR

AUXILIARY TRANSFORMER TEST



WARNING

Service and repair should be performed by only Lincoln Electric factory trained personnel. Unauthorized repairs performed on this equipment may result in danger to the technician or machine operator and will invalidate your factory warranty. For your safety and to avoid electrical shock, please observe all safety notes and precautions detailed throughout this manual.

If for any reason you do not understand the test procedures or are unable to perform the test/repairs safely, contact the Lincoln Electric Service Department for electrical troubleshooting assistance before you proceed. Call 1-800-833-9353 (WELD).

DESCRIPTION

This procedure will determine if the correct voltage is being applied to the primary of auxiliary transformer and also if the correct voltage is being induced on the secondary windings of the transformer.

MATERIALS NEEDED

- Volt-ohmmeter (Multimeter)
- 5/16" Nut Driver
- Wiring Diagram

This procedure takes approximately 25 minutes to perform.

V350-PRO



TROUBLESHOOTING & REPAIR

AUXILIARY TRANSFORMER TEST (continued)

FIGURE F.8 Auxiliary Transformer

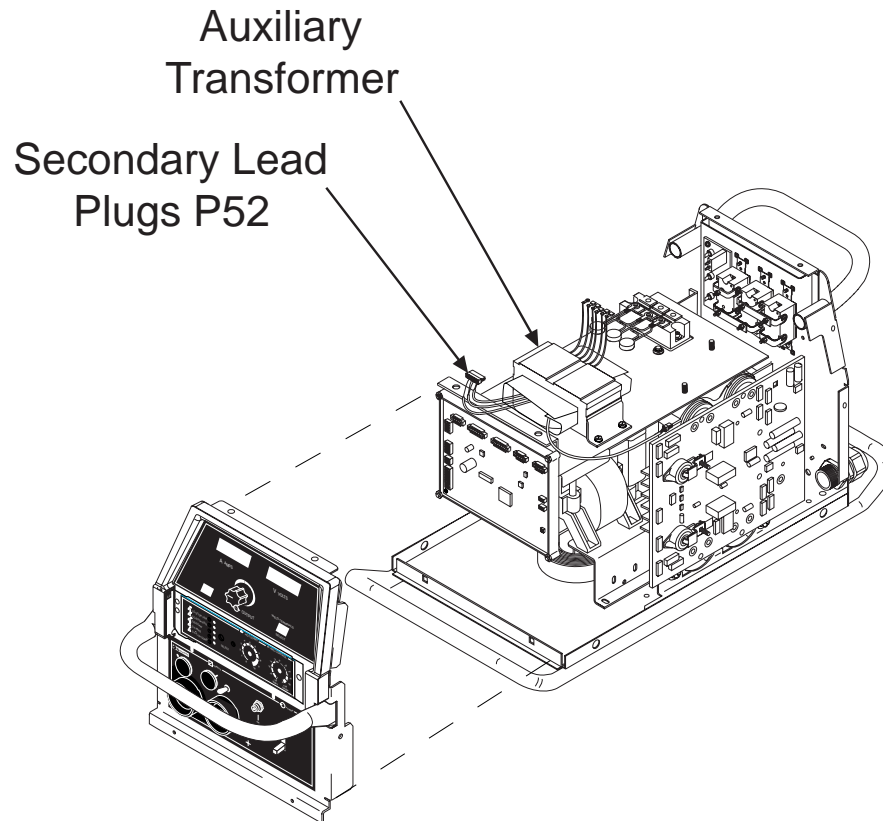

TEST PROCEDURE

1. Remove input power to the V350-PRO.
2. Using a 5/16" nut driver, remove the case wraparound cover.
3. Perform the **Input Capacitor Discharge Procedure** detailed earlier in this section.
4. Locate the auxiliary transformer. See Figure F.8.
5. Locate the secondary leads and plug P52. See Figure F.8 and F.9.

FIGURE F.9 Plug Lead Connections Viewed From Transformer Lead Side of Plug

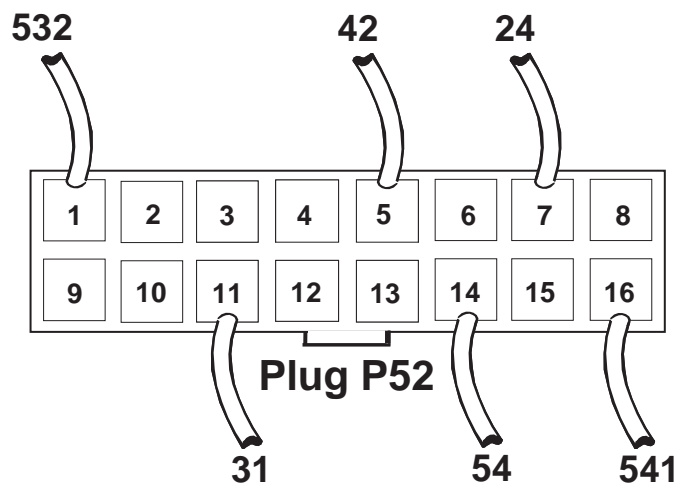

V350-PRO

LINCOLN[®]
ELECTRIC

TROUBLESHOOTING & REPAIR

AUXILIARY TRANSFORMER NO.1 TEST *(continued)*

TABLE F.4

| LEAD IDENTIFICATION | NORMAL EXPECTED VOLTAGE |
|---------------------|-------------------------|
| 31 TO 532 | 115 VAC |
| 42 TO 541 | 42 VAC |
| 24 TO 541 | 24 VAC |
| 54 TO 541 | 28 VAC |

7. Carefully apply the correct input voltage to the V350-PRO and check for the correct secondary voltages per table F.4. Make sure the reconnect jumper lead and switch are configured correctly for the input voltage being applied. Make sure circuit breaker (CB3) is functioning properly.

NOTE: The secondary voltages will vary if the input line voltage varies.

8. If the correct secondary voltages are present, the auxiliary transformer is functioning properly. If any of the secondary voltages are missing or low, check to make certain the primary is configured correctly for the input voltage applied. See Wiring Diagram.



WARNING

High voltage is present at primary of Auxiliary Transformer.

9. If the correct input voltage is applied to the primary, and the secondary voltage(s) are not correct, the auxiliary transformer may be faulty.
10. Remove the input power to the V350-PRO.
11. Install the case wraparound cover using a 5/16" nut driver.

V350-PRO



V350-PRO



TROUBLESHOOTING AND REPAIR

CURRENT TRANSDUCER TEST



WARNING

Service and repair should be performed by only Lincoln Electric factory trained personnel. Unauthorized repairs performed on this equipment may result in danger to the technician or machine operator and will invalidate your factory warranty. For your safety and to avoid electrical shock, please observe all safety notes and precautions detailed throughout this manual.

If for any reason you do not understand the test procedures or are unable to perform the test/repairs safely, contact the Lincoln Electric Service Department for electrical troubleshooting assistance before you proceed. Call 1-800-833-9353 (WELD).

DESCRIPTION

This test will help determine if the current transducer and associated wiring are functioning correctly.

MATERIALS NEEDED

Volt-ohmmeter
5/16" Nut Driver
Resistive Load Bank
External DC Ammeter

This procedure takes approximately 45 minutes to perform.

V350-PRO



TROUBLESHOOTING AND REPAIR

CURRENT TRANSDUCER TEST (continued)

FIGURE F.10 Metal Plate Removal & Plug J8 Location

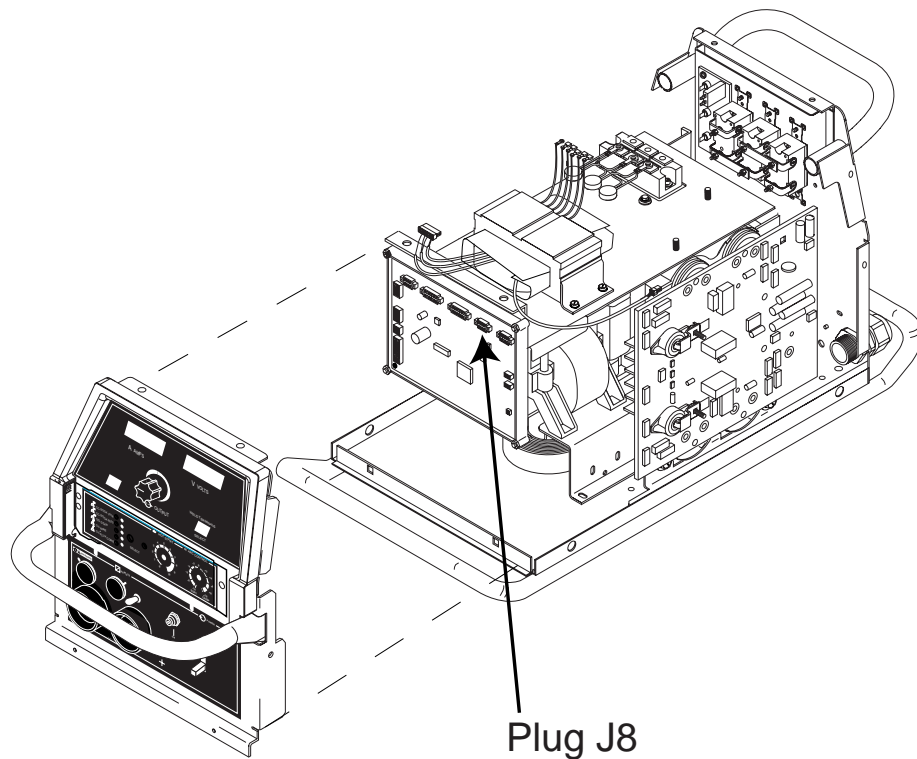

TEST PROCEDURE

1. Remove input power to the V350-PRO.
2. Using the 5/16" nut driver, remove the case wraparound cover.
3. Perform the **Input Capacitor Discharge Procedure**.
4. Locate plug J8 on the control board. Do not remove the plug from the P.C. Board.
5. Apply the correct input power to the V350-PRO.
6. Check for the correct DC supply voltages to the current transducer at plug J8. See Figure F.11.
 - A. Pin 2 (lead 802+) to pin 6 (lead 806-) should read +15 VDC.
 - B. Pin 4 (lead 804+) to pin 6 (lead 806-) should read -15 VDC.
7. If either of the supply voltages are low or missing, the control board may be faulty.

FIGURE F.11. Plug J8 Viewed From Lead Side of Plug

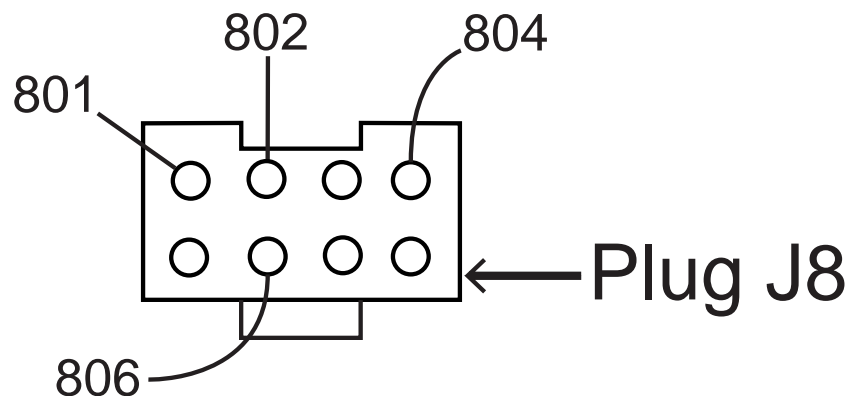

V350-PRO

LINCOLN[®]
ELECTRIC

TROUBLESHOOTING AND REPAIR

CURRENT TRANSDUCER TEST *(continued)*

TABLE F.5

| OUTPUT LOAD CURRENT | EXPECTED TRANSDUCER FEEDBACK VOLTAGE |
|---------------------|--------------------------------------|
| 300 | 2.4 |
| 250 | 2.0 |
| 200 | 1.6 |
| 150 | 1.2 |
| 100 | 0.8 |

8. Check the feedback voltage from the current transducer using a resistive load bank and with the V350-PRO in mode 200. Mode 200 is a constant current test mode. This mode can be accessed from the front panel of the V350 by pressing and holding the Mode Select button while turning the machine on. **NOTE:** Machines with an Advanced Process Panels do not have a mode select button. Use the same procedure except hold in the Memory button on the advanced process panel instead of the mode select button. Then, rotate the output knob while still holding the Mode Select button in until the displays read "Mode 200". Release the Mode Select Button and the machine will be in mode 200. With the V350-PRO in mode 200, apply the grid load across the output of the V350-PRO, set machine output to 300 amps and enable WELD TERMINALS. Adjust the grid load to obtain 300 amps on the external ammeter and check feedback voltages per Table F.5.
 - A. Pin 1 (lead 801) to Pin 6 (lead 806) should read 2.4 VDC (machine loaded to 300 amps).
9. If for any reason the machine cannot be loaded to 300 amps, Table F.5. shows what feedback voltage is produced at various current loads.
10. If the correct supply voltages are applied to the current transducer, and with the machine loaded, the feedback voltage is missing or not correct the current transducer may be faulty. Before replacing the current transducer, check the leads and plugs between the control board (J8) and the current transducer (J90). See The Wiring Diagram. For access to plug J90 and the current transducer refer to: ***Current Transducer Removal and Replacement Procedure.***
11. Remove input power to the V350-PRO.
12. Replace the control box top and any cable ties previously removed.
13. Install the case wraparound cover using the 5/16" nut driver.

V350-PRO



V350-PRO



TROUBLESHOOTING AND REPAIR

FAN CONTROL AND MOTOR TEST



WARNING

Service and repair should be performed by only Lincoln Electric factory trained personnel. Unauthorized repairs performed on this equipment may result in danger to the technician or machine operator and will invalidate your factory warranty. For your safety and to avoid electrical shock, please observe all safety notes and precautions detailed throughout this manual.

If for any reason you do not understand the test procedures or are unable to perform the test/repairs safely, contact the Lincoln Electric Service Department for electrical troubleshooting assistance before you proceed. Call 1-800-833-9353 (WELD).

DESCRIPTION

This test will help determine if the fan motor, control board, switch board, or associated leads and connectors are functioning correctly.

MATERIALS NEEDED

Voltmeter

5/16" Nut Driver

This procedure takes approximately 40 minutes to perform.

V350-PRO



TROUBLESHOOTING AND REPAIR

FAN CONTROL AND MOTOR TEST *(continued)*

TEST PROCEDURE

1. Remove the input power to the V350-PRO machine.
2. Using the 5/16" nut driver, remove the case wraparound cover.
3. Perform the **Input Filter Capacitor Discharge Procedure**.
4. Locate plug J22 on the main switch board. Do not remove the plug from the board. See Figure F.12.

FIGURE F.12 PLUG J22 LOCATION

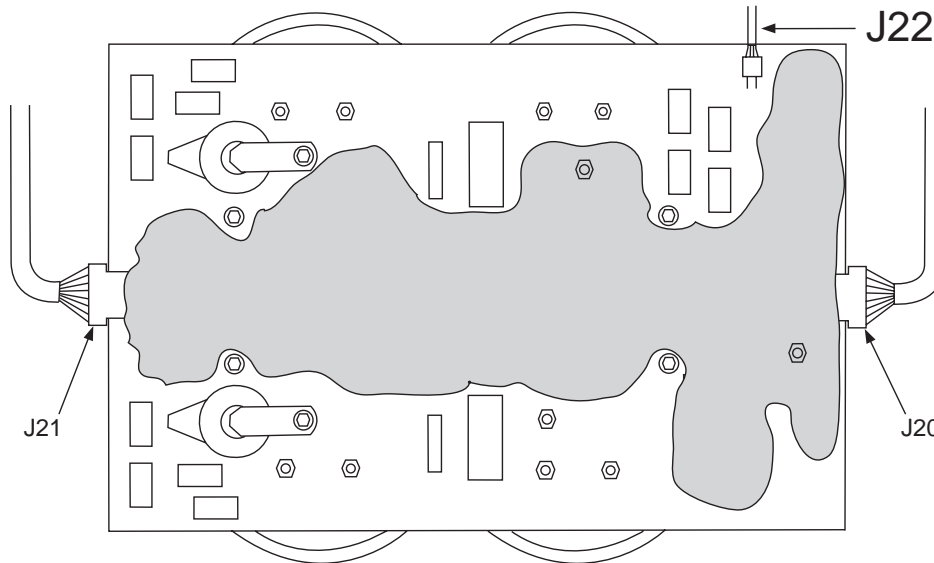

5. Carefully apply the correct input power to the machine.
6. Carefully check for 115VAC at plug J22 pin-2 to J22 pin-3. (leads 32A to 31B(C) See Figure F.13. **WARNING: HIGH VOLTAGE IS PRESENT AT THE MAIN SWITCH BOARD.**

FIGURE F.13 PLUG J22

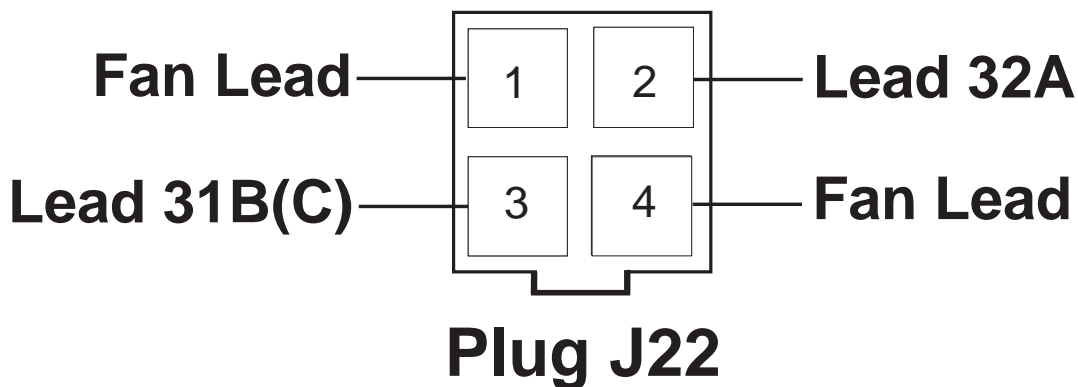

V350-PRO

LINCOLN[®]
ELECTRIC

TROUBLESHOOTING AND REPAIR

FAN CONTROL AND MOTOR TEST (continued)

7. If the 115VAC is low or not present check circuit breaker CB2 located on the front panel. If the circuit breaker is OK, perform **The Auxiliary Transformer Test**. Check plug J22, circuit breaker CB2 and associated leads for loose or faulty connections. See the Wiring Diagram.
8. Energize the weld output terminals (Select Weld Terminals ON) and carefully check for 115VAC at plug J22 pin-1 to J22 pin-4 (fan leads). **See Figure F.13**. If the 115VAC is present and the fan is not running then the fan motor may be faulty. Also check the associated leads between plug J22 and the fan motor for loose or faulty connections. See the Wiring Diagram. **WARNING: HIGH VOLTAGE IS PRESENT AT THE SWITCH BOARD.**
9. If the 115VAC is NOT present in the previous step then proceed to the fan control test.

FAN CONTROL TEST PROCEDURE

1. Locate plug J20 on the switch board. Do not remove the plug from the switch board. See **Figure F.12** and F.14.
2. Energize the weld output terminals (Select Weld Terminals ON) and carefully check for +15VDC at plug J20 pin-6+ to J20 pin-2- (leads 715 to 716). See Figure F.14. If the 15VDC is present and the fan is not running then the switch board may be faulty. If the 15VDC is not present when the weld terminals are energized then the control board may be faulty. Also check plugs J20, J7, and all associated leads for loose or faulty connections. See the Wiring Diagram.

WARNING: HIGH VOLTAGE IS PRESENT AT THE SWITCH BOARD.

3. Remove the input power to the V350-PRO.

Note: The fan motor may be accessed by the removal of the rear panel detailed in **The Current Transducer Removal and Replacement Procedure**.

4. Replace the case wrap-around cover.

FIGURE F.14 PLUG J20

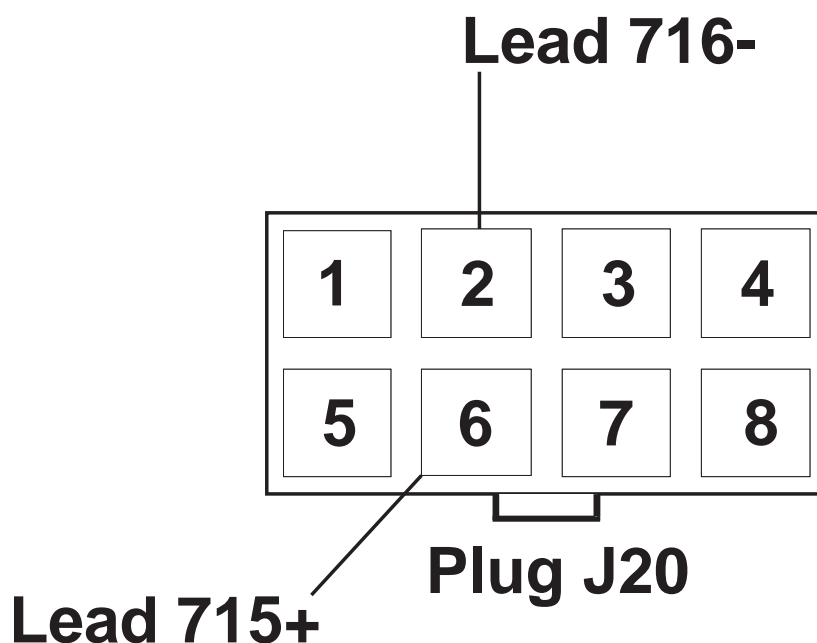

V350-PRO

LINCOLN[®]
ELECTRIC

V350-PRO



TROUBLESHOOTING AND REPAIR

SPI CABLE RESISTANCE AND VOLTAGE TEST



WARNING

Service and repair should be performed by only Lincoln Electric factory trained personnel. Unauthorized repairs performed on this equipment may result in danger to the technician or machine operator and will invalidate your factory warranty. For your safety and to avoid electrical shock, please observe all safety notes and precautions detailed throughout this manual.

If for any reason you do not understand the test procedures or are unable to perform the test/repairs safely, contact the Lincoln Electric Service Department for electrical troubleshooting assistance before you proceed. Call 1-800-833-9353 (WELD).

DESCRIPTION

This test will help determine if there is a possible “open” in the SPI cable and also determine if the correct supply voltages are being applied to the boards in the SPI network.

MATERIALS NEEDED

Volt/Ohmmeter

5/16” Nut Driver

This procedure takes approximately 35 minutes to perform.

V350-PRO



TROUBLESHOOTING AND REPAIR

SPI CABLE RESISTANCE AND VOLTAGE TEST *(continued)*

TEST PROCEDURE

1. Remove the input power to the V350-PRO.
2. Using the 5/16" nut driver, remove the case wraparound cover.
3. Perform the **Capacitor Discharge Procedure**.
4. Perform the **Display Board Removal Procedure**. Do not remove the SPI ribbon cable connecting the display board to the remote/status boards.
5. Locate and remove plug J3 from the control board. See Figure F.15.
6. Check the resistance and continuity of the SPI cable by testing with the ohmmeter from each pin on plug J3 to the corresponding pins on plug J34. See the Wiring Diagram.
7. The resistance reading pin to corresponding pin should be zero ohms or very low resistance. If the resistance reading is high or "open" check the plug connections to the SPI network PC boards. If the connections are OK and the resistance is high or "open" the SPI cable may be faulty.
8. Reconnect the plug into the control board and perform the **Display Board Replacement Procedure**.
9. With plug J3 still removed from the control board, carefully apply the correct input power to V350-PRO.
10. Turn on the machine.
11. Carefully check for the presence of +15VDC from plug J3 pin -1(+) to plug J3 pin -10(-) at the control board receptacle. See Figure F.15.
12. Carefully check for the presence of +5VDC from plug J3 pin -2(+) to plug J3 pin -10(-) at the control board receptacle. See Figure F.15.
13. If either of these voltages are low or not present, the control board may be faulty. Replace. Also Perform the **Power Board Test**.
14. Remove the input power to the V350-PRO machine.
15. Replace plug J3 into the control board.
16. Replace any cable ties previously removed.
17. Replace the case wrap-around cover.

FIGURE F.15 Plug J3

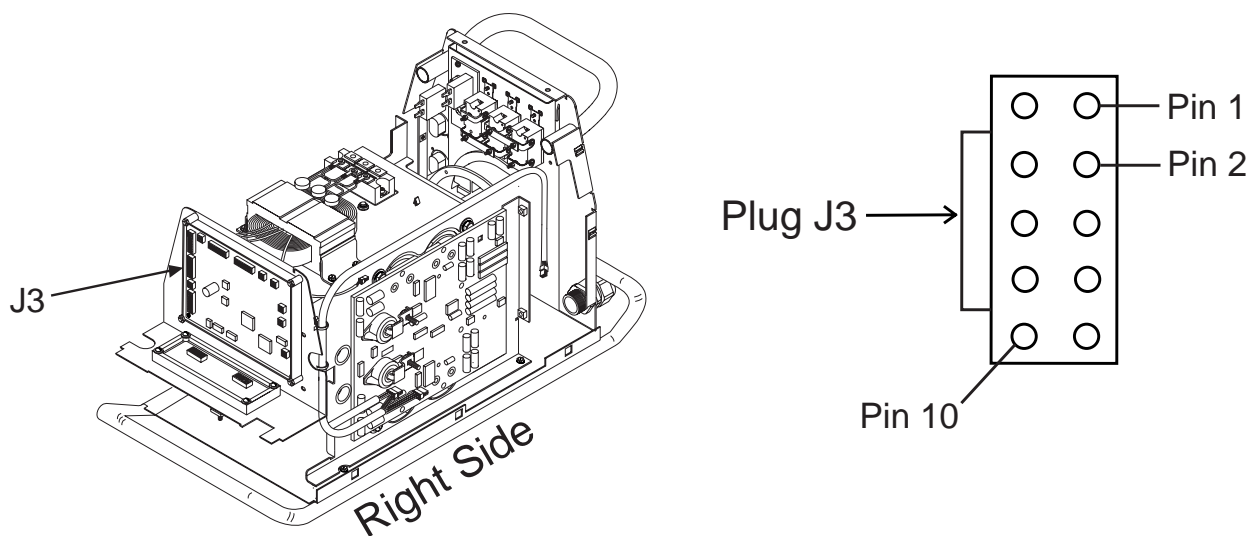

V350-PRO



TROUBLESHOOTING AND REPAIR

VOLTAGE AND CURRENT CALIBRATION PROCEDURE



WARNING

Service and repair should be performed by only Lincoln Electric factory trained personnel. Unauthorized repairs performed on this equipment may result in danger to the technician or machine operator and will invalidate your factory warranty. For your safety and to avoid electrical shock, please observe all safety notes and precautions detailed throughout this manual.

If for any reason you do not understand the test procedures or are unable to perform the test/repairs safely, contact the Lincoln Electric Service Department for electrical troubleshooting assistance before you proceed. Call 1-800-833-9353 (WELD).

DESCRIPTION

This test will help determine if the machine is capable of producing welding output and to check and adjust, if necessary, the voltage and or current calibration.

MATERIALS NEEDED

- Resistive Load Bank
- Calibrated Test Voltmeter
- Calibrated Test Ammeter

This procedure takes approximately 20 minutes to perform.

V350-PRO



TROUBLESHOOTING AND REPAIR

VOLTAGE AND CURRENT CALIBRATION PROCEDURE *(continued)*

CALIBRATION CHECK

The calibration of the V350-PRO can be checked using a resistive load bank with the V350-PRO in mode 200. Mode 200 is a constant current test mode.

1. Press and hold in the Mode Select button.
2. Turn on the V350-PRO.
3. Rotate the output knob, while still holding the mode select button in, until the displays read "mode 200". **NOTE:** Machines with an Advanced Process Panels do not have a mode select button. Use the same procedure except hold in the Memory button on the advanced process panel instead of the mode select button.
4. Release the Mode Select/Memory button and the machine will be in mode 200.
5. With the machine in mode 200 apply a resistive load to the welding output terminals (approximately .087 ohms) set the machine output to 300 amps and enable the Weld Terminals. (Weld Terminals Select ON).
6. Using the test meters note the output voltage and current.
7. The V350-PRO voltmeter must match the test meter reading to within +/- 1 volt.
8. The V350-PRO ammeter must match the test meter within +/- 5 amps.
9. If the voltmeter does not meet the specification then proceed to the **Voltage Calibration Procedure**.
10. If the ammeter does not meet the specification then proceed to the **Current Calibration Procedure**.

NOTE: Before attempting to calibrate the voltage or current setting of the V350-PRO, be sure to read the entire voltage or current calibration section. If the steps are not completed quickly, the machine will automatically leave the calibration mode without changing the calibration settings. The voltage and current calibration settings of the V350-PRO are completely independent of each other. Adjusting one will not affect the other.

VOLTAGE CALIBRATION

1. Connect the resistive load band (approximately .087 ohms) and test voltmeter to the welding output terminals.
2. Press and hold in the Mode Select/Memory button.
3. Turn on the V350-PRO.
4. Rotate the Output Control knob until the display reads "vol cAL".
5. Release the Mode Select/Memory button.
6. Adjust the output control knob until the actual output voltage reading on the test volt meter is 20volts +/- .5 volts.
7. Wait for the machine's output to be automatically turned off and then back on.
8. Adjust the Output Control knob again if necessary to make the actual voltage output 20 volts +/- .5 volts.
9. Wait for the machine's output to be automatically turned off and then back on.
10. Repeat the above two steps if necessary.
11. Press and release the Mode Select/Memory button to save the calibration.

NOTE: If the Mode Select/Memory button is not pressed within 30 seconds after adjusting the Output Control knob the machine will leave the calibration mode and use the previous calibration settings.

V350-PRO



TROUBLESHOOTING AND REPAIR

VOLTAGE AND CURRENT CALIBRATION PROCEDURE *(continued)*

CURRENT CALIBRATION PROCEDURE

1. Connect the resistive load band (approximately .087 ohms) and test ammeter to the welding output terminals.
2. Press and hold in the Mode Select/Memory button.
3. Turn on the V350-PRO.
4. Rotate the Output Control knob until the display reads "cur cAL".
5. Release the Mode Select/Memory button.
6. The left display will change to "IcAL" to indicate that current calibration is in progress.
7. The right display will scroll the following message: Adj oCP SorEAL cur-300A.
8. Adjust the Output Control knob until the actual output current reading on the test ammeter is 300amps +/-2A.
9. Wait for the machines output to be automatically turned off and then back on.
10. Adjust the Output Control knob again if necessary to make the actual output current reading on the test ammeter 300 amps +/-2A.
11. Wait for the machines output to be automatically turned off and then back on.
12. Repeat the above two steps if necessary.
13. Press and release the Mode Select/Memory button to save the calibration.
14. The left display will scroll the message IcAL SAVEd.
15. The machine will reset to normal operation.

NOTE: If the Mode Select/Memory button is not pressed within 30 seconds after adjusting the Output Control knob the machine will leave the calibration mode and use the previous calibration settings.

V350-PRO



V350-PRO



TROUBLESHOOTING & REPAIR

CONTROL BOARD REMOVAL AND REPLACEMENT



WARNING

Service and repair should be performed by only Lincoln Electric factory trained personnel. Unauthorized repairs performed on this equipment may result in danger to the technician or machine operator and will invalidate your factory warranty. For your safety and to avoid electrical shock, please observe all safety notes and precautions detailed throughout this manual.

If for any reason you do not understand the test procedures or are unable to perform the test/repairs safely, contact the Lincoln Electric Service Department for electrical troubleshooting assistance before you proceed. Call 1-800-833-9353 (WELD).

DESCRIPTION

The following procedure will aid the technician in removing the control board for maintenance or replacement.

MATERIALS NEEDED

- 5/16" Nut Driver
- 3/8" Nut Driver
- Flathead Screwdriver
- Phillips Head Screwdriver

This procedure takes approximately 30 minutes to perform.

V350-PRO



TROUBLESHOOTING & REPAIR

CONTROL BOARD REMOVAL AND REPLACEMENT (*continued*)

FIGURE F.16 - CONTROL BOARD LOCATION

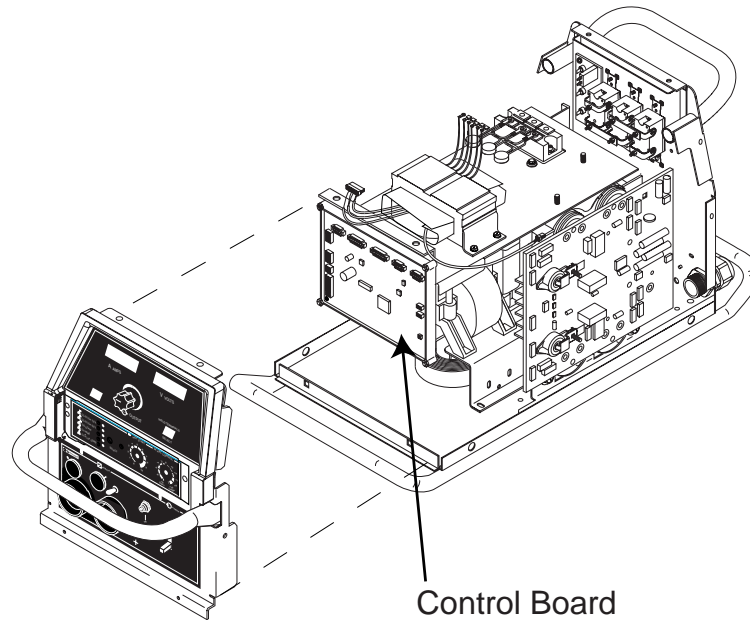

PROCEDURE

1. Remove input power to the V350-PRO.
2. Using a 5/16" nut driver remove the case wrap-around cover.
3. Perform the ***Input Filter Capacitor Discharge Procedure*** detailed earlier in this section.
4. Locate the control board behind the front panel of the machine. See Figure F.16.
5. Using a 5/16" nut driver remove the two screws from the bottom of the front of the machine. See Figure F.17.

FIGURE F.17 CASE FRONT SCREW REMOVAL

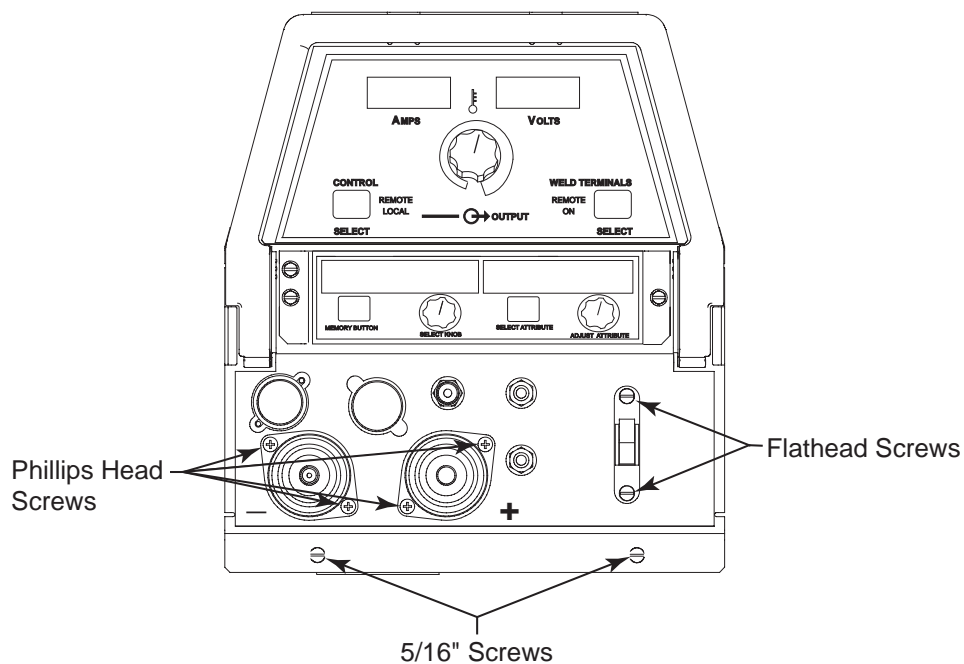

V350-PRO

LINCOLN
ELECTRIC

TROUBLESHOOTING & REPAIR

CONTROL BOARD REMOVAL AND REPLACEMENT (continued)

FIGURE F.18. - CONTROL BOARD ALL PLUG LOCATIONS

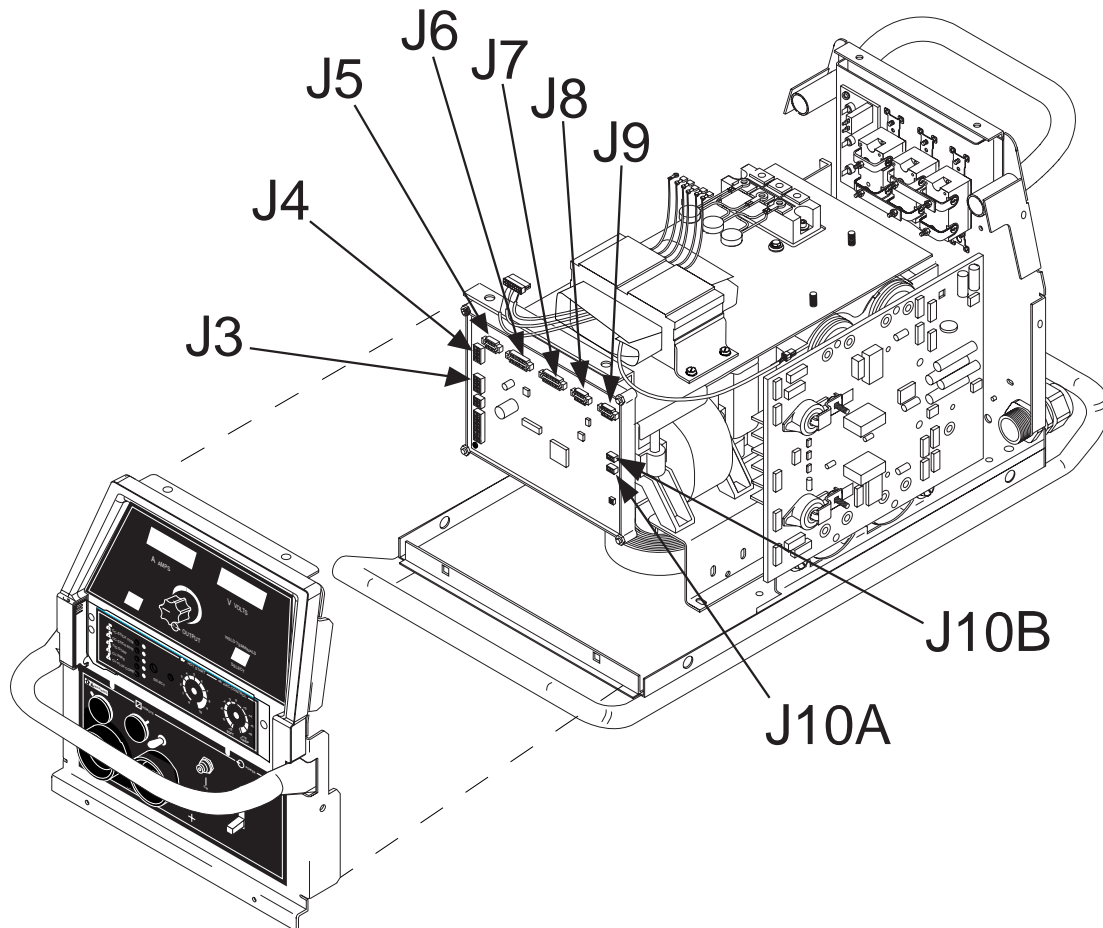

⚠ CAUTION

Observe static precautions detailed in **PC Board Troubleshooting Procedures** at the beginning of this section.

6. Using a flat head screwdriver remove the two screws and their washers from above and below the input power switch. See **Figure F.17**.
7. Using a phillips head screwdriver remove the four screws from around the two welder output terminals on the front of the machine. See **Figure F.17**.
8. The front of the machine may now gently be pulled forward to gain access to the display Board. Note: The front of the machine cannot be removed completely, only pulled forward a few inches.
9. Beginning at the right side of the control board remove plugs J10A and J10B. Note: Be sure to label each plugs position upon removal. See **Figure F.18**.
10. Working your way across the top of the board from right to left, label and remove plugs #J9, #J8, #J7, #J6, and #J5. See **Figure F.18**.
11. Working your way down the left side of the board, label and remove plugs #J4 and #J3. See **Figure F.18**.

V350-PRO

LINCOLN[®]
ELECTRIC

TROUBLESHOOTING & REPAIR

CONTROL BOARD REMOVAL AND REPLACEMENT *(continued)*

12. Using a 3/8" nut driver remove the two mounting nuts from the top two corners of the control board. See Figure F.19.
13. Cut any necessary cable ties.
14. Replace the control board.

FIGURE F.19 CONTROL BOARD MOUNTING SCREW LOCATION

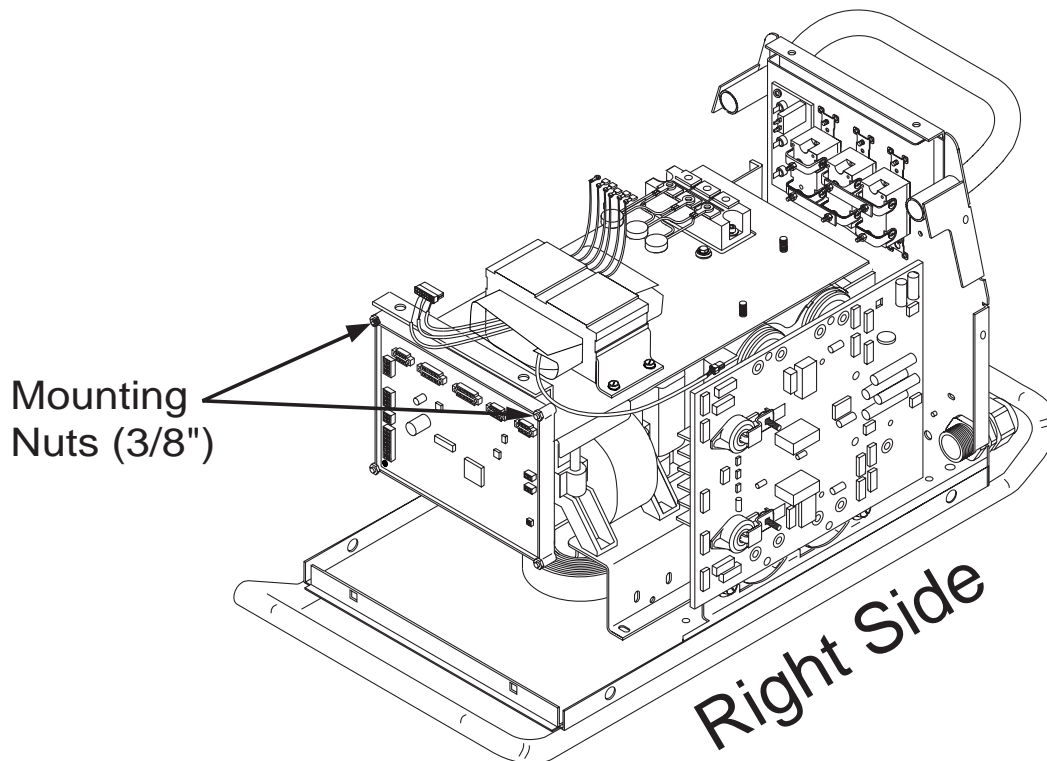

15. Replace the two 3/8" mounting nuts at the top two corners of the control board.
16. Replace any previously removed cable ties.
17. Replace plugs #J3, #J4, #J5, #J6, #J7, #J8, #J9, #J10B, and #J10A previously removed.
18. Replace the two screws and their washers from above and below the input power switch.
19. Replace the four screws from around the two welder output terminals on the front of the machine.
20. Replace the two case front mounting screws at the bottom of the front of the machine.
21. Replace the case wraparound cover.
22. Perform the **Voltage and Current Calibration Procedure**.

V350-PRO



TROUBLESHOOTING & REPAIR

DISPLAY BOARD REMOVAL AND REPLACEMENT



WARNING

Service and repair should be performed by only Lincoln Electric factory trained personnel. Unauthorized repairs performed on this equipment may result in danger to the technician or machine operator and will invalidate your factory warranty. For your safety and to avoid electrical shock, please observe all safety notes and precautions detailed throughout this manual.

If for any reason you do not understand the test procedures or are unable to perform the test/repairs safely, contact the Lincoln Electric Service Department for electrical troubleshooting assistance before you proceed. Call or 1-800-833-9353 (WELD).

DESCRIPTION

The following procedure will aid the technician in removing the display board for maintenance or replacement.

MATERIALS NEEDED

5/16" Nut Driver

Flathead Screwdriver

Phillips Head Screwdriver

This procedure takes approximately 30 minutes to perform.

V350-PRO



TROUBLESHOOTING & REPAIR

DISPLAY BOARD REMOVAL & REPLACEMENT *(continued)*

FIGURE F.20. – DISPLAY BOARD LOCATION

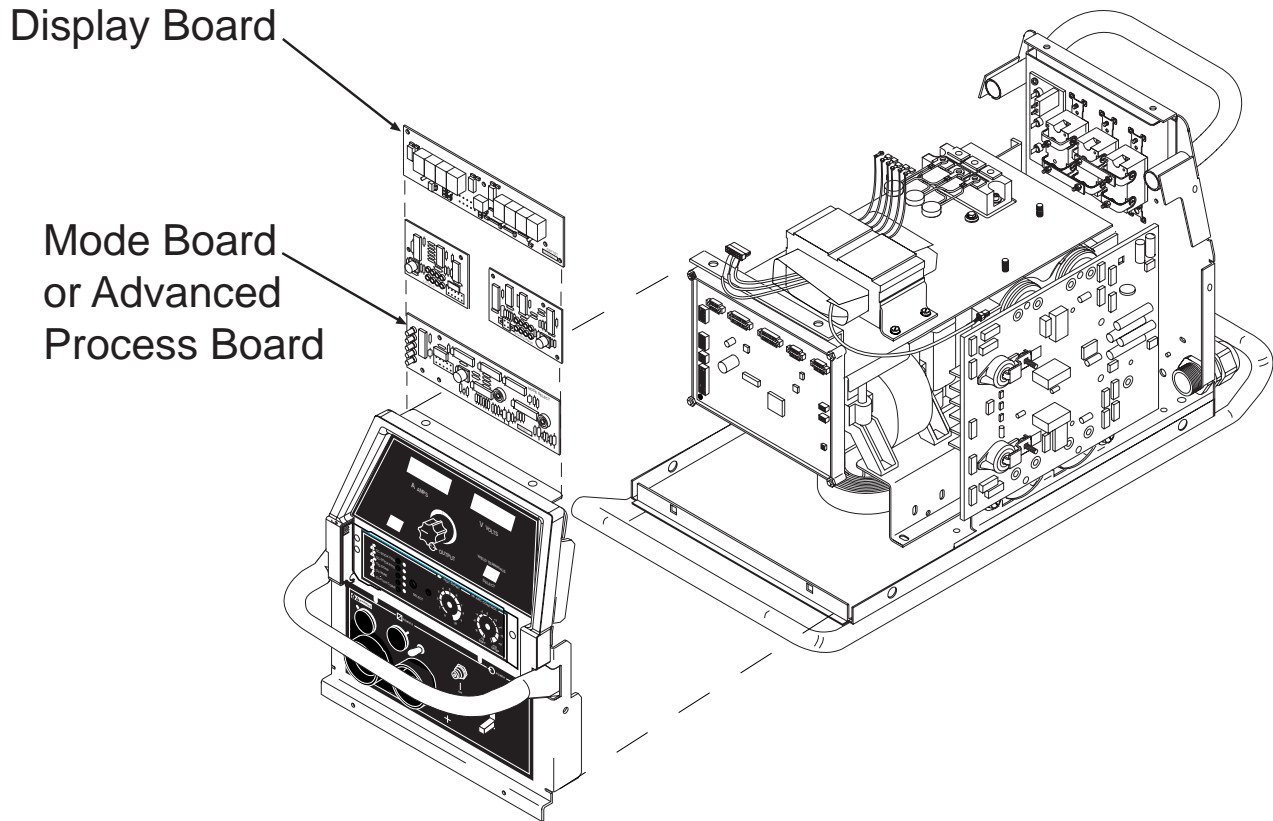

PROCEDURE

1. Remove input power to the V350-PRO.
2. Using a 5/16" nut driver remove the case wraparound cover.
3. Perform the ***Input Filter Capacitor Discharge Procedure*** detailed earlier in this section.
4. Locate the display board behind the front panel of the machine. See Figure F.20.

V350-PRO



TROUBLESHOOTING & REPAIR

DISPLAY BOARD REMOVAL & REPLACEMENT *(continued)*

FIGURE F.21. – CASE FRONT SCREW LOCATION

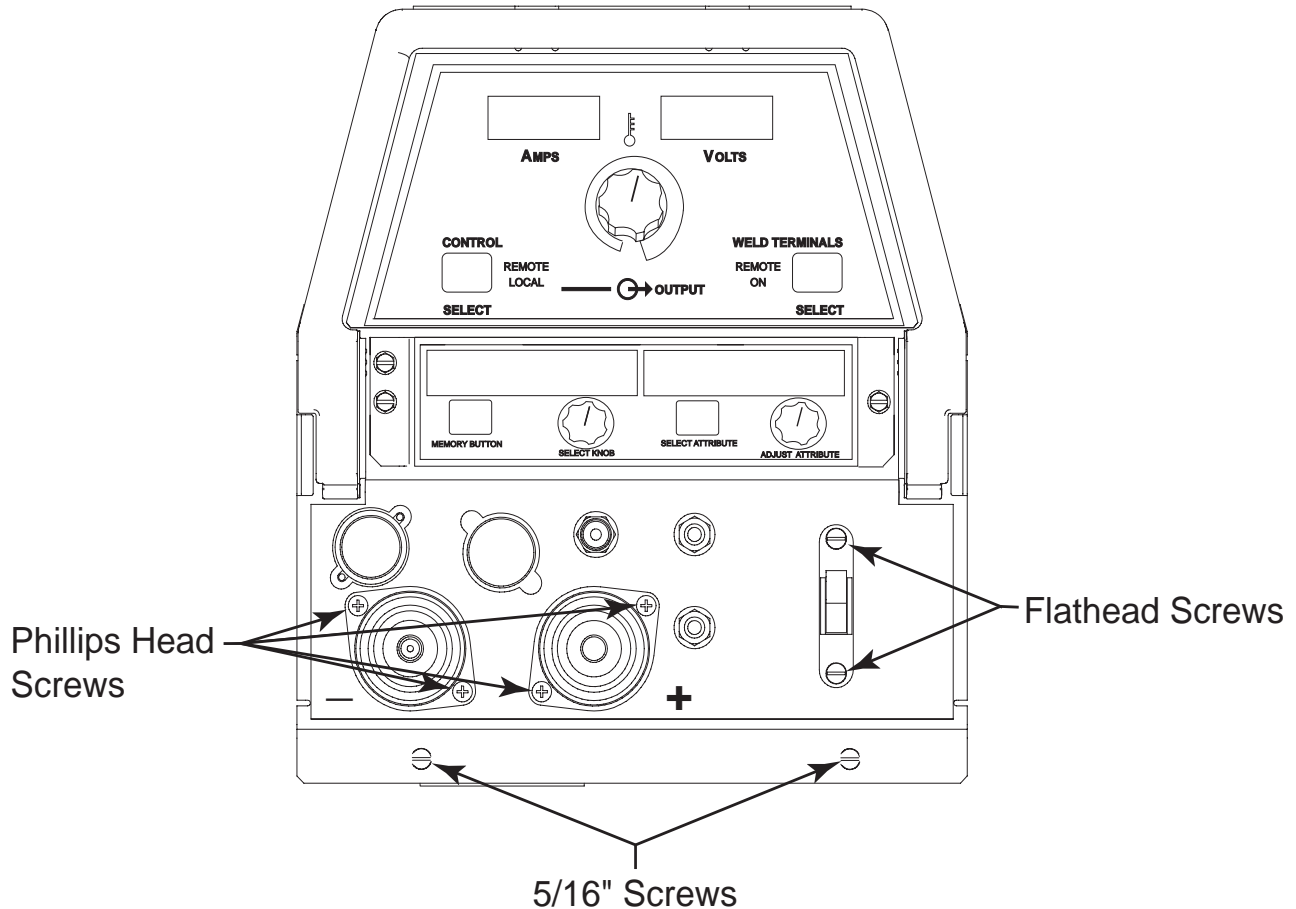

5. Using a 5/16" nut driver remove the two screws from the bottom of the front of the machine. See Figure F.21.
6. Using a flat head screwdriver remove the two screws and their washers from above and below the input power switch. See Figure F.21.
7. Using a phillips head screwdriver remove the four screws from around the two welder output terminals on the front of the machine. See Figure F.21.
8. The front of the machine may now gently be pulled forward to gain access to the display Board. Note: The front of the machine cannot be removed completely, only pulled forward a few inches.
9. The display board is now accessible to replace.

V350-PRO



TROUBLESHOOTING & REPAIR

DISPLAY BOARD REMOVAL & REPLACEMENT *(continued)*

10. Remove plug J37 from the display board. See the Wiring Diagram.
11. Remove plug J3 originating from the control board located directly across from the display board. See the Wiring Diagram.
12. Remove the display board. Note: Gentle prying from behind the board may be required.
13. Replace the display board.
14. Replace plugs #J3 and #J37 previously removed.
15. Replace the four phillips head screws removed from the front of the machine located around the two welder output terminals.
16. Replace the two flat head screws and their washers mounting the input power switch.
17. Using a 5/16" nut driver replace the two screws previously removed from the bottom front of the machine.
18. Replace the case wraparound cover.

V350-PRO



MAIN SWITCH BOARD REMOVAL AND REPLACEMENT



WARNING

Service and repair should be performed by only Lincoln Electric factory trained personnel. Unauthorized repairs performed on this equipment may result in danger to the technician or machine operator and will invalidate your factory warranty. For your safety and to avoid electrical shock, please observe all safety notes and precautions detailed throughout this manual.

If for any reason you do not understand the test procedures or are unable to perform the test/repairs safely, contact the Lincoln Electric Service Department for electrical troubleshooting assistance before you proceed. Call 1-800-833-9353 (WELD).

DESCRIPTION

The following procedure will aid the technician in removing the main switch board for maintenance or replacement.

MATERIALS NEEDED

5/16" Nut Driver

Flathead Screwdriver

7/16" mm Socket

3/16" Allen Wrench

3/8" Nut Driver

This procedure takes approximately 35 minutes to perform.

V350-PRO



MAIN SWITCH BOARD REMOVAL & REPLACEMENT (continued)

FIGURE F.22. – MAIN SWITCH BOARD LEAD LOCATIONS

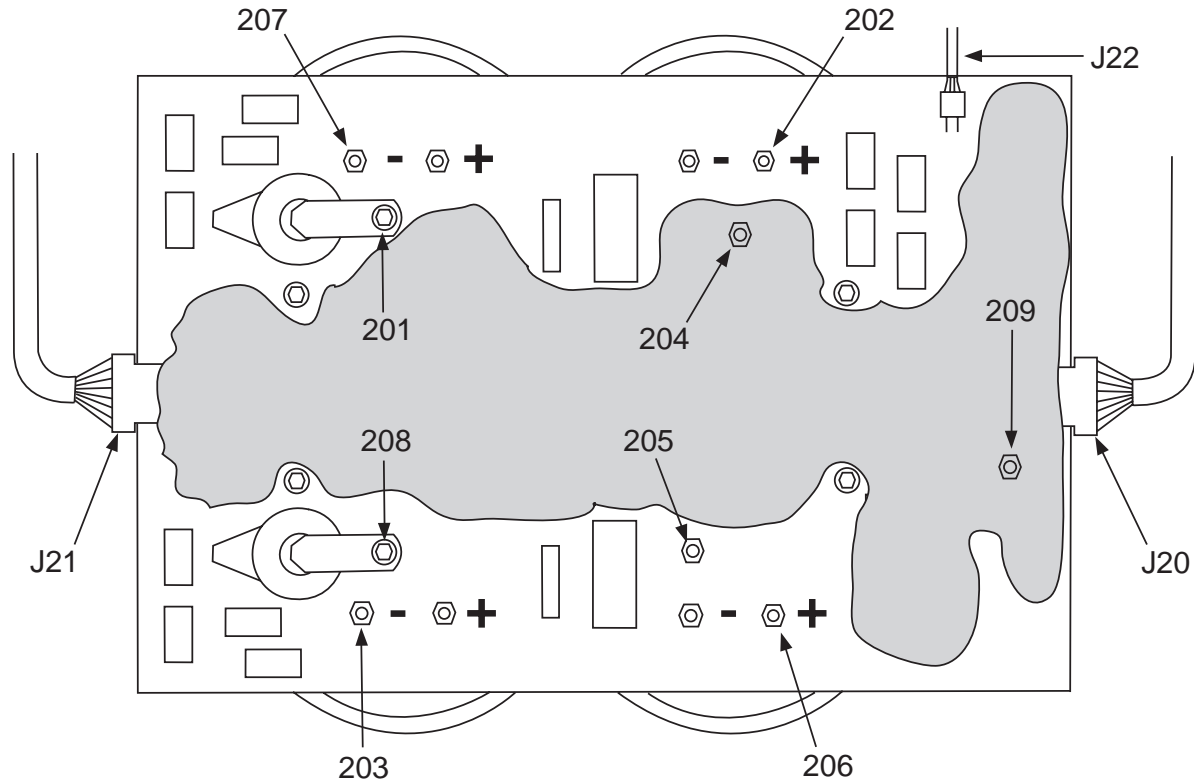

PROCEDURE

- Remove the input power to the V350-PRO.
- Using a 5/16" nut driver remove the case wrap-around cover.
- Perform the *Input Filter Capacitor Discharge Procedure* detailed earlier in this section.
- Locate the main switch board and all associated plug and lead connections. See figure F.22. See Wiring Diagram.
- Using a 5/16" and 3/8" nut driver remove the input lead shield from the area at the bottom of the main switch board.
- Using a 7/16" socket, remove leads 201, 202, 203, 204, 205, 206, 207, 208, 209 from the switch board. Note lead terminal locations and washer positions upon removal.
- Locate and disconnect the three harness plugs associated with the main switch board. Plugs #J20, #J21, #J22. See Figure F.22.
- Locate the eight capacitor terminals and remove the nuts using a 7/16" socket or nut driver. Note the position of the washers behind each nut for replacement.

CAUTION

Observe static precautions detailed in *PC Board Troubleshooting Procedures* at the beginning of this section. Failure to do so can result in permanent damage to equipment.

V350-PRO

LINCOLN[®]
ELECTRIC

MAIN SWITCH BOARD REMOVAL & REPLACEMENT *(continued)*

FIGURE F.23. – 3/16" ALLEN BOLT LOCATION

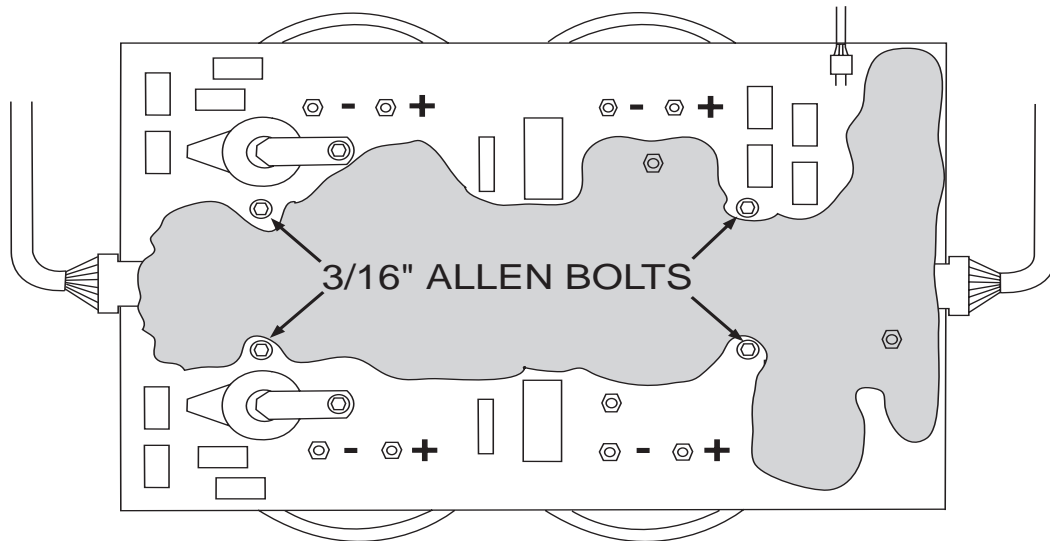

9. Using a 3/16" allen wrench remove four allen bolts and washers as shown in Figure F.23. At this point, the board is ready for removal. Carefully remove the board from the 4 nylon mounting pins. Note: Depress the retaining pins on the sides of the nylon mounts to release the board. See Figure F.24.
10. Carefully maneuver the board out of the machine.
11. Apply a thin coat of Penetrox A-13 to the IGBT heatsinks on the back of the new switch boards mating surfaces. Note: Keep compound away from the mounting holes.
12. Mount the new board on the nylon mounting pins.
13. Replace the four allen bolts and washers previously removed.
14. Replace the eight capacitor terminal nuts, washers, and necessary leads previously removed.
15. Reconnect the three harness plugs previously removed.
16. Reconnect the nine leads (#201-#209) that were previously removed.
17. Pre-torque all screws to 25 inch lbs. before tightening to 44 inch lbs.
18. Replace the case wraparound cover.

FIGURE F.24. – NYLON MOUNTING PIN

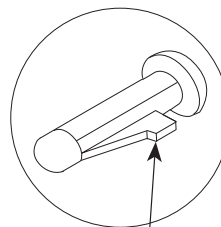

DEPRESS
LOCKING TAB ON
MOUNTING PIN

V350-PRO

LINCOLN[®]
ELECTRIC

V350-PRO



TROUBLESHOOTING & REPAIR

ADVANCED PROCESS PANEL REMOVAL AND REPLACEMENT



WARNING

Service and repair should be performed by only Lincoln Electric factory trained personnel. Unauthorized repairs performed on this equipment may result in danger to the technician or machine operator and will invalidate your factory warranty. For your safety and to avoid electrical shock, please observe all safety notes and precautions detailed throughout this manual.

If for any reason you do not understand the test procedures or are unable to perform the test/repairs safely, contact the Lincoln Electric Service Department for electrical troubleshooting assistance before you proceed. Call 1-800-833-9353 (WELD).

DESCRIPTION

The following procedure will aid the technician in removing the mode board for maintenance or replacement.

MATERIALS NEEDED

- 5/16" Nut Driver
- Small Flathead Screwdriver
- Flathead Screwdriver
- Small Phillips Head Screwdriver
- Phillips Head Screwdriver
- 9/16" Wrench

This procedure takes approximately 40 minutes to perform.

V350-PRO



TROUBLESHOOTING & REPAIR

ADVANCED PROCESS PANEL REMOVAL AND REPLACEMENT *(continued)*

FIGURE F.25. – MODE BOARD LOCATION

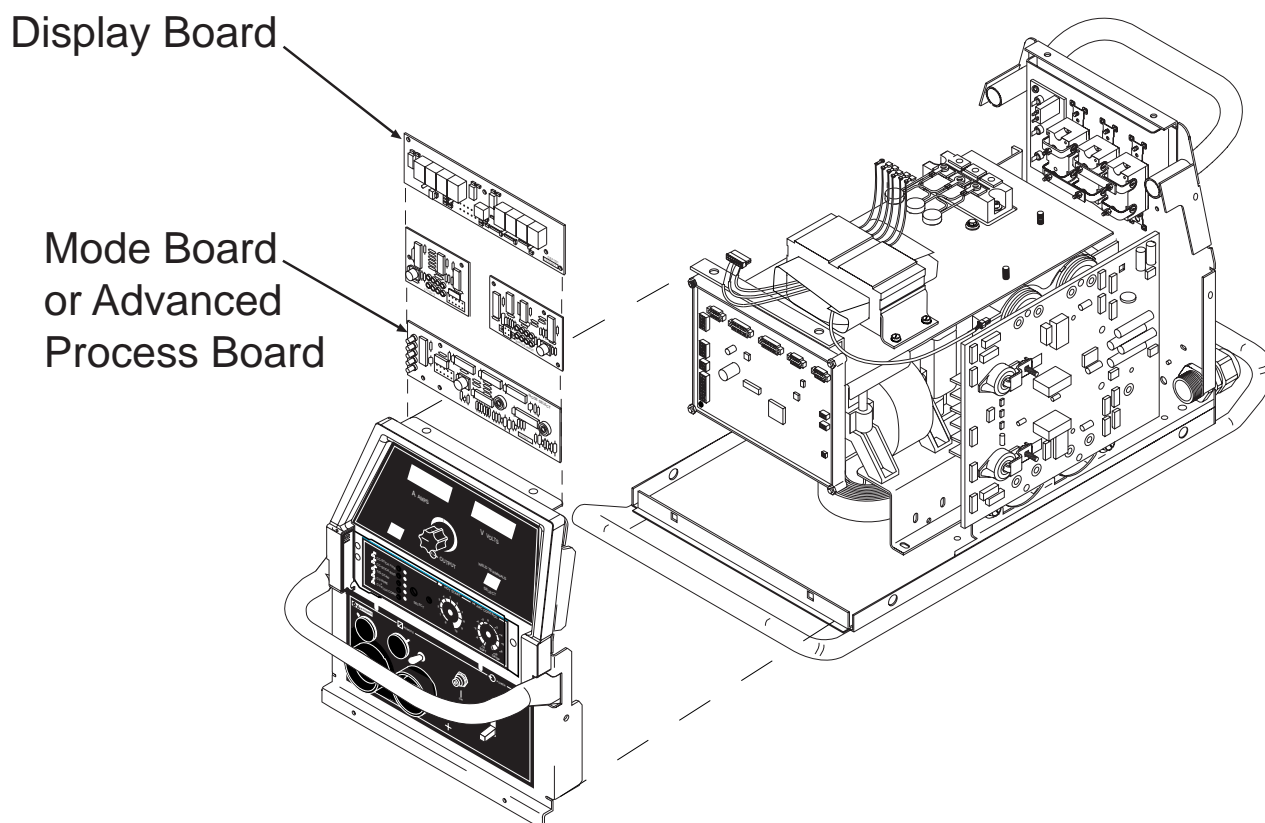

PROCEDURE

1. Remove input power to the V350-PRO.
2. Using a 5/16" nut driver remove the case wraparound cover.
3. Perform the **Input Filter Capacitor Discharge Procedure** detailed earlier in this section.
4. Locate the advanced process board behind the front panel of the machine. See Figure F.25.

V350-PRO



TROUBLESHOOTING & REPAIR

ADVANCED PROCESS PANEL REMOVAL AND REPLACEMENT *(continued)*

FIGURE F.26. – CASE FRONT SCREW REMOVAL

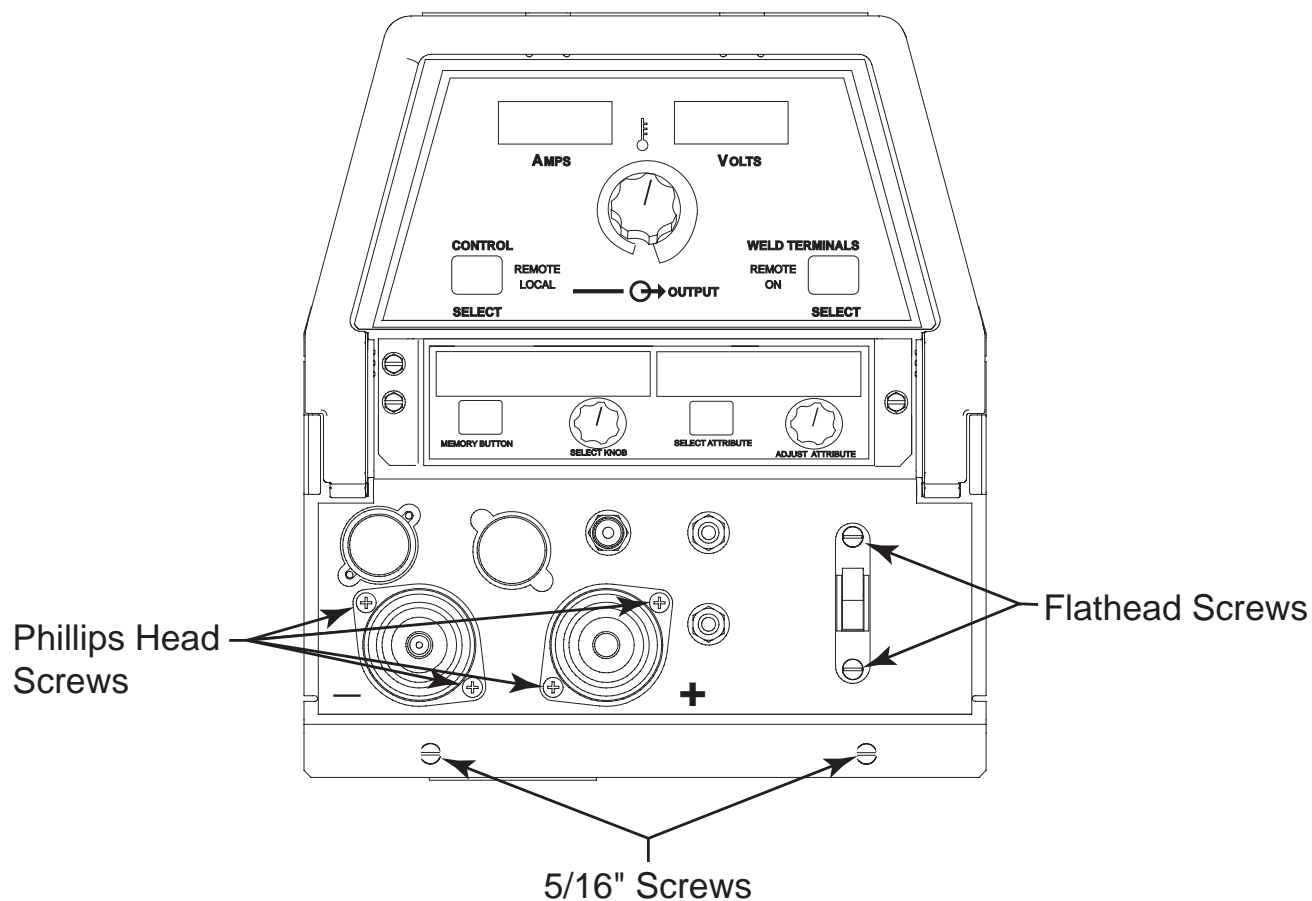

5. Using a 5/16" nut driver remove the two screws from the bottom of the front of the machine. See Figure F.26.
6. Using a flat head screwdriver remove the two screws and their washers from above and below the input power switch. See Figure F.26..
7. Using a phillips head screwdriver remove the four screws from around the two welder output terminals on the front of the machine. See Figure F.26.
8. The front of the machine may now gently be pulled forward to gain access to the mode board. Note: The front of the machine cannot be removed completely, only pulled forward a few inches.

V350-PRO

LINCOLN[®]
ELECTRIC

TROUBLESHOOTING & REPAIR

ADVANCED PROCESS PANEL REMOVAL AND REPLACEMENT *(continued)*

FIGURE F.27.. – CASE FRONT

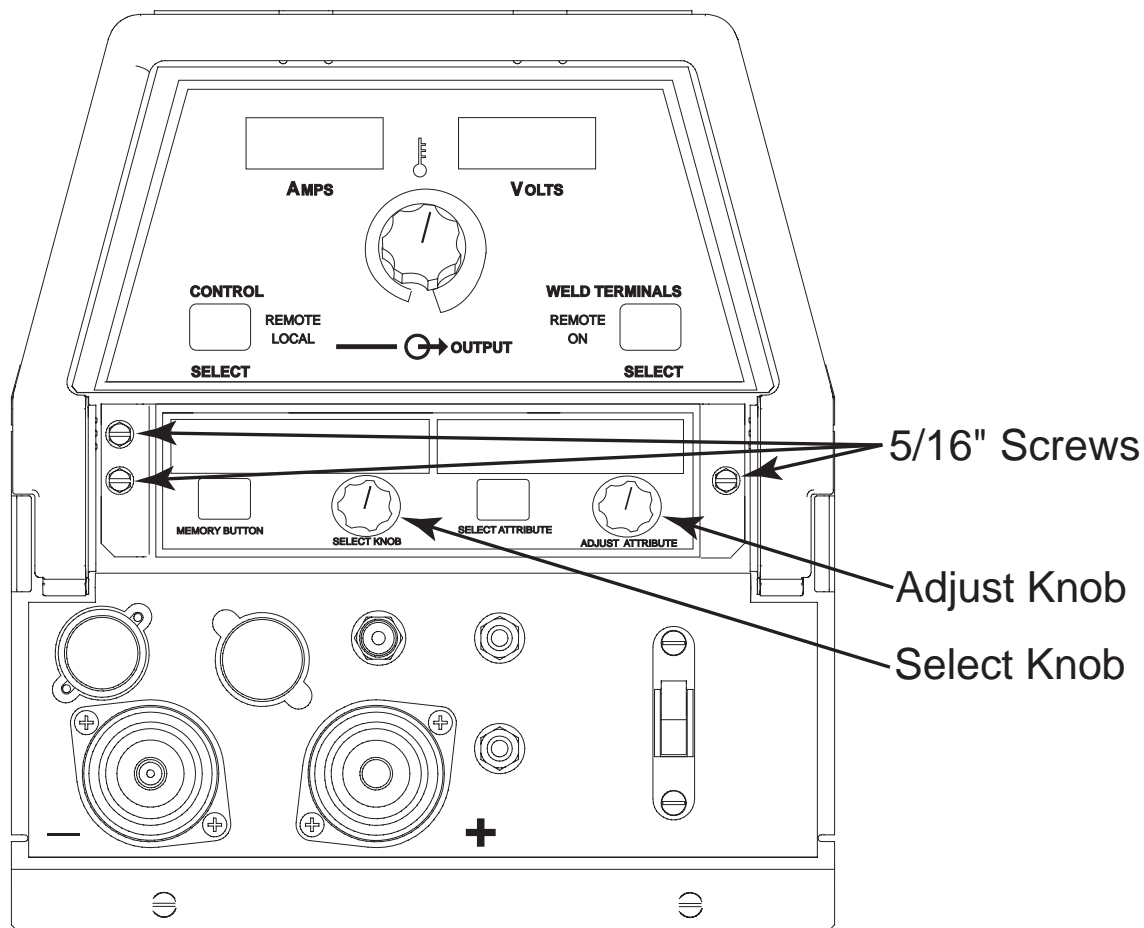

9. Remove plug #J33 from the remote board. See the Wiring Diagram.
10. Open the cover of the weld mode display on the front of the machine.
11. Using a 5/16" nut driver, remove the three 5/16" screws as shown in Figure F.27.
12. Place both knobs in the six o'clock position.
13. Using a small flathead screwdriver, loosen the screw in the "Select" knob and the "Adjust" knob. The knobs should slide off of their shafts. **See Figure F.28.**
14. Using a 9/16" wrench remove the nuts and their washers behind the two knobs previously removed.
15. Perform the **Remote Board Removal Procedure. (Start at step #10)**
16. Using a phillips head screwdriver remove the two phillips head mounting screws at the bottom of the Advanced Process board.
17. Remove the Advanced Process board.

V350-PRO

LINCOLN[®]
ELECTRIC

TROUBLESHOOTING & REPAIR

ADVANCED PROCESS PANEL REMOVAL AND REPLACEMENT *(continued)*

FIGURE F.28. – SCREW IN CAP

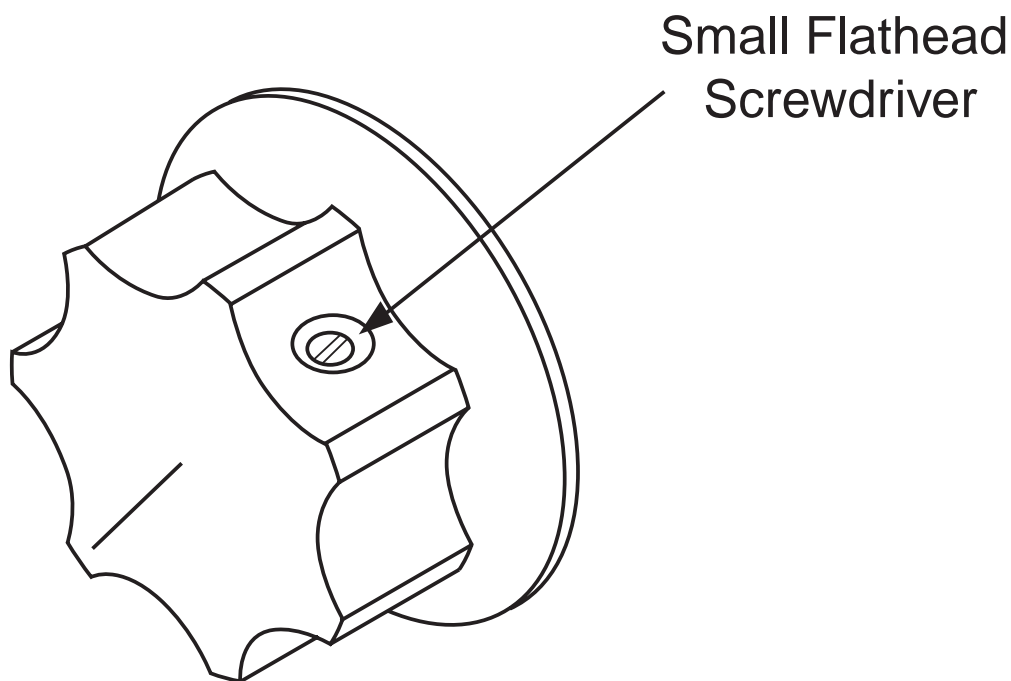

18. Replace the Advanced Process board.
19. Replace the two phillips head screws at the bottom of the advanced process board.
20. Perform the **Remote Board Replacement Procedure**.
21. Replace the 9/16" nuts and their washers behind the "Adjust" and "Select" knobs.
22. Using a small screwdriver replace the two knobs previously removed.
23. Replace the three 5/16" screws previously removed from the front of the machine located around the Advanced Process board.
24. Reconnect plug #J33 previously removed.
25. Replace the four phillips head screws removed from the front of the machine located around the two welder output terminals.
26. Replace the two flat head screws and their washers from around the input power switch.
27. Using a 5/16" nut driver replace the two screws previously removed from the bottom front of the machine
28. Replace the case wraparound cover.

V350-PRO

LINCOLN[®]
ELECTRIC

V350-PRO



TROUBLESHOOTING & REPAIR

REMOTE BOARD REMOVAL AND REPLACEMENT



WARNING

Service and repair should be performed by only Lincoln Electric factory trained personnel. Unauthorized repairs performed on this equipment may result in danger to the technician or machine operator and will invalidate your factory warranty. For your safety and to avoid electrical shock, please observe all safety notes and precautions detailed throughout this manual.

If for any reason you do not understand the test procedures or are unable to perform the test/repairs safely, contact the Lincoln Electric Service Department for electrical troubleshooting assistance before you proceed. Call 1-800-833-9353 (WELD).

DESCRIPTION

The following procedure will aid the technician in removing the status board for maintenance or replacement.

MATERIALS NEEDED

- 5/16" Nut Driver
- Flathead Screwdriver
- Phillips Head Screwdriver

This procedure takes approximately 30 minutes to perform.

V350-PRO



REMOTE BOARD REMOVAL AND REPLACEMENT *(continued)*

PROCEDURE

1. Remove input power to the V350-PRO.
2. Using a 5/16" nut driver remove the case wrap-around cover.
3. Perform the ***Input Filter Capacitor Discharge Procedure*** detailed earlier in this section.
4. Locate the remote board behind the front panel of the machine. See Figure F.29.

FIGURE F.29. – REMOTE BOARD LOCATION

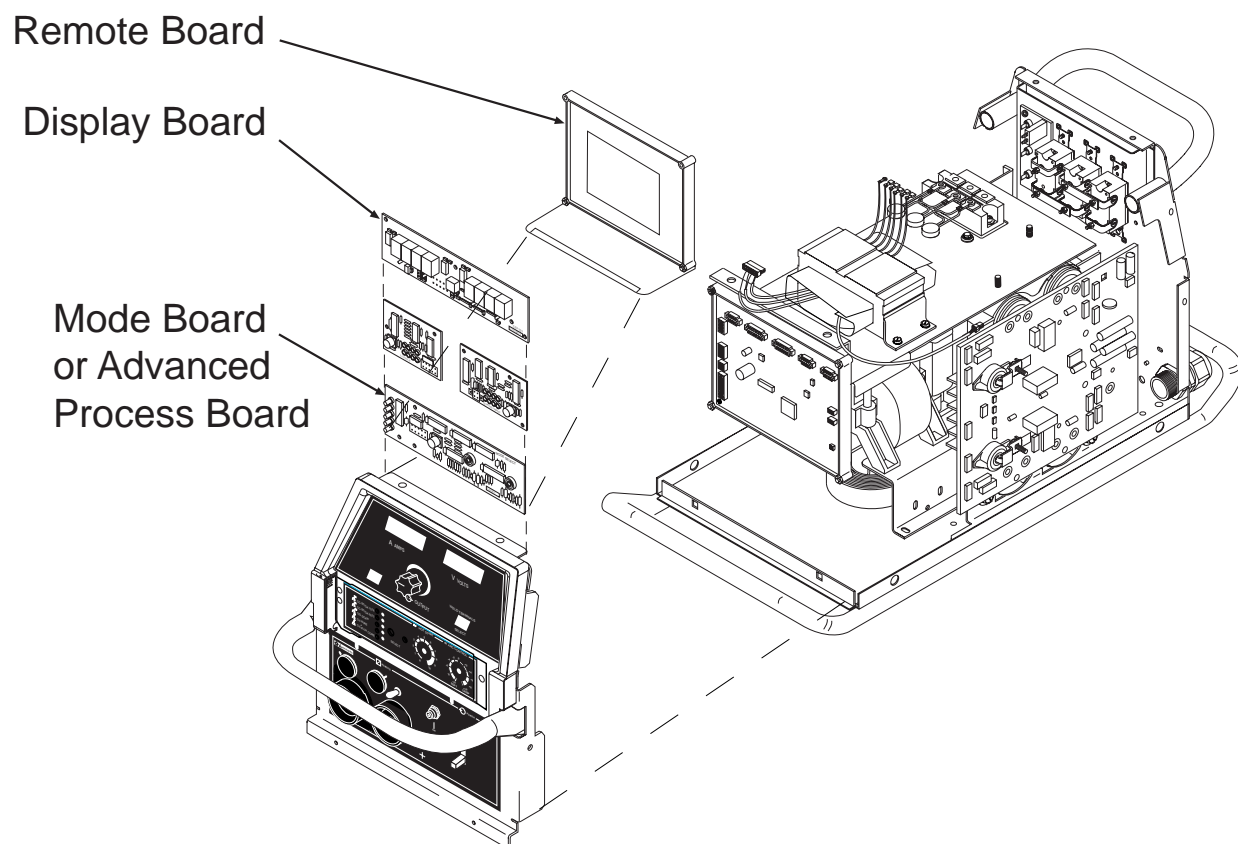

V350-PRO

LINCOLN[®]
ELECTRIC

TROUBLESHOOTING & REPAIR

REMOTE BOARD REMOVAL AND REPLACEMENT *(continued)*

5. Using a 5/16" nut driver remove the two screws from the bottom front of the machine. See Figure F.30.
6. Using a flat head screwdriver remove the two screws and their washers from around the input power switch. See Figure F.30.
7. Using a phillips head screwdriver remove the four screws from around the two welder output terminals on the front of the machine. See Figure F.30.
8. The front of the machine may now gently be pulled forward to gain access to the remote Board.
Note: The front of the machine cannot be removed completely, only pulled forward a few inches.
9. The remote board is now accessible to replace.

FIGURE F.30. - FRONT SCREW REMOVAL

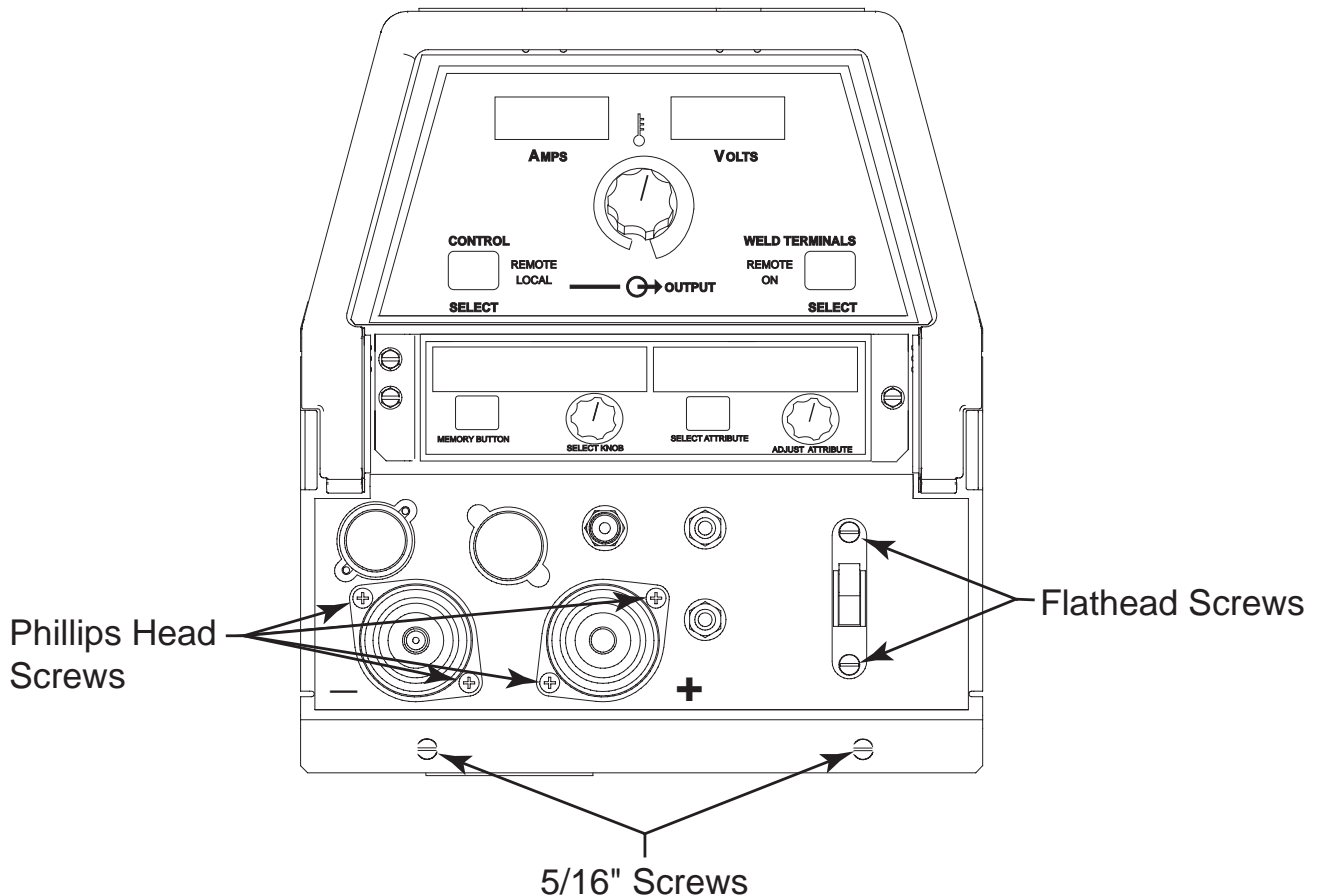

V350-PRO

LINCOLN[®]
ELECTRIC

TROUBLESHOOTING & REPAIR

REMOTE BOARD REMOVAL AND REPLACEMENT *(continued)*

10. Remove plug J37 from the display board. See Wiring Diagram.
11. Remove plugs J33, J333 and J331 from the remote board.
12. Using a flat head screwdriver, remove the two mounting screws and washers from the bottom of the remote board. See Figure F.31.
13. Remove the remote board.
14. Replace the remote board.
15. Replace the two flat head mounting screws and washers previously removed from the bottom of the remote board.
16. Replace plugs J331, J333, J33 and previously removed from the remote board.
17. Replace plug J37 previously removed from the display board.
18. Replace the four phillips head screws removed from the front of the machine located around the two welder output terminals.
19. Replace the two flat head screws and their washers from around the input power switch.
20. Using a 5/16" nut driver replace the two screws previously removed from the bottom front of the machine
21. Replace the case wraparound cover.

FIGURE F.31. – REMOTE BOARD (PLUG LOCATION)

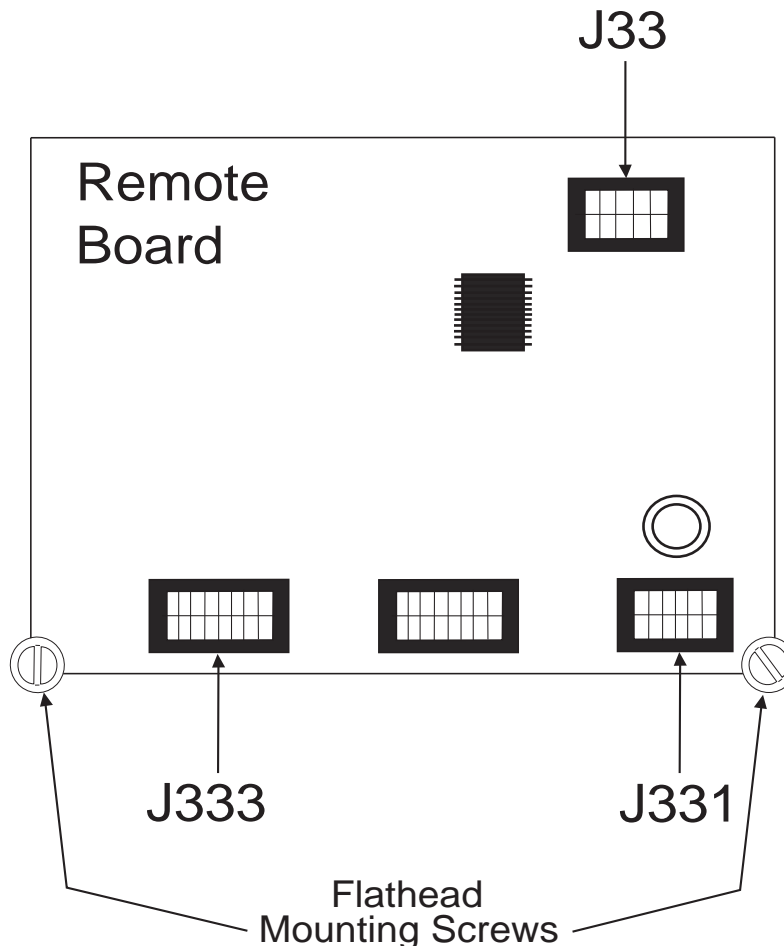

V350-PRO

LINCOLN[®]
ELECTRIC

TROUBLESHOOTING & REPAIR

SNUBBER BOARD REMOVAL AND REPLACEMENT



WARNING

Service and repair should be performed by only Lincoln Electric factory trained personnel. Unauthorized repairs performed on this equipment may result in danger to the technician or machine operator and will invalidate your factory warranty. For your safety and to avoid electrical shock, please observe all safety notes and precautions detailed throughout this manual.

If for any reason you do not understand the test procedures or are unable to perform the test/repairs safely, contact the Lincoln Electric Service Department for electrical troubleshooting assistance before you proceed. Call 1-800-833-9353 (WELD).

DESCRIPTION

The following procedure will aid the technician in removing the snubber board for maintenance or replacement.

MATERIALS NEEDED

5/16" Nut Driver

7/16 Socket or Nut Driver

This procedure takes approximately 15 minutes to perform.

V350-PRO



SNUBBER BOARD REMOVAL AND REPLACEMENT (continued)

PROCEDURE

1. Remove input power to the V350-PRO.
2. Using a 5/16" nut driver remove the case wrap-around cover.
3. Perform the **Input Filter Capacitor Discharge Procedure** detailed earlier in this section.
4. Locate the snubber board.. See Figure F.32.

FIGURE F.32. – SNUBBER BOARD LOCATION

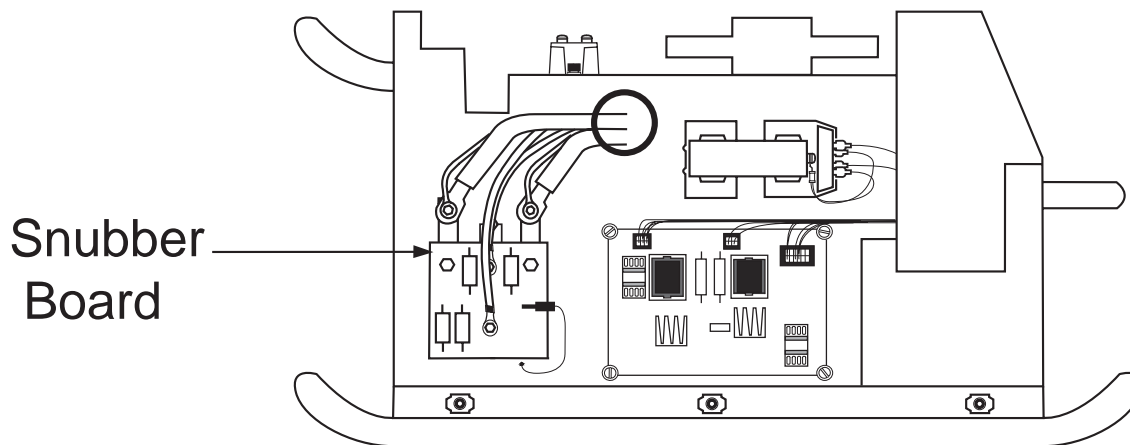

LEFT SIDE

5. Remove small lead #B1 from the board. See Figure F.33.
6. Remove the four bolts using a 7/16" socket. Two of these bolts have leads #30 and #10 connected to them. Note the position of all leads and associated washers upon removal.
7. Carefully remove the snubber board.
8. Replace the snubber board.
9. Replace the bolts, leads, and washers previously removed. Torque bolt to 30-40 Inch Lbs.
10. Replace the case wraparound cover.

FIGURE F.33. – SNUBBER BOARD LEADS (CLOSE UP)

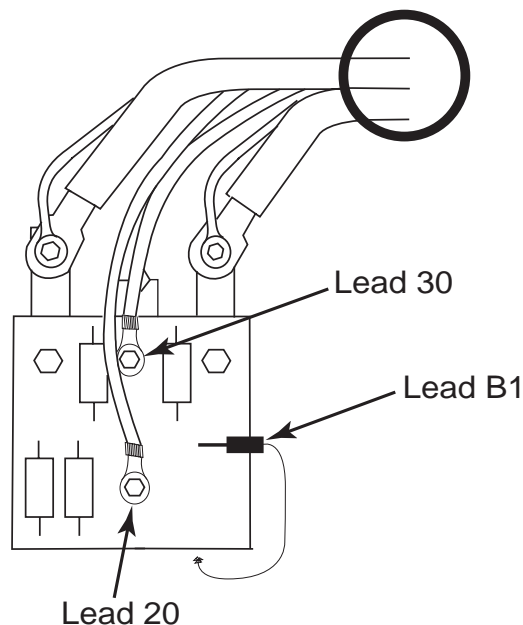

V350-PRO

LINCOLN[®]
ELECTRIC

TROUBLESHOOTING & REPAIR

POWER BOARD REMOVAL AND REPLACEMENT



WARNING

Service and repair should be performed by only Lincoln Electric factory trained personnel. Unauthorized repairs performed on this equipment may result in danger to the technician or machine operator and will invalidate your factory warranty. For your safety and to avoid electrical shock, please observe all safety notes and precautions detailed throughout this manual.

If for any reason you do not understand the test procedures or are unable to perform the test/repairs safely, contact the Lincoln Electric Service Department for electrical troubleshooting assistance before you proceed. Call 1-800-833-9353 (WELD).

DESCRIPTION

The following procedure will aid the technician in removing the power board for maintenance or replacement.

MATERIALS NEEDED

5/16" Nut Driver

3/8" Nut Driver

This procedure takes approximately 20 minutes to perform.

V350-PRO



POWER BOARD REMOVAL AND REPLACEMENT *(continued)*

FIGURE F.34. POWER BOARD LOCATION

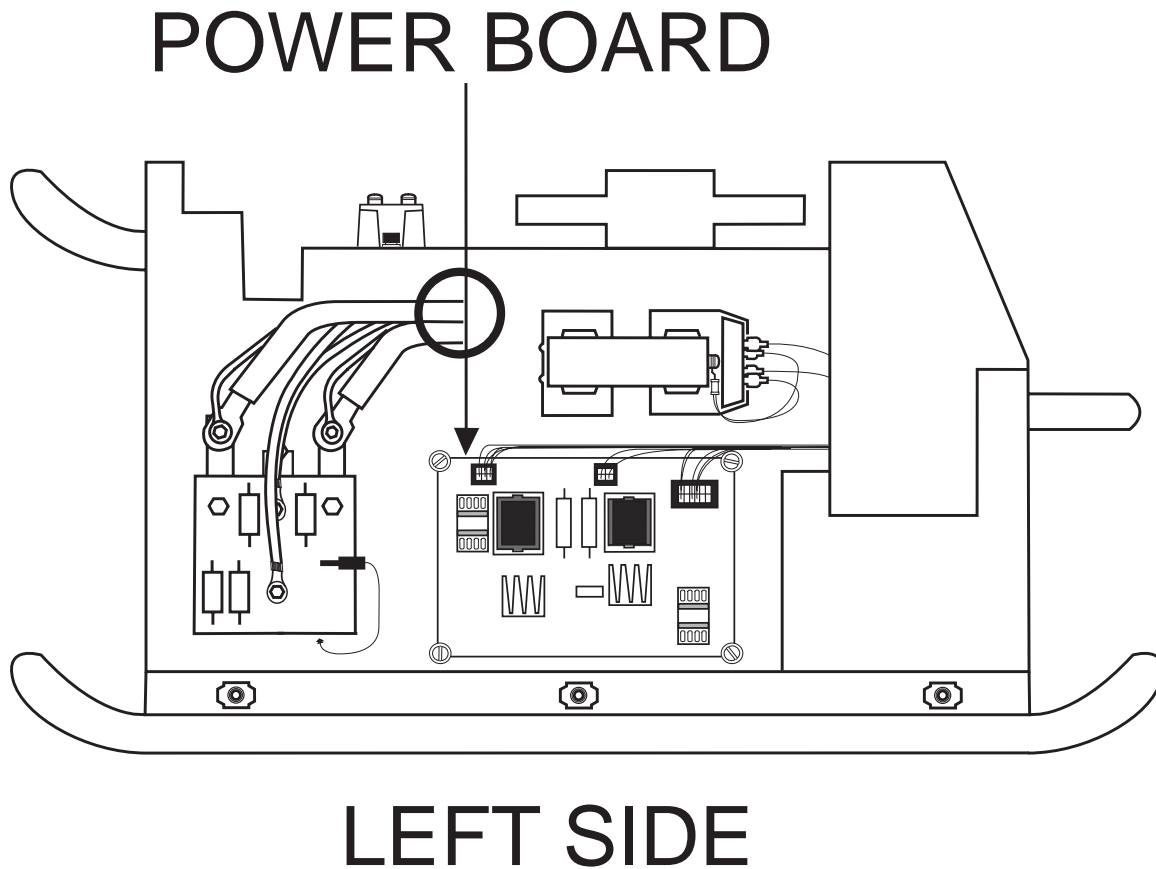
**PROCEDURE**

1. Remove input power to the V350-PRO.
2. Using a 5/16" nut driver remove the case wrap-around cover.
3. Perform the ***Input Filter Capacitor Discharge Procedure*** detailed earlier in this section.
4. Locate the power board. See Figure F.34.

V350-PRO

LINCOLN[®]
ELECTRIC

TROUBLESHOOTING & REPAIR

POWER BOARD REMOVAL AND REPLACEMENT *(continued)*

5. Locate the three plug connections. J41, J42 and J43. See figure F.35.
6. Carefully remove the three plugs from the power board.
7. Remove the three nuts and at the corners of the board using a 3/8" nut driver. Board is ready for removal.
8. Remove the power board.
9. Replace with new power board.
10. Secure the new power board into its proper position with the three 3/8" nuts previously removed.
11. Replace the three plugs previously removed. Plugs J41, J42 and J43.
12. Replace the case wraparound cover.

FIGURE F.35. – POWER BOARD LEAD LOCATION

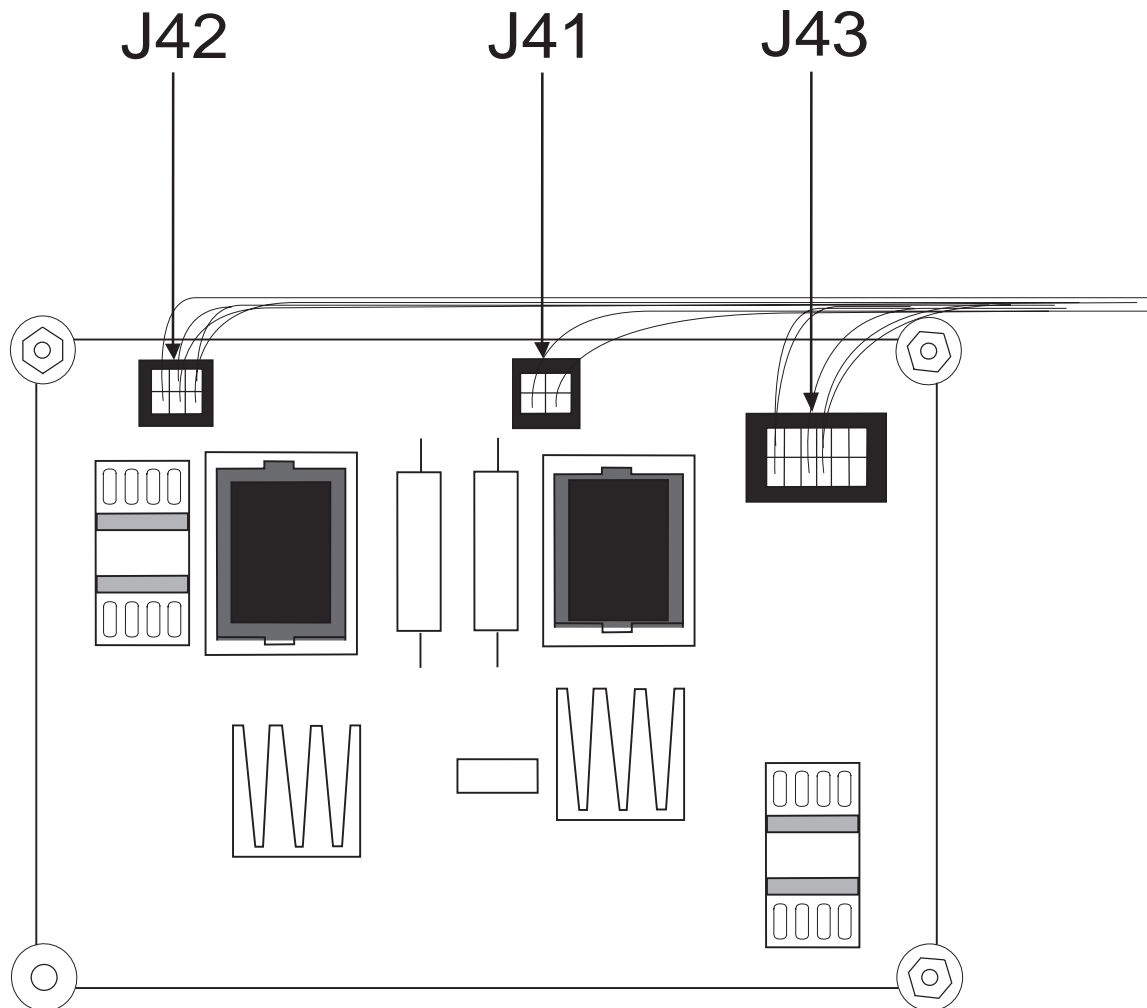

V350-PRO

LINCOLN[®]
ELECTRIC

V350-PRO



TROUBLESHOOTING & REPAIR

INPUT RECTIFIER REMOVAL AND REPLACEMENT



WARNING

Service and repair should be performed by only Lincoln Electric factory trained personnel. Unauthorized repairs performed on this equipment may result in danger to the technician or machine operator and will invalidate your factory warranty. For your safety and to avoid electrical shock, please observe all safety notes and precautions detailed throughout this manual.

If for any reason you do not understand the test procedures or are unable to perform the test/repairs safely, contact the Lincoln Electric Service Department for electrical troubleshooting assistance before you proceed. Call 1-800-833-9353 (WELD).

DESCRIPTION

The following procedure will aid the technician in removing the input rectifier for maintenance or replacement.

MATERIALS NEEDED

3/16" Allen wrench
5/16" Nut Driver
Flathead Screwdriver
Penetrox A-13 Heatsink Compound
Silicon Sealant

This procedure takes approximately 30 minutes to perform.

V350-PRO



TROUBLESHOOTING & REPAIR

INPUT RECTIFIER REMOVAL AND REPLACEMENT *(continued)*

PROCEDURE

1. Remove input power to the V350-PRO.
2. Using a 5/16" nut driver remove the case wraparound cover.
3. Perform the **Input Filter Capacitor Discharge Procedure** detailed earlier in this section.
4. Locate the input rectifier. See figure F.36.
5. Carefully remove the silicon sealant insulating the six input rectifier terminals.
6. Remove the six screws from the terminals using a flathead screwdriver. Carefully note the position of all leads and their positions upon removal. **See Figure F.37.**
7. Using a 3/16" in. allen wrench remove the two mounting screws and washers from the input bridge. **See Figure F.37.**
8. Remove the input bridge.

FIGURE F.36. – INPUT RECTIFIER LOCATION

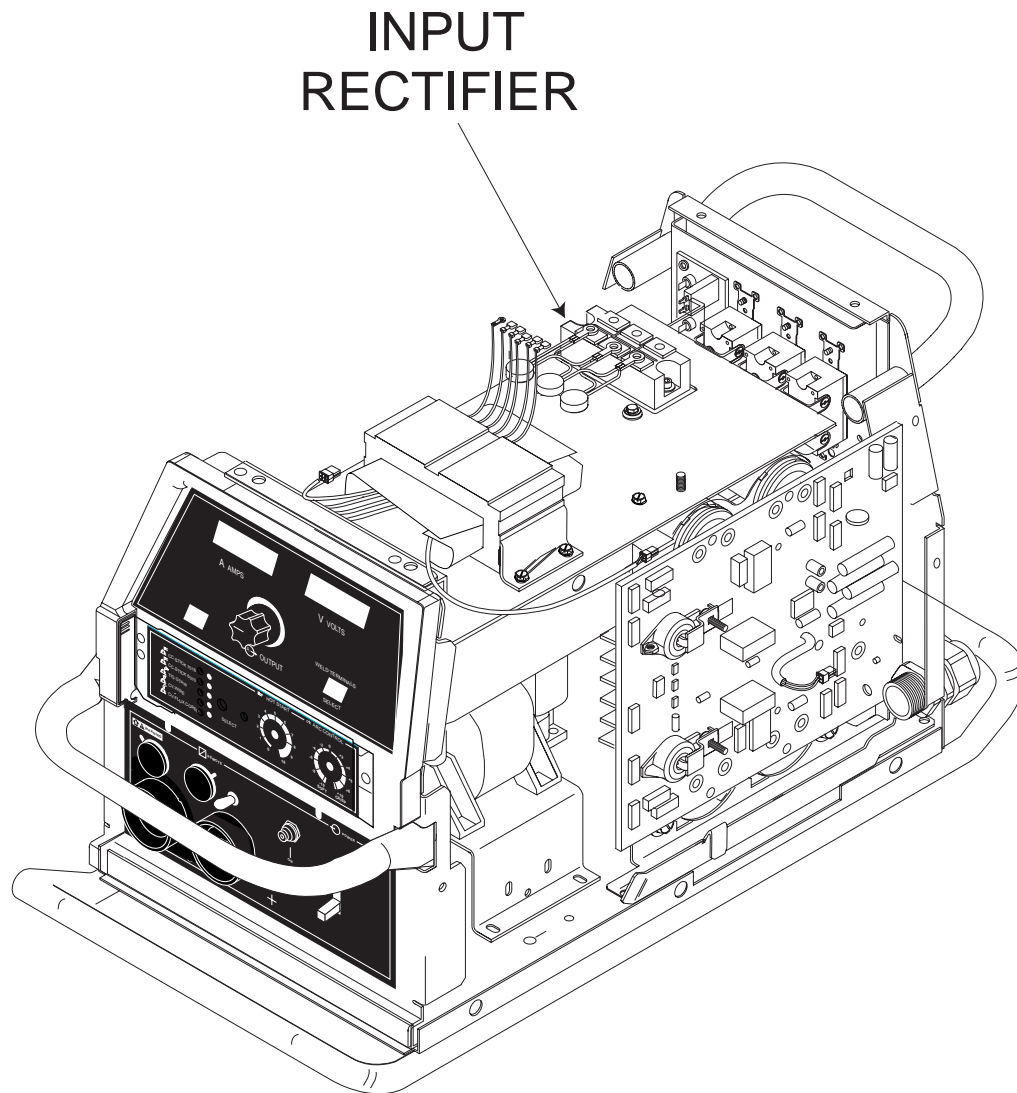

V350-PRO

LINCOLN[®]
ELECTRIC

TROUBLESHOOTING & REPAIR

INPUT RECTIFIER REMOVAL AND REPLACEMENT *(continued)*

9. Apply a thin coat of Penetrox A-13 heatsink compound to the point of contact between the input rectifier and the mounting surface.
10. Secure the new input bridge into its proper position with the two 3/16" in. allen mounting screws previously removed. Torque to 44 inch pounds.
11. Reconnect the previously removed leads to their proper locations. Torque to 31 inch pounds.
12. Cover the input rectifier and its six terminals with silicon sealant.
13. Replace the case wraparound cover.

FIGURE F.37. - INPUT RECTIFIER (CLOSE-UP)

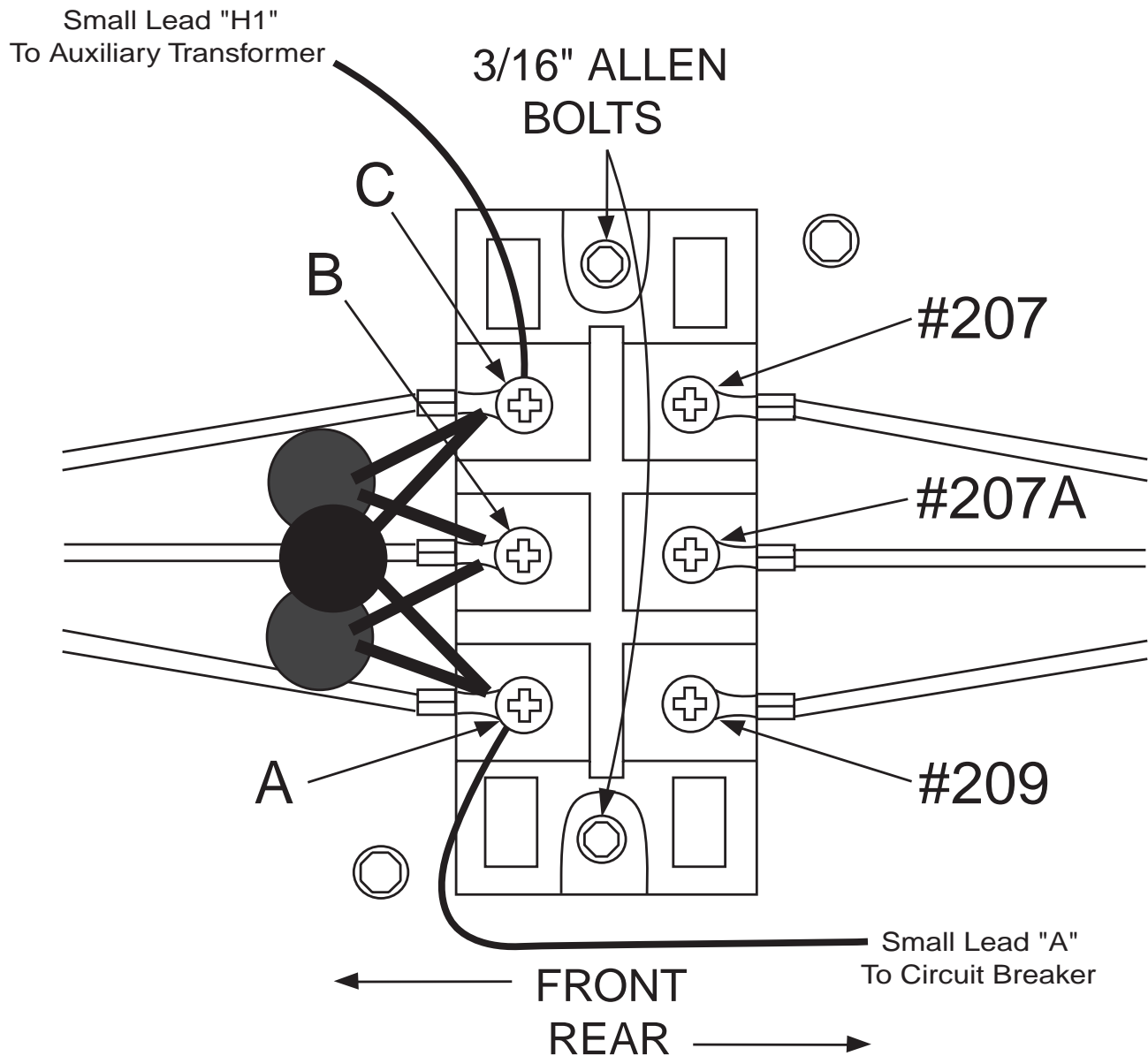

V350-PRO

LINCOLN[®]
ELECTRIC

V350-PRO



TROUBLESHOOTING & REPAIR

OUTPUT RECTIFIER MODULES REMOVAL AND REPLACEMENT



WARNING

Service and repair should be performed by only Lincoln Electric factory trained personnel. Unauthorized repairs performed on this equipment may result in danger to the technician or machine operator and will invalidate your factory warranty. For your safety and to avoid electrical shock, please observe all safety notes and precautions detailed throughout this manual.

If for any reason you do not understand the test procedures or are unable to perform the test/repairs safely, contact the Lincoln Electric Service Department for electrical troubleshooting assistance before you proceed. Call 1-800-833-9353 (WELD).

DESCRIPTION

The following procedure will aid the technician in removing the output rectifier modules for maintenance or replacement.

MATERIALS NEEDED

3/16" Allen wrench
9/64" Allen wrench
5/16" Nut Driver
7/16" Wrench
Flathead Screwdriver
Penetrox A-13 Heatsink Compound
Thin Knife/Screwdriver

This procedure takes approximately 30 minutes to perform.

V350-PRO



TROUBLESHOOTING & REPAIR

OUTPUT RECTIFIER MODULES

REMOVAL AND REPLACEMENT *(continued)*

PROCEDURE

1. Remove input power to the V350-PRO.
2. Using a 5/16" nut driver remove the case wrap-around cover.
3. Perform the **Input Filter Capacitor Discharge Procedure** detailed earlier in this section.
4. Locate the output diode modules located behind the snubber board. See figure F.38.
5. Before the output rectifier modules can be reached, the **Snubber Board Removal Procedure** must be performed.
6. After the snubber board is removed, remove the four leads connected to the modules using a 3/16" allen wrench. These leads are #X4, #X2, #20, #40. Note their positions for reassembly. **See Figure F.39.**
7. Remove the copper plates from the tops of the modules.

FIGURE F.38. – OUTPUT RECTIFIER MODULE LEAD LOCATIONS

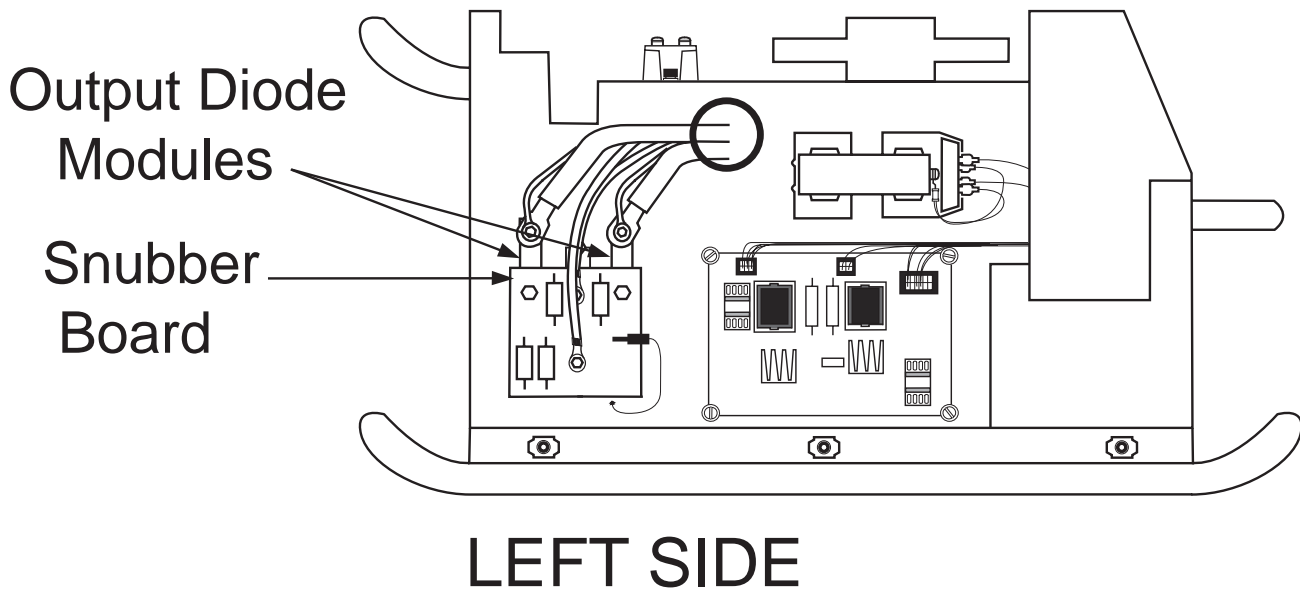

V350-PRO



TROUBLESHOOTING & REPAIR

OUTPUT RECTIFIER MODULES

REMOVAL AND REPLACEMENT *(continued)*

8. Under the copper plate previously removed, there is an allen bolt. Remove it using a 9/64" allen wrench. See Figure F.39.
9. Using a 7/16" socket remove the mounting bolts at the top and bottom of the modules. See Figure F.39.
10. The output rectifier modules are ready for removal and/or replacement.
11. Before replacing the diode module, apply a thin even coat of Penetrox A-13 heatsink compound to the bottom surface of the diode module. Note: Keep the compound away from the mounting holes.
12. Press the module firmly against the sink while aligning the mounting holes. Insert each outer screw through a spring washer and then a plain washer and into the holes. Start threading all three screws into the heat sink (2 or 3 turns by hand).
13. The screw threads may catch on the threads of the heat sink, so be sure to get the face of the screw into contact with the surface of the module (using just hand torque).
14. Using a 7/16" socket, tighten each mounting bolt to between 5 and 10 inch pounds.
15. Tighten the center allen screw to between 12 and 18 inch pounds.
16. Tighten each mounting bolt again (30 to 40 inch pounds this time).
15. Replace leads #X2, #X4, #20, #40 to their original terminals in their proper positions. Torque bolts to 30-40 Inch Pounds.
16. Perform the **Snubber Board Replacement Procedure** detailed earlier in this section.
17. Replace the case wraparound cover.

FIGURE F.39. - OUTPUT RECTIFIER MODULE MOUNTING BOLT LOCATIONS

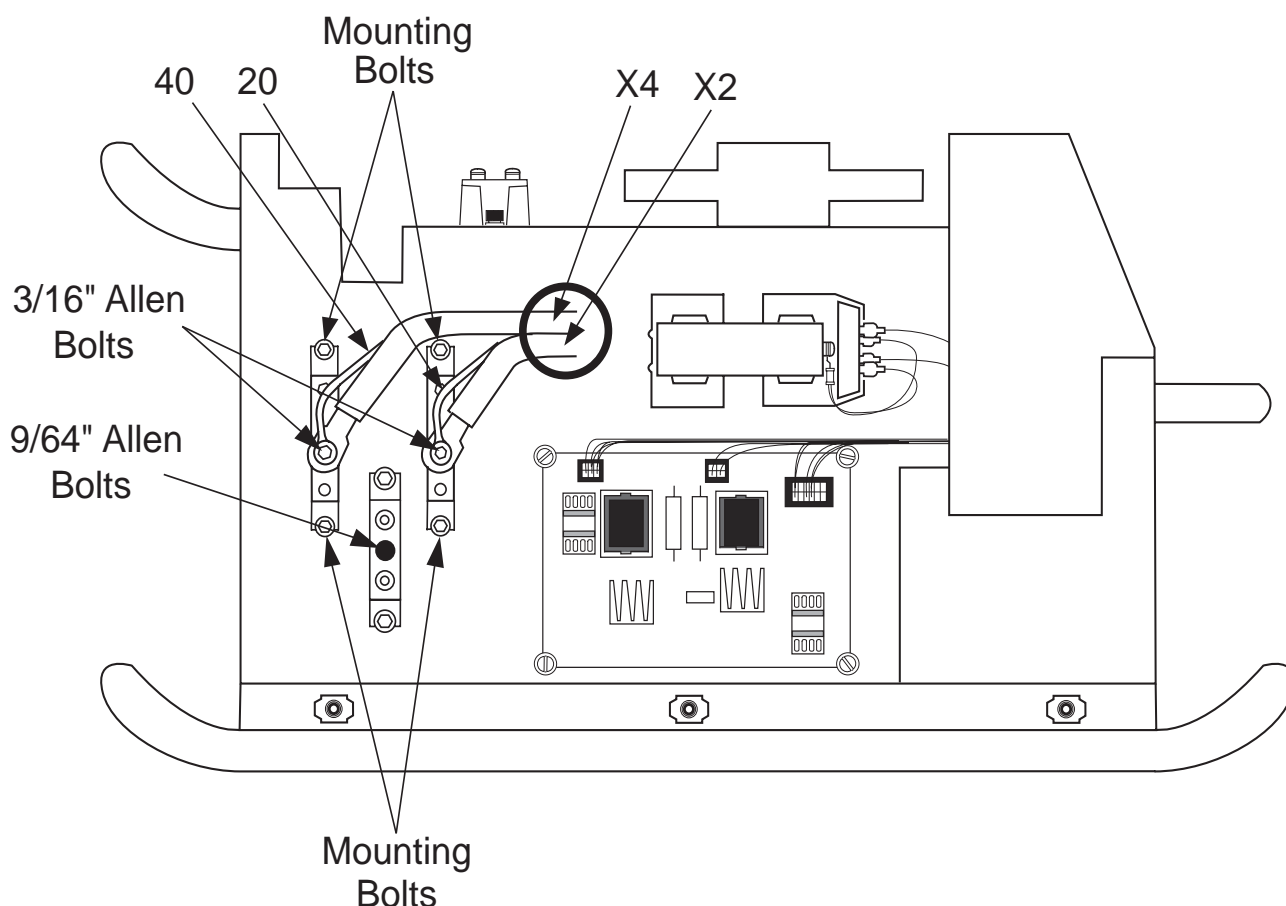

V350-PRO

LINCOLN[®]
ELECTRIC

V350-PRO



TROUBLESHOOTING & REPAIR

CURRENT TRANSDUCER REMOVAL AND REPLACEMENT



WARNING

Service and repair should be performed by only Lincoln Electric factory trained personnel. Unauthorized repairs performed on this equipment may result in danger to the technician or machine operator and will invalidate your factory warranty. For your safety and to avoid electrical shock, please observe all safety notes and precautions detailed throughout this manual.

If for any reason you do not understand the test procedures or are unable to perform the test/repairs safely, contact the Lincoln Electric Service Department for electrical troubleshooting assistance before you proceed. Call 1-800-833-9353 (WELD).

DESCRIPTION

The following procedure will aid the technician in removing the current transducer for maintenance or replacement.

MATERIALS NEEDED

- 5/16" Nut Driver
- 1/4" Nut Driver
- 1/2" Nut driver
- 3/8" Nut Driver
- Channel Locks
- Flathead Screwdriver
- Phillips Head Screwdriver
- Hammer
- Crescent Wrench
- Pliers

This procedure takes approximately 45 minutes to perform.

V350-PRO



TROUBLESHOOTING & REPAIR

CURRENT TRANSDUCER REMOVAL AND REPLACEMENT *(continued)*

PROCEDURE

1. Remove input power to the V350-PRO.
2. Using a 5/16" nut driver remove the case wrap-around cover.
3. Perform the ***Input Filter Capacitor Discharge Procedure*** detailed earlier in this section.
4. Using a 5/16" nut driver remove the four screws from the bottom and right side of the rear assembly. See Figure F.40.

FIGURE F.40. – CASE BACK SCREW LOCATIONS

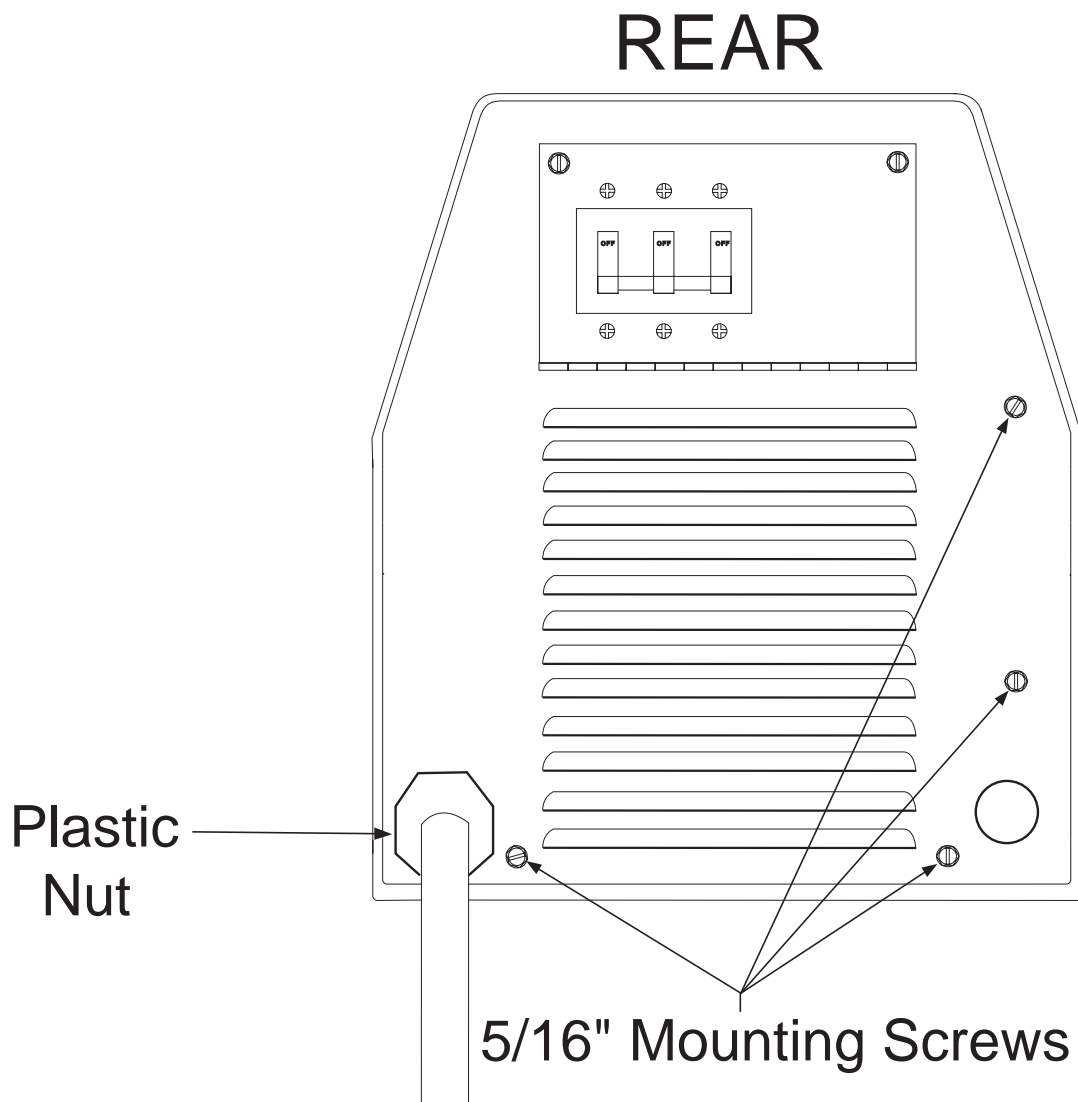

V350-PRO

LINCOLN[®]
ELECTRIC

TROUBLESHOOTING & REPAIR

CURRENT TRANSDUCER REMOVAL AND REPLACEMENT *(continued)*

5. Label and remove the five leads connected to the reconnect panel. Pliers may be necessary.
6. Label and remove the two leads connected to the CB2 circuit breaker.
7. Using a crescent wrench, remove the large plastic nut from around the input power line located at bottom of the rear assembly. See Figure F.41.
8. Locate the steel nut located directly on the other side of the rear assembly behind the plastic nut that was previously removed. See Figure F.41.
9. Using a hammer and a flathead screwdriver, firmly tap the metal nut from the bottom of one of its ribs. This tapping will loosen the nut. Note: Be sure to tap from the bottom so the nut loosens in a counter clockwise fashion if viewed from the front of the machine.
10. Using a 3/8" nut driver label and remove leads #202, #203, #206, #207A from the reconnect switches. See Figure F.41.

FIGURE F.41. LEAD LOCATIONS

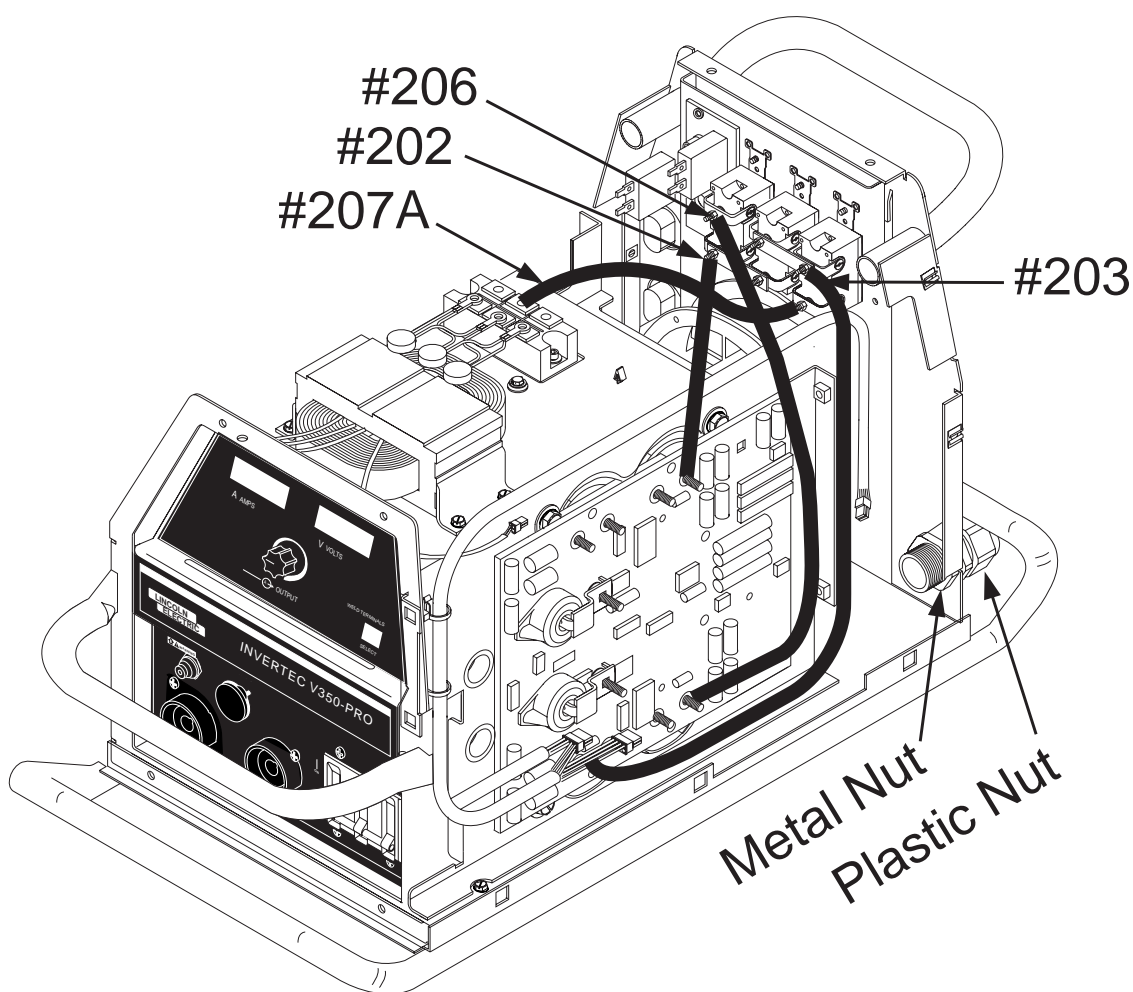

V350-PRO

LINCOLN[®]
ELECTRIC

TROUBLESHOOTING & REPAIR

CURRENT TRANSDUCER REMOVAL AND REPLACEMENT *(continued)*

11. The back of the machine may now gently be pulled away to gain access to the current transducer. Note: The rear of the machine cannot be removed completely.
12. Carefully swing the rear of the machine open to the left while facing the rear of the machine.
13. Perform the **Snubber Board Removal Procedure**.
14. Remove leads #X2 and #20 from the output diode module.
15. Remove leads #X4 and #40 from the other output diode module.
16. Using a 3/8" wrench, remove the three mounting screws from the output diode heatsink assembly. Take note placement of insulation for reassembly. See Figure F.42.
17. Cut any necessary cable ties and carefully remove the heavy lead from the diode heatsink using a 1/2" nut driver.
18. Remove the output diode heatsink assembly through the rear of the machine.
19. Remove plug #J90 from the current transducer.
20. Using a 3/8" nut driver, remove the two mounting nuts from the current transducer.

FIGURE F.42- OUTPUT HEATSINK MOUNTING SCREW LOCATION

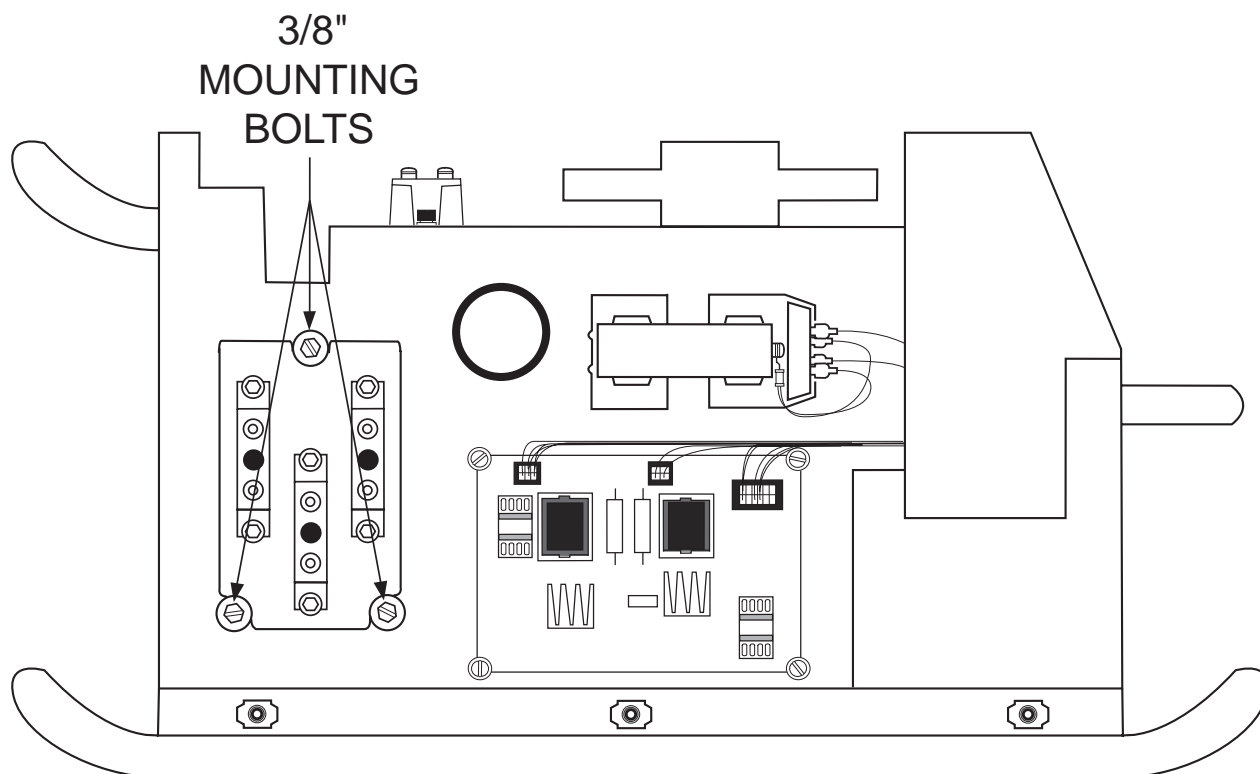

V350-PRO

LINCOLN[®]
ELECTRIC

TROUBLESHOOTING & REPAIR

CURRENT TRANSDUCER REMOVAL AND REPLACEMENT (*continued*)

21. Replace the current transducer.
22. Replace the two 3/8" mounting nuts previously removed.
23. Reconnect plug #J90 to the current transducer.
24. Replace any necessary cable ties previously cut.
25. From the rear of the machine, replace the heavy flex lead to the bottom of the output diode heatsink assembly using a 1/2" wrench. Note: Don't forget to include all washers.
26. Replace the output diode heatsink assembly previously removed using a 3/8" wrench.

Note: **Be sure to place insulation in its original location.**
27. Replace leads X2, #20, X4, # 40 previously removed from the two output diode modules. Torque to 30-40 inch lbs.
28. Perform the ***Snubber Board Replacement Procedure***.
29. The rear of the machine may now be placed back into its original position.
30. Using a 3/8" wrench, replace leads #202, #203, #206, and #207A previously removed from the reconnect switches.
31. Tighten the metal nut previously removed from the inside of the rear wall on the back of the machine. Channel locks may be necessary.
32. Replace the large plastic nut from around input power line located at the back of the machine.
33. Replace the five leads to the reconnect panel in their proper locations.
34. Replace the two CB2 circuit breaker leads previously removed.
35. Using a 5/16" nut driver, replace the four screws at the bottom and right side of the rear assembly.
36. Replace the case wraparound cover.
37. Perform the ***Voltage and Current Calibration Procedure***.

TROUBLESHOOTING AND REPAIR

RETEST AFTER REPAIR

Retest a machine:

If it is rejected under test for any reason that requires you to remove any part which could affect the machine's electrical characteristics.

If you repair or replace any electrical components:

Press and hold the MODE SELECT button (or the MEMORY button if an advanced process panel is installed) while applying power to the machine. Rotate the output control knob until the display reads SPIdIAG. Release the MODE SELECT button.

| Test Steps | Required Action | Expected Results | |
|-----------------------------------------------------------------------------------------------|------------------------------------------------------------------------------------------------------------------------------------------------------------------------------------------------|------------------|-------------|
| | | Lft. display | Rt. display |
| 1 | Adjust the output control potentiometer to its highest setting (completely clockwise). | oCP | HI |
| 2 | Adjust the output control potentiometer to its lowest setting (completely counterclockwise). | oCP | Lo |
| NOTE: If a standard Mode Select Panel is not installed in the machine, skip steps 3-12 | | | |
| 3 | Adjust the hot start potentiometer to its highest setting. | HSP | HI |
| 4 | Adjust the hot start potentiometer to its lowest setting. | HSP | Lo |
| 5 | Adjust the arc control potentiometer to its highest setting. | ACP | HI |
| 6 | Adjust the arc control potentiometer to its lowest setting. | ACP | Lo |
| 7 | All weld mode indicator LEDs should be off. Press the weld mode select push button to select the first weld mode. Only the top weld mode indicator LED should be on, all others should be off. | NodE | 1 |
| 8 | Press the weld mode select push button again to select the second weld mode. Only the second weld mode indicator LED should be on, all others should be off. | NodE | 2 |
| 9 | Press the weld mode select push button again to select the third weld mode. Only the third weld mode indicator LED should be on, all others should be off. | NodE | 3 |
| 10 | Press the weld mode select push button again to select the fourth weld mode. Only the fourth weld mode indicator LED should be on, all others should be off. | NodE | 4 |
| 11 | Press the weld mode select push button again to select the fifth weld mode. Only the bottom weld mode indicator LED should be on, all others should be off. | NodE | 5 |
| 12 | Press the weld mode select push button again and verify that all weld mode indicator LEDs are off. The test will automatically advance to step 25 | NodE | CLr |

V350-PRO



TROUBLESHOOTING AND REPAIR

RETEST AFTER REPAIR

| Test Steps | Required Action | Expected Results | |
|---------------------------------------------------------------------------------------------|-----------------------------------------------------------------------------------------------------------------------------------------------------------------------------------------------------------------------------------------------------------------|------------------|-------------|
| | | Lft. display | Rt. display |
| NOTE: If an Advanced Process Panel is not installed in the machine, skip steps 13-24 | | | |
| 13 | Turn the Advanced Process Panel left encoder clockwise until the value displayed on the Advanced Process Panel lower left display equals 100. Note that this should require exactly one revolution of the encoder knob. | LEnc | =100 |
| 14 | Turn the Advanced Process Panel left encoder counter-clockwise until the value displayed on the Advanced Process Panel lower left display equals zero. Note that this should require exactly one revolution of the encoder knob. | LEnc | =0 |
| 15 | Turn the Advanced Process Panel right encoder clockwise until the value displayed on the Advanced Process Panel lower left display equals 100. Note that this should require exactly one revolution of the encoder knob. | rEnc | =100 |
| 16 | Turn the Advanced Process Panel right encoder counter-clockwise until the value displayed on the Advanced Process Panel lower left display equals zero. Note that this should require exactly one revolution of the encoder knob. | rEnc | =0 |
| 17 | Press and hold the Advanced Process Panel Memory button until the right display changes to on. | EorY | oFF |
| 18 | Release the Advanced Process Panel Memory button. | EorY | on |
| 19 | Press and hold the Advanced Process Panel Select button. | rSEL | oFF |
| 20 | Release the Advanced Process Panel Select button. | rSEL | on |
| 21 | Verify that the Advanced Process Panel upper left display contains the following pattern and that the brightness of the characters is uniform: "0123456789ABCDEF" Press and release the Advanced Process Panel Memory button to advance to the next step. | dISP | 1 |
| 22 | Verify that the Advanced Process Panel lower left display contains the following pattern and that the brightness of the characters is uniform: "0123456789ABCDEF" Press and release the Advanced Process Panel Memory button to advance to the next step. | dISP | 2 |

V350-PRO



TROUBLESHOOTING AND REPAIR**RETEST AFTER REPAIR**

| Test Steps | Required Action | Expected Results | |
|------------|------------------------------------------------------------------------------------------------------------------------------------------------------------------------------------------------------------------------------------------------------------------|------------------|-------------|
| | | Lft. display | Rt. display |
| 23 | Verify that the Advanced Process Panel upper right display contains the following pattern and that the brightness of the characters is uniform: "0123456789ABCDEF" Press and release the Advanced Process Panel Memory button to advance to the next step. | dlSP | 3 |
| 24 | Verify that the Advanced Process Panel lower right display contains the following pattern and that the brightness of the characters is uniform: "0123456789ABCDEF" Press and release the Advanced Process Panel Memory button to advance to the next step. | dlSP | 4 |
| 25 | The weld terminals "ON" and "REMOTE" LEDs should both be off. Press the weld terminals push button to select weld terminals (studs) "ON" and verify that the weld terminals "ON" LED turns on. | SudS | on |
| 26 | Press the weld terminals push button again to select weld terminals "REMOTE" and verify that the weld terminals "ON" LED turns off and that the weld terminals "REMOTE" LED turns on. | SudS | rE |
| 27 | Press the weld terminals push button again and verify that both of the weld terminals LEDs are off. | SudS | cLr |
| 28 | The "LOCAL" and "REMOTE" workpoint source LEDs should both be off. Press the workpoint source push button to select "LOCAL" and verify that the workpoint source "LOCAL" LED turns on and that the "REMOTE" workpoint source LED remains off. | LorE | LoCL |
| 29 | Press the workpoint source pushbutton again to select workpoint source "REMOTE" and verify that the workpoint source "LOCAL" LED turns off and the workpoint source "REMOTE" workpoint source LED turns on. | LorE | rE |
| 30 | Press the workpoint source pushbutton again and verify that both workpoint source LEDs are off. | LorE | cLr |
| 31 | This will only appear if a potentiometer is already connected to the 6-pin amphenol connector on the front of the machine. If this message appears, disconnect the potentiometer from the 6-pin amphenol connector. | dcon | 6-PIn roCP |
| 32 | Connect a remote output control potentiometer to the 6-pin amphenol connector on the front of the machine. | con | 6-PIn roCP |

V350-PRO



TROUBLESHOOTING AND REPAIR**RETEST AFTER REPAIR**

| Test Steps | Required Action | Expected Results | |
|------------|-------------------------------------------------------------------------------------------------------------------------------------------------------------------------------------------------------------------------------------------|------------------|-------------|
| | | Lft. display | Rt. display |
| 33 | Adjust the remote output control potentiometer connected to the 6-pin amphenol connector to its highest setting. | 6-PIn roCP | HI |
| 34 | Adjust the remote output control potentiometer connected to the 6-pin amphenol connector to its lowest setting. | 6-PIn roCP | Lo |
| 35 | This will only appear if a trigger switch is already connected to the 6-pin amphenol connector on the front of the machine and the trigger switch is presently on. Turn the trigger switch connected to the 6-pin amphenol connector off. | 6-PIn rlgr | oFF |
| 36 | Turn the trigger switch connected to the 6-pin amphenol connector on. | 6-PIn Rigr | on |
| 37 | Turn the trigger switch connected to the 6-pin amphenol connector off. | 6-PIn rLgr | oFF |
| 38 | This will only appear if a potentiometer is still connected to the 6-pin amphenol connector. If this message appears, disconnect the potentiometer from the 6-pin amphenol connector. | dcon | 6-PIn roCP |
| 39 | This will only appear if a potentiometer is already connected to the 14-pin amphenol connector. If this message appears, disconnect the potentiometer from the 14-pin amphenol connector. | dcon | 14-PIn roCP |
| 40 | Connect a remote output control potentiometer to the 14-pin amphenol connector. | con | 14-PIn roCP |
| 41 | Adjust the remote output control potentiometer connected to the 14-pin amphenol connector to its highest setting. | 14-PIn roCP | HI |
| 42 | Adjust the remote output control potentiometer connected to the 14-pin amphenol connector to its lowest setting. | 14-PIn roCP | Lo |
| 43 | This will only appear if a trigger switch is already connected to the 14-pin amphenol connector and the trigger switch is presently on. Turn the trigger switch connected to the 14-pin amphenol connector off. | 14-PIn rlgr | oFF |
| 44 | Turn the trigger switch connected to the 14-pin amphenol connector on. | 14-PIn rlgr | on |
| 45 | Turn the trigger switch connected to the 14-pin amphenol connector off. | 14-PIn rlgr | oFF |

V350-PRO



TROUBLESHOOTING AND REPAIR

RETEST AFTER REPAIR

| Test Steps | Required Action | Expected Results | |
|-------------------------------------------------------------------------------------------|---------------------------------------------------------------------------------------------------------------------------------------------------------------------------------------------------------------------------------------------------------------------------------------------------------------------------------------------------------------------------------------------------------------------------------------------------------------------------------------------------------------------------------------------------------------------------------------------------------------------------------|------------------|-------------|
| | | Lft. display | Rt. display |
| 46 | This will only appear if a potentiometer is still connected to the 14-pin amphenol connector. If this message appears, disconnect the potentiometer from the 14-pin amphenol connector. | dcon | 14-pin roCP |
| 47 | <p>Test steps 21-24 verify the functionality of the gas solenoid. If an oscilloscope is available, verify that the current flowing through the gas solenoid is zero before the solenoid is energized, increases to approximately 700mA (pull in current), remains at 700 mA for approximately 150 msec, and decreases to approximately 200mA (hold current). Press the local/remote pushbutton to turn the gas solenoid on.</p> <div style="text-align: center;"> <p>< - 150msec - ></p> </div> <p>Or, the signal can be verified by measuring 12.3 VDC +/- .5V from lead 553A to 554A (Lead 553A should be positive)</p> | GAS | On |
| 48 | Press the local/remote pushbutton again to turn the gas solenoid off. | GAS | OFF |
| After completing all of the above tests, the following will appear on the display. | | | |
| | Verify this message appears for approximately 3 seconds | DIAg | PASS |

TABLE OF CONTENTS -ELECTRICAL DIAGRAMS SECTION-

| | |
|------------------------------------------------|-----------|
| ELECTRICAL DIAGRAMS | SECTION G |
| WIRING DIAGRAM | G-2 |
| MACHINE SCHEMATIC | G-3 |
| CONTROL PC BOARD SCHEMATIC #1 | G-4 |
| CONTROL PC BOARD SCHEMATIC #2 | G-5 |
| CONTROL PC BOARD SCHEMATIC #3 | G-6 |
| CONTROL PC BOARD SCHEMATIC #4 | G-7 |
| CONTROL PC BOARD ASSEMBLY (L11088-1) | * |
| POWER SUPPLY PC BOARD SCHEMATIC | G-8 |
| POWER SUPPLY PC BOARD ASSEMBLY (G3632-2) | * |
| SWITCH PC BOARD SCHEMATIC | G-9 |
| SWITCH PC BOARD ASSEMBLY | G-10 |
| DISPLAY PC BOARD SCHEMATIC | G-11 |
| DISPLAY PC BOARD ASSEMBLY | G-12 |
| LED SELECT PC BOARD SCHEMATIC | G-13 |
| LED SELECT PC BOARD ASSEMBLY | G-14 |
| LED POTENTIOMETER PC BOARD SCHEMATIC | G-15 |
| LED POTENTIOMETER PC BOARD ASSEMBLY | G-16 |
| SPI REMOTE PC BOARD SCHEMATIC | G-17 |
| SPI REMOTE PC BOARD ASSEMBLY | G-18 |
| SNUBBER PC BOARD SCHEMATIC | G-19 |
| SNUBBER PC BOARD ASSEMBLY | G-20 |

* NOTE: Many PC Board Assemblies are now totally encapsulated and are therefore considered to be unserviceable. The Assembly numbers are provided on this page but the actual drawings are no longer included.

WIRING DIAGRAM INVERTEC V350

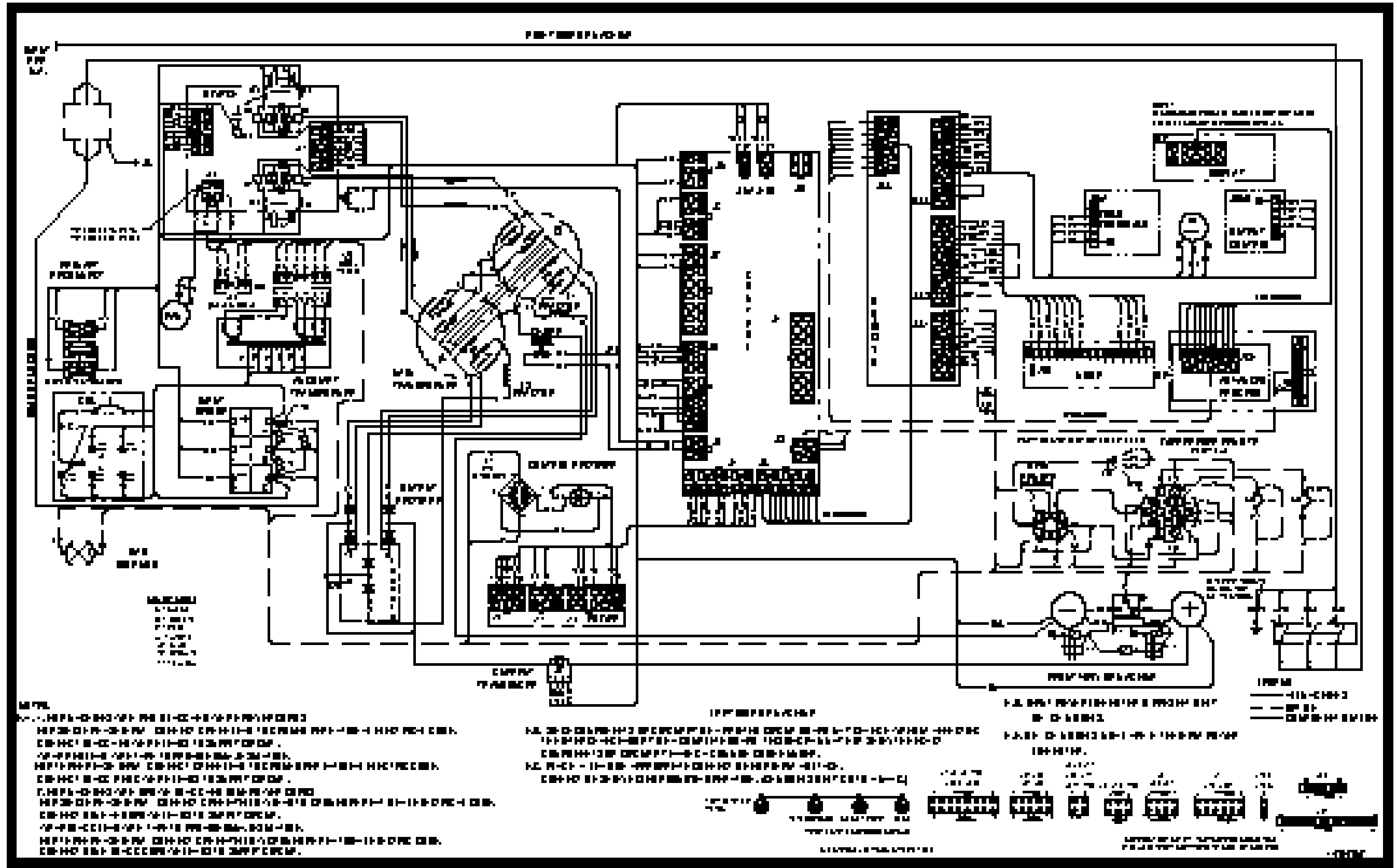

NOTE: This diagram is for reference only. It may not be accurate for all machines covered by this manual. The wiring diagram specific to your code is pasted inside one of the enclosure panels of your machine.

SCHEMATIC - COMPLETE MACHINE

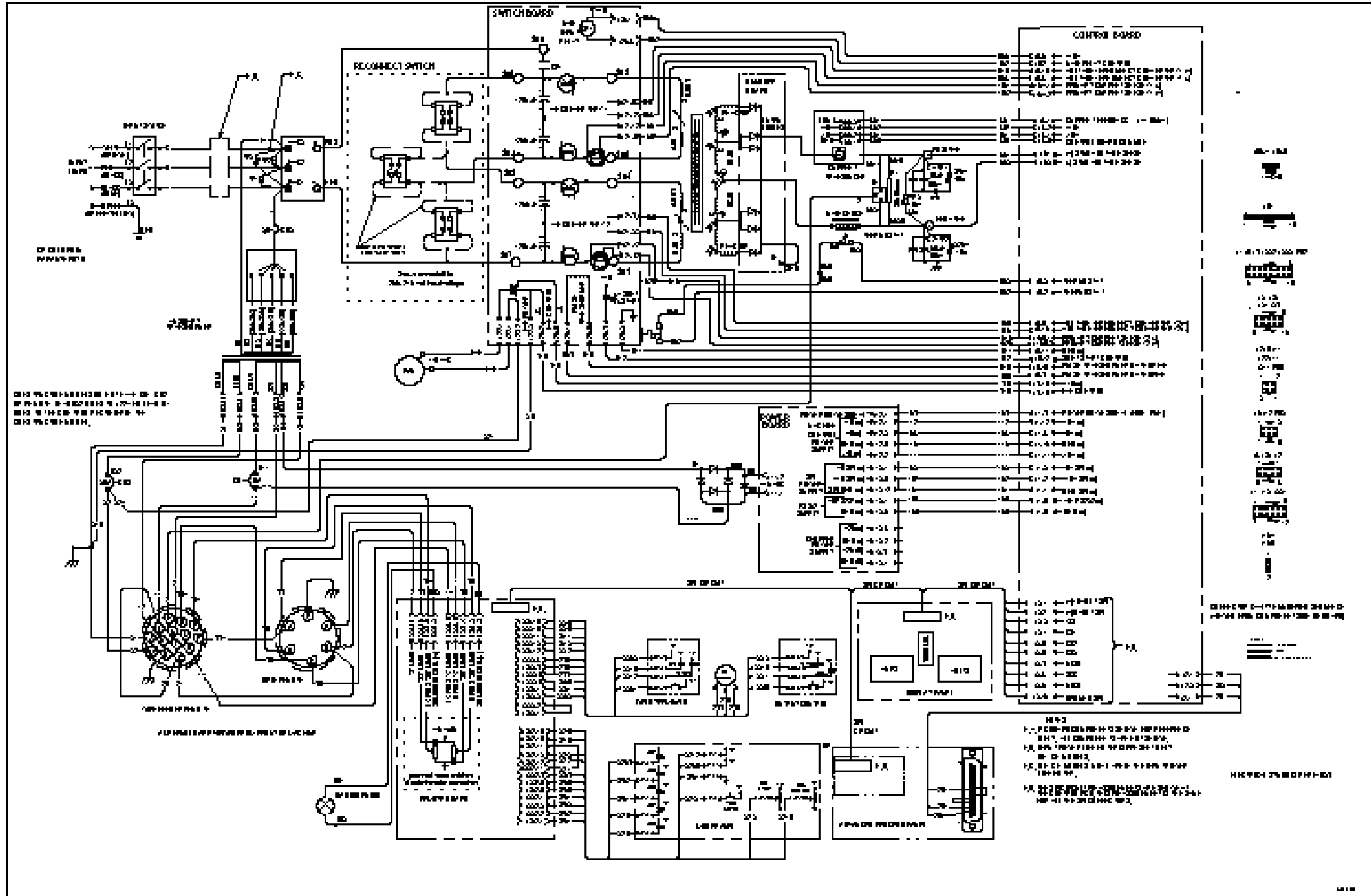

NOTE: This diagram is for reference only. It may not be accurate for all machines covered by this manual.

SCHEMATIC - DIGITAL CONTROL PC BOARD #1

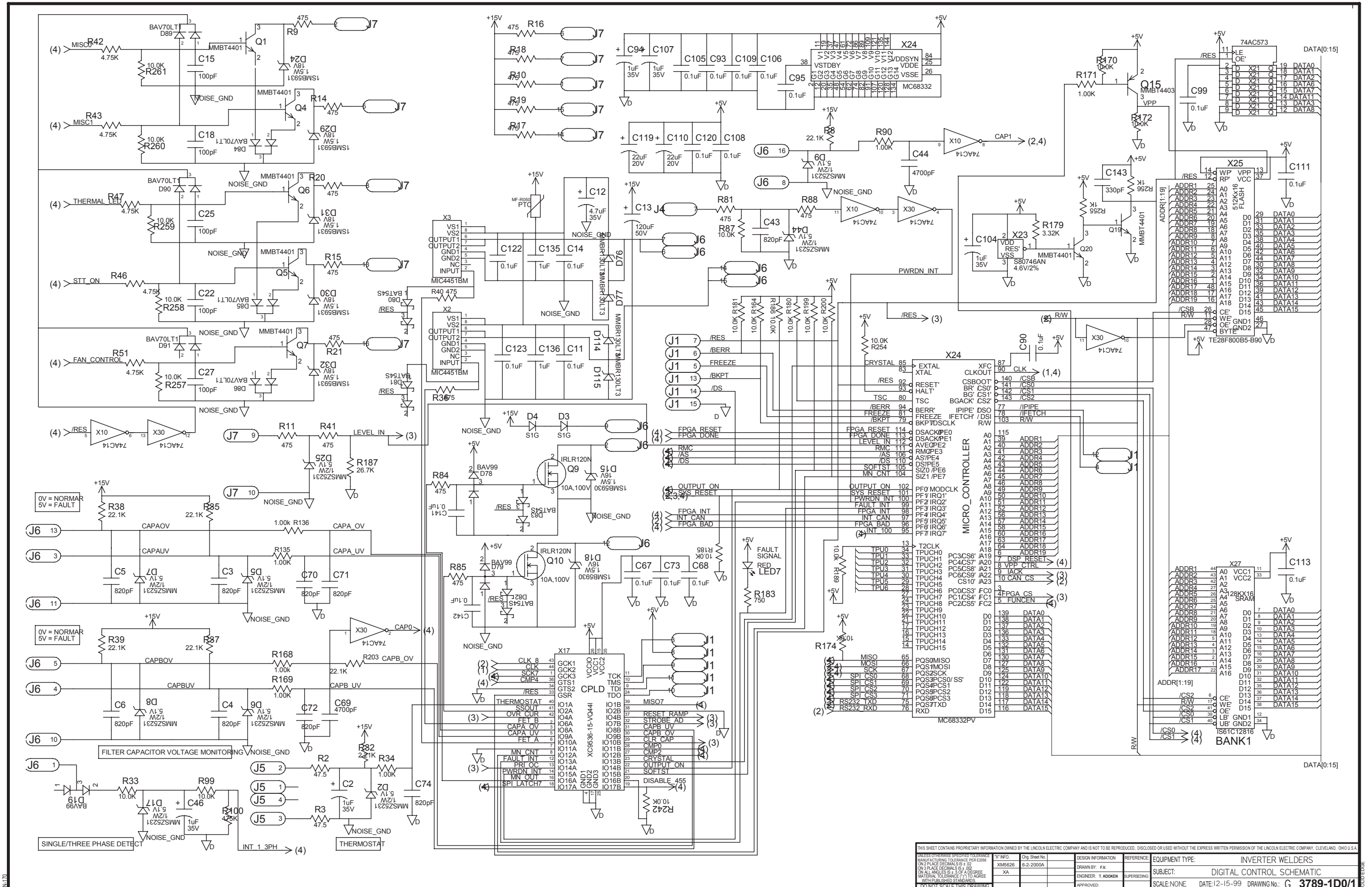

NOTE: This diagram is for reference only. It may not be accurate for all machines covered by this manual.

SCHEMATIC - DIGITAL CONTROL PC BOARD #2

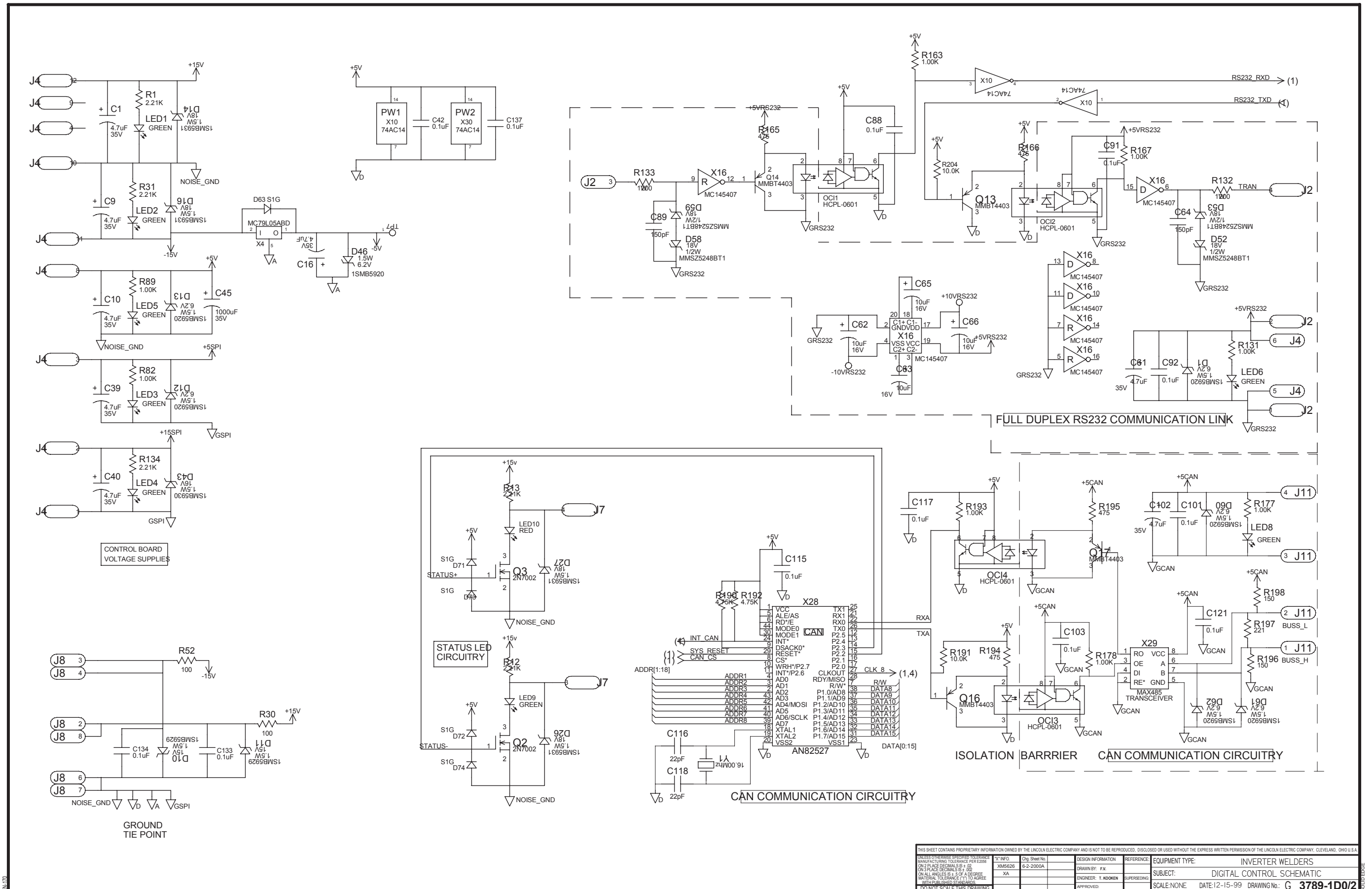

NOTE: This diagram is for reference only. It may not be accurate for all machines covered by this manual.

SCHEMATIC - DIGITAL CONTROL PC BOARD #3

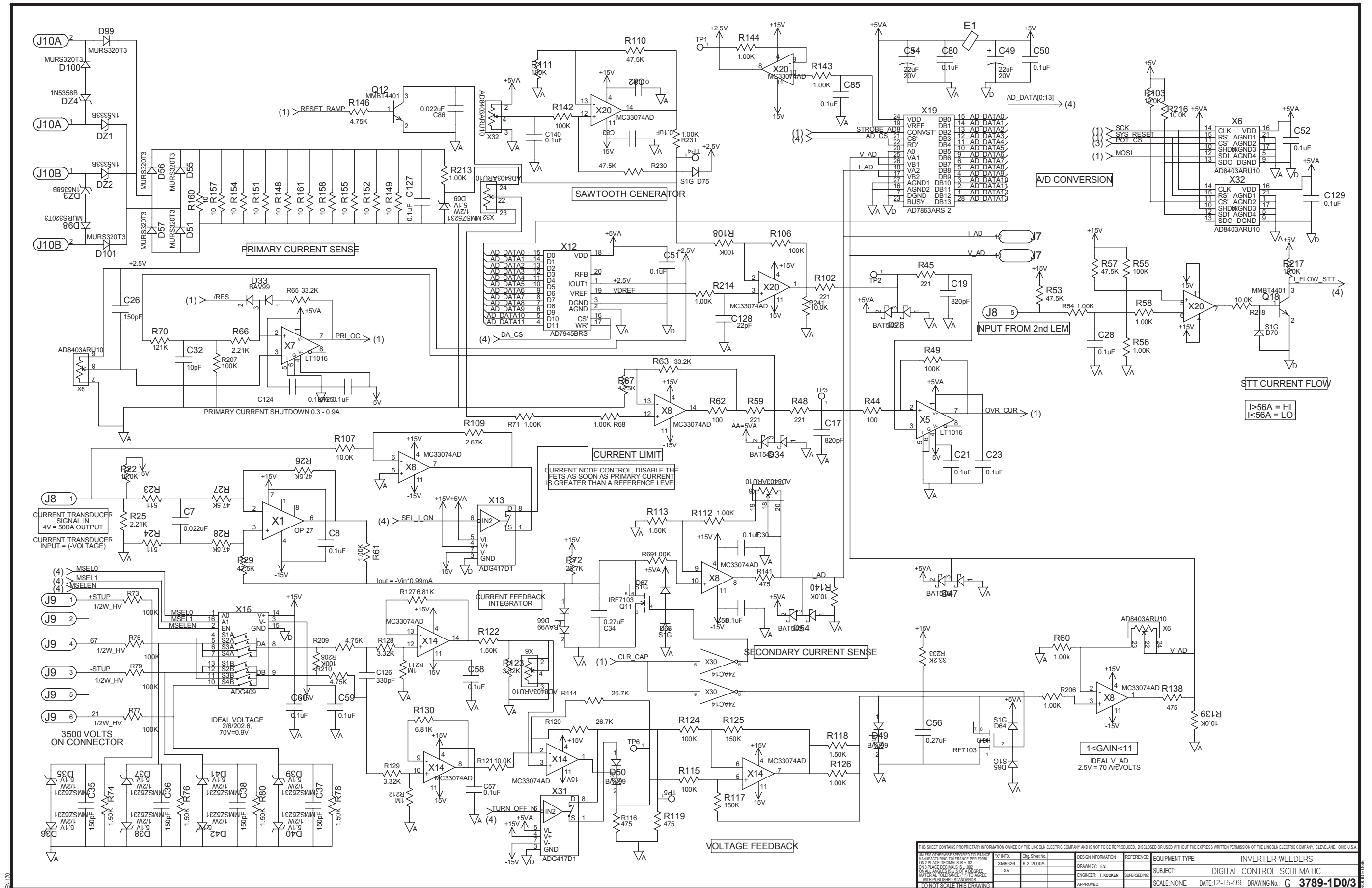

NOTE: This diagram is for reference only. It may not be accurate for all machines covered by this manual.

SCHEMATIC - DIGITAL CONTROL PC BOARD # 4

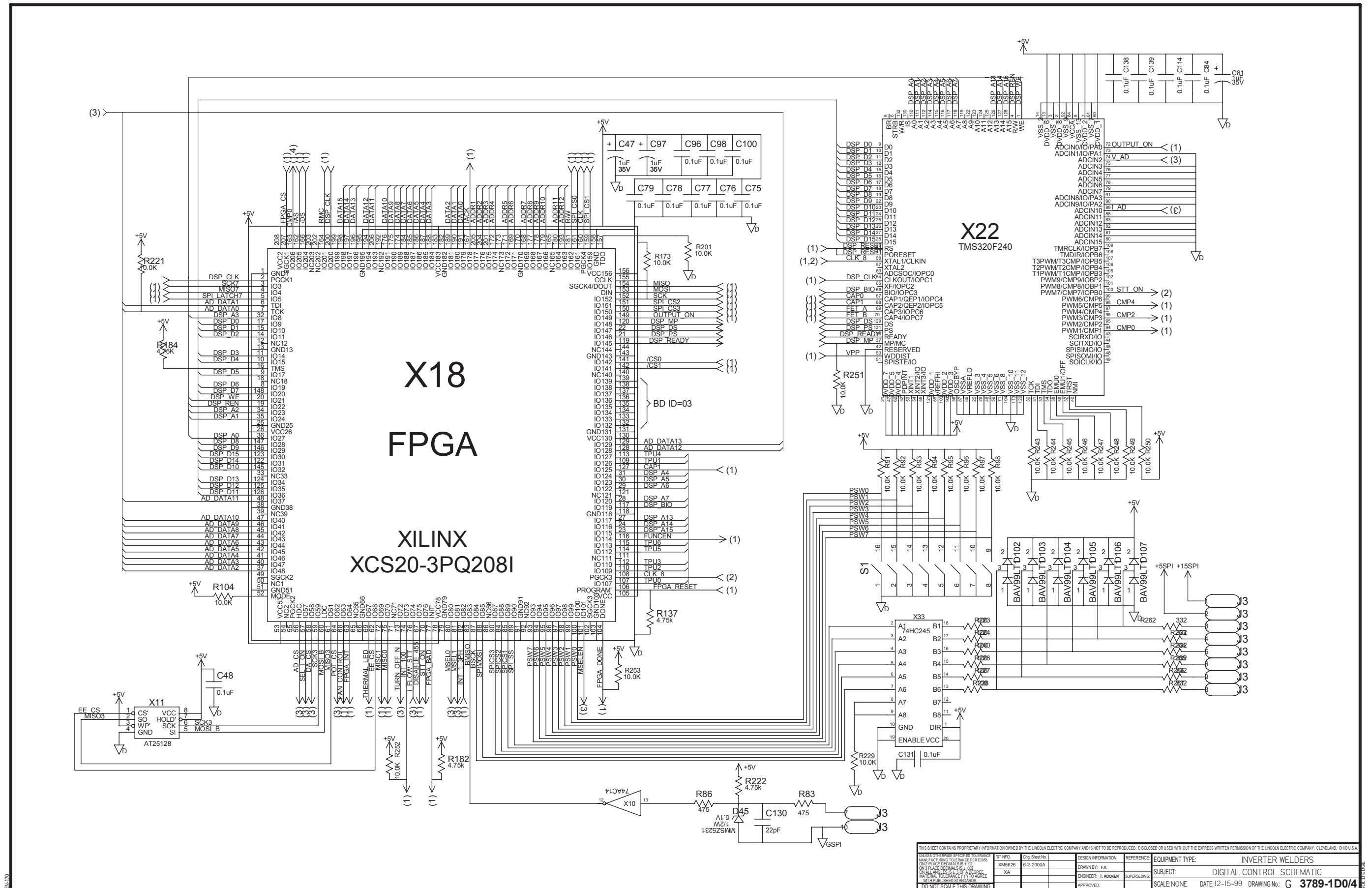

NOTE: This diagram is for reference only. It may not be accurate for all machines covered by this manual.

SCHEMATIC - SWITCH PRINTED CIRCUIT BOARD

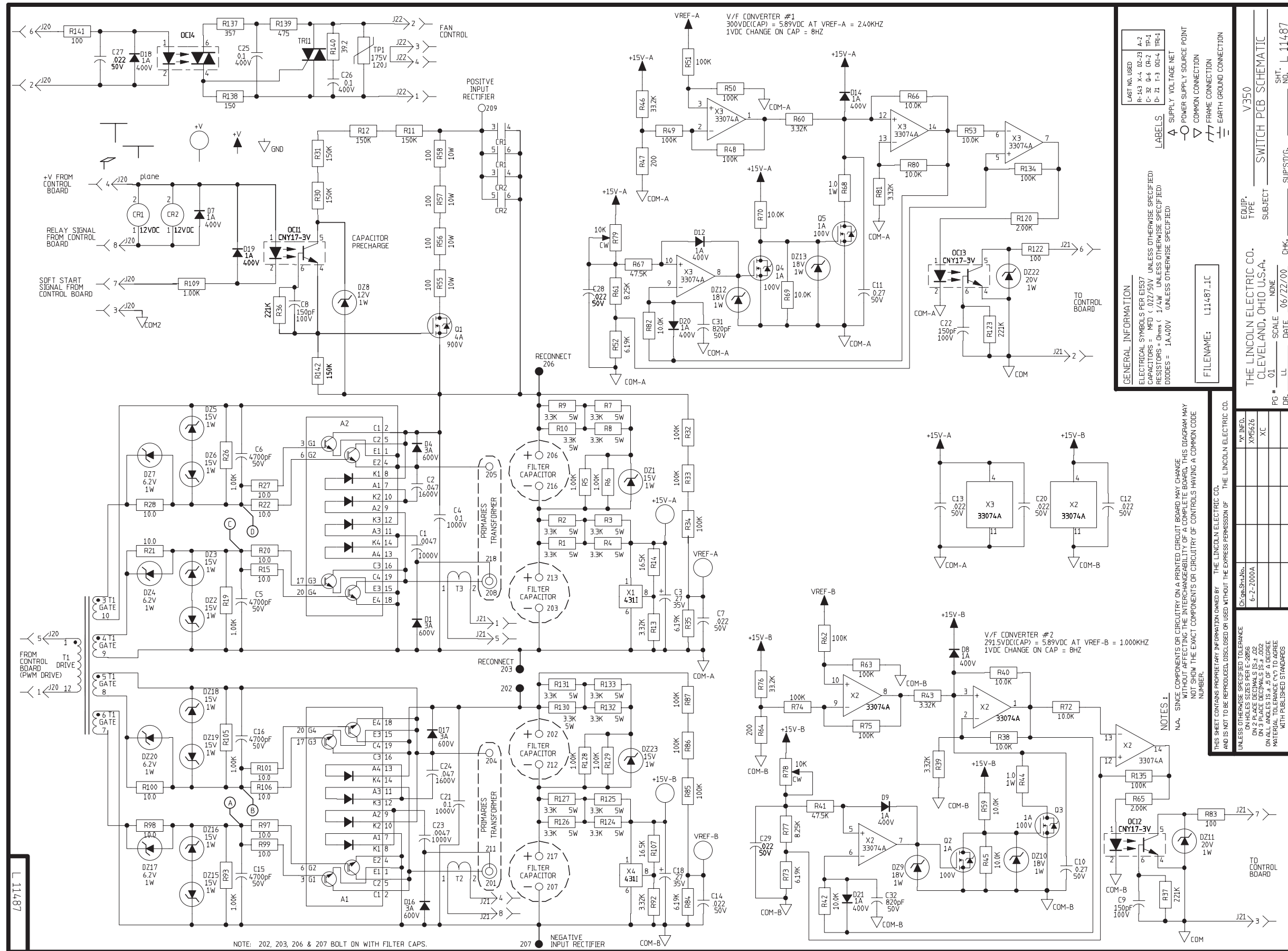

GENERAL INFORMATION

ELECTRICAL SYMBOLS PER EIS37
 CAPACITORS = MFD (.022/50V UNLESS OTHERWISE SPECIFIED)
 RESISTORS = OHMS (1/4W UNLESS OTHERWISE SPECIFIED)
 DIODES = 1A, 400V UNLESS OTHERWISE SPECIFIED

LAST NO. USED

| | | | | | | |
|---|------|---|-----|-------|------|---|
| R | 1-13 | X | 4 | DC-23 | 4 | 2 |
| C | 1-3 | P | 6 | DC-2 | TP-1 | |
| D | 1-2 | I | 1-3 | DC-4 | TR-1 | |

LABELS

- ▲ SUPPLY VOLTAGE NET
- ⊖ POWER SUPPLY SOURCE POINT
- COMMON CONNECTION
- FRAME CONNECTION
- ⊥ EARTH GROUND CONNECTION

FILENAME: L11487.1C

DR. _____ DATE 06/22/00 CHK. _____ SHT. L 11487

THE LINCOLN ELECTRIC CO.
 CLEVELAND, OHIO U.S.A.

EQUIP. TYPE V350
 SUBJECT SWITCH PCB SCHEMATIC

NOTES

N/A. SINCE COMPONENTS OR CIRCUITRY ON A PRINTED CIRCUIT BOARD MAY CHANGE WITHOUT AFFECTING THE INTERCHANGEABILITY OF A COMPLETE BOARD, THIS DIAGRAM MAY NOT SHOW THE EXACT COMPONENTS OR CIRCUITRY OF CONTROLS HAVING A COMMON CODE NUMBER.

THIS SHEET CONTAINS PROPRIETARY INFORMATION OWNED BY THE LINCOLN ELECTRIC CO. AND IS NOT TO BE REPRODUCED, DISCLOSED OR USED WITHOUT THE EXPRESS PERMISSION OF THE LINCOLN ELECTRIC CO.

UNLESS OTHERWISE SPECIFIED TOLERANCE
 ON HOLES SIZES PER E-2866
 ON DIMENSIONS PER E-2866
 ON 2 PLACE DECIMALS IS ± .002
 ON ALL ANGLES IS ± .5 OF A DEGREE
 MATERIAL TOLERANCE C-3 TO APPLY
 WITH PUBLISHED STANDARDS

NOTE: 202, 203, 206 & 207 BOLT ON WITH FILTER CAPS.

207 NEGATIVE INPUT RECTIFIER

NOTE: This diagram is for reference only. It may not be accurate for all machines covered by this manual.

PC BOARD ASSEMBLY-SWITCH

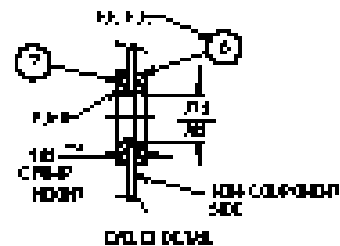
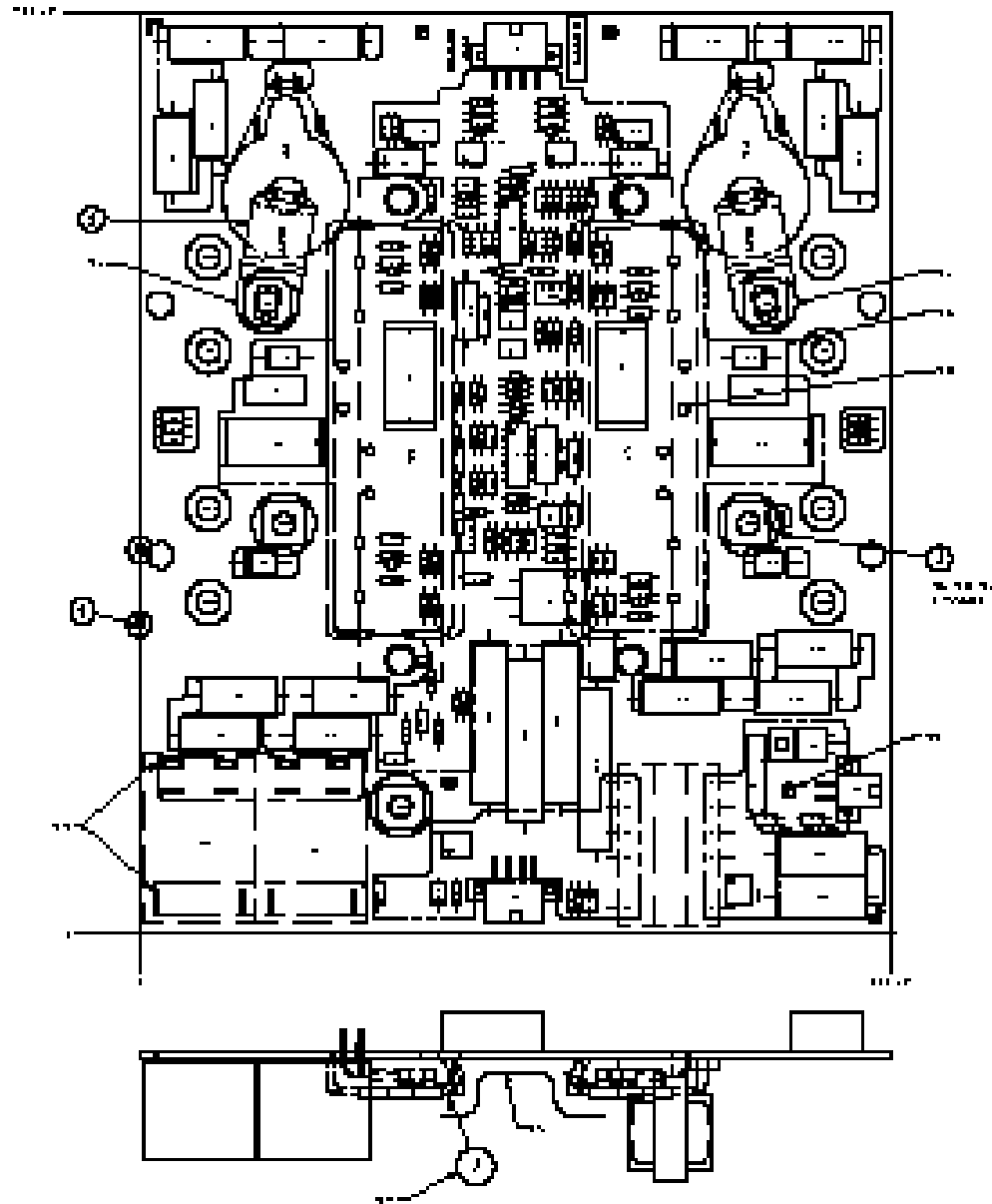

MANUFACTURED BY:
 PART NO. IDENTIFICATION CODE

NOTE:
 1. THIS BOARD IS DESIGNED TO BE USED WITH THE...
 2. THE BOARD IS DESIGNED TO BE USED WITH THE...
 3. THE BOARD IS DESIGNED TO BE USED WITH THE...
 4. THE BOARD IS DESIGNED TO BE USED WITH THE...
 5. THE BOARD IS DESIGNED TO BE USED WITH THE...
 6. THE BOARD IS DESIGNED TO BE USED WITH THE...
 7. THE BOARD IS DESIGNED TO BE USED WITH THE...
 8. THE BOARD IS DESIGNED TO BE USED WITH THE...
 9. THE BOARD IS DESIGNED TO BE USED WITH THE...
 10. THE BOARD IS DESIGNED TO BE USED WITH THE...
 11. THE BOARD IS DESIGNED TO BE USED WITH THE...
 12. THE BOARD IS DESIGNED TO BE USED WITH THE...
 13. THE BOARD IS DESIGNED TO BE USED WITH THE...
 14. THE BOARD IS DESIGNED TO BE USED WITH THE...
 15. THE BOARD IS DESIGNED TO BE USED WITH THE...

FOR PARTS AND REPAIR INFORMATION CONTACT:
 LINCOLN ELECTRIC COMPANY
 235 N. LAKE ST., WAUWATOSA, WI 53190
 TEL: 414/771-1000

| REF. NO. | QTY. | DESCRIPTION | MANUFACTURER |
|----------|------|-------------|--------------|
| 11-001 | 1 | RESISTOR | RESISTOR |
| 11-002 | 1 | RESISTOR | RESISTOR |
| 11-003 | 1 | RESISTOR | RESISTOR |
| 11-004 | 1 | RESISTOR | RESISTOR |
| 11-005 | 1 | RESISTOR | RESISTOR |
| 11-006 | 1 | RESISTOR | RESISTOR |
| 11-007 | 1 | RESISTOR | RESISTOR |
| 11-008 | 1 | RESISTOR | RESISTOR |
| 11-009 | 1 | RESISTOR | RESISTOR |
| 11-010 | 1 | RESISTOR | RESISTOR |
| 11-011 | 1 | RESISTOR | RESISTOR |
| 11-012 | 1 | RESISTOR | RESISTOR |
| 11-013 | 1 | RESISTOR | RESISTOR |
| 11-014 | 1 | RESISTOR | RESISTOR |
| 11-015 | 1 | RESISTOR | RESISTOR |
| 11-016 | 1 | RESISTOR | RESISTOR |
| 11-017 | 1 | RESISTOR | RESISTOR |
| 11-018 | 1 | RESISTOR | RESISTOR |
| 11-019 | 1 | RESISTOR | RESISTOR |
| 11-020 | 1 | RESISTOR | RESISTOR |
| 11-021 | 1 | RESISTOR | RESISTOR |
| 11-022 | 1 | RESISTOR | RESISTOR |
| 11-023 | 1 | RESISTOR | RESISTOR |
| 11-024 | 1 | RESISTOR | RESISTOR |
| 11-025 | 1 | RESISTOR | RESISTOR |
| 11-026 | 1 | RESISTOR | RESISTOR |
| 11-027 | 1 | RESISTOR | RESISTOR |
| 11-028 | 1 | RESISTOR | RESISTOR |
| 11-029 | 1 | RESISTOR | RESISTOR |
| 11-030 | 1 | RESISTOR | RESISTOR |
| 11-031 | 1 | RESISTOR | RESISTOR |
| 11-032 | 1 | RESISTOR | RESISTOR |
| 11-033 | 1 | RESISTOR | RESISTOR |
| 11-034 | 1 | RESISTOR | RESISTOR |
| 11-035 | 1 | RESISTOR | RESISTOR |
| 11-036 | 1 | RESISTOR | RESISTOR |
| 11-037 | 1 | RESISTOR | RESISTOR |
| 11-038 | 1 | RESISTOR | RESISTOR |
| 11-039 | 1 | RESISTOR | RESISTOR |
| 11-040 | 1 | RESISTOR | RESISTOR |
| 11-041 | 1 | RESISTOR | RESISTOR |
| 11-042 | 1 | RESISTOR | RESISTOR |
| 11-043 | 1 | RESISTOR | RESISTOR |
| 11-044 | 1 | RESISTOR | RESISTOR |
| 11-045 | 1 | RESISTOR | RESISTOR |
| 11-046 | 1 | RESISTOR | RESISTOR |
| 11-047 | 1 | RESISTOR | RESISTOR |
| 11-048 | 1 | RESISTOR | RESISTOR |
| 11-049 | 1 | RESISTOR | RESISTOR |
| 11-050 | 1 | RESISTOR | RESISTOR |
| 11-051 | 1 | RESISTOR | RESISTOR |
| 11-052 | 1 | RESISTOR | RESISTOR |
| 11-053 | 1 | RESISTOR | RESISTOR |
| 11-054 | 1 | RESISTOR | RESISTOR |
| 11-055 | 1 | RESISTOR | RESISTOR |
| 11-056 | 1 | RESISTOR | RESISTOR |
| 11-057 | 1 | RESISTOR | RESISTOR |
| 11-058 | 1 | RESISTOR | RESISTOR |
| 11-059 | 1 | RESISTOR | RESISTOR |
| 11-060 | 1 | RESISTOR | RESISTOR |
| 11-061 | 1 | RESISTOR | RESISTOR |
| 11-062 | 1 | RESISTOR | RESISTOR |
| 11-063 | 1 | RESISTOR | RESISTOR |
| 11-064 | 1 | RESISTOR | RESISTOR |
| 11-065 | 1 | RESISTOR | RESISTOR |
| 11-066 | 1 | RESISTOR | RESISTOR |
| 11-067 | 1 | RESISTOR | RESISTOR |
| 11-068 | 1 | RESISTOR | RESISTOR |
| 11-069 | 1 | RESISTOR | RESISTOR |
| 11-070 | 1 | RESISTOR | RESISTOR |
| 11-071 | 1 | RESISTOR | RESISTOR |
| 11-072 | 1 | RESISTOR | RESISTOR |
| 11-073 | 1 | RESISTOR | RESISTOR |
| 11-074 | 1 | RESISTOR | RESISTOR |
| 11-075 | 1 | RESISTOR | RESISTOR |
| 11-076 | 1 | RESISTOR | RESISTOR |
| 11-077 | 1 | RESISTOR | RESISTOR |
| 11-078 | 1 | RESISTOR | RESISTOR |
| 11-079 | 1 | RESISTOR | RESISTOR |
| 11-080 | 1 | RESISTOR | RESISTOR |
| 11-081 | 1 | RESISTOR | RESISTOR |
| 11-082 | 1 | RESISTOR | RESISTOR |
| 11-083 | 1 | RESISTOR | RESISTOR |
| 11-084 | 1 | RESISTOR | RESISTOR |
| 11-085 | 1 | RESISTOR | RESISTOR |
| 11-086 | 1 | RESISTOR | RESISTOR |
| 11-087 | 1 | RESISTOR | RESISTOR |
| 11-088 | 1 | RESISTOR | RESISTOR |
| 11-089 | 1 | RESISTOR | RESISTOR |
| 11-090 | 1 | RESISTOR | RESISTOR |
| 11-091 | 1 | RESISTOR | RESISTOR |
| 11-092 | 1 | RESISTOR | RESISTOR |
| 11-093 | 1 | RESISTOR | RESISTOR |
| 11-094 | 1 | RESISTOR | RESISTOR |
| 11-095 | 1 | RESISTOR | RESISTOR |
| 11-096 | 1 | RESISTOR | RESISTOR |
| 11-097 | 1 | RESISTOR | RESISTOR |
| 11-098 | 1 | RESISTOR | RESISTOR |
| 11-099 | 1 | RESISTOR | RESISTOR |
| 11-100 | 1 | RESISTOR | RESISTOR |
| 11-101 | 1 | RESISTOR | RESISTOR |
| 11-102 | 1 | RESISTOR | RESISTOR |
| 11-103 | 1 | RESISTOR | RESISTOR |
| 11-104 | 1 | RESISTOR | RESISTOR |
| 11-105 | 1 | RESISTOR | RESISTOR |
| 11-106 | 1 | RESISTOR | RESISTOR |
| 11-107 | 1 | RESISTOR | RESISTOR |
| 11-108 | 1 | RESISTOR | RESISTOR |
| 11-109 | 1 | RESISTOR | RESISTOR |
| 11-110 | 1 | RESISTOR | RESISTOR |
| 11-111 | 1 | RESISTOR | RESISTOR |
| 11-112 | 1 | RESISTOR | RESISTOR |
| 11-113 | 1 | RESISTOR | RESISTOR |
| 11-114 | 1 | RESISTOR | RESISTOR |
| 11-115 | 1 | RESISTOR | RESISTOR |
| 11-116 | 1 | RESISTOR | RESISTOR |
| 11-117 | 1 | RESISTOR | RESISTOR |
| 11-118 | 1 | RESISTOR | RESISTOR |
| 11-119 | 1 | RESISTOR | RESISTOR |
| 11-120 | 1 | RESISTOR | RESISTOR |
| 11-121 | 1 | RESISTOR | RESISTOR |
| 11-122 | 1 | RESISTOR | RESISTOR |
| 11-123 | 1 | RESISTOR | RESISTOR |
| 11-124 | 1 | RESISTOR | RESISTOR |
| 11-125 | 1 | RESISTOR | RESISTOR |
| 11-126 | 1 | RESISTOR | RESISTOR |
| 11-127 | 1 | RESISTOR | RESISTOR |
| 11-128 | 1 | RESISTOR | RESISTOR |
| 11-129 | 1 | RESISTOR | RESISTOR |
| 11-130 | 1 | RESISTOR | RESISTOR |
| 11-131 | 1 | RESISTOR | RESISTOR |
| 11-132 | 1 | RESISTOR | RESISTOR |
| 11-133 | 1 | RESISTOR | RESISTOR |
| 11-134 | 1 | RESISTOR | RESISTOR |
| 11-135 | 1 | RESISTOR | RESISTOR |
| 11-136 | 1 | RESISTOR | RESISTOR |
| 11-137 | 1 | RESISTOR | RESISTOR |
| 11-138 | 1 | RESISTOR | RESISTOR |
| 11-139 | 1 | RESISTOR | RESISTOR |
| 11-140 | 1 | RESISTOR | RESISTOR |
| 11-141 | 1 | RESISTOR | RESISTOR |
| 11-142 | 1 | RESISTOR | RESISTOR |
| 11-143 | 1 | RESISTOR | RESISTOR |
| 11-144 | 1 | RESISTOR | RESISTOR |
| 11-145 | 1 | RESISTOR | RESISTOR |
| 11-146 | 1 | RESISTOR | RESISTOR |
| 11-147 | 1 | RESISTOR | RESISTOR |
| 11-148 | 1 | RESISTOR | RESISTOR |
| 11-149 | 1 | RESISTOR | RESISTOR |
| 11-150 | 1 | RESISTOR | RESISTOR |
| 11-151 | 1 | RESISTOR | RESISTOR |
| 11-152 | 1 | RESISTOR | RESISTOR |
| 11-153 | 1 | RESISTOR | RESISTOR |
| 11-154 | 1 | RESISTOR | RESISTOR |
| 11-155 | 1 | RESISTOR | RESISTOR |
| 11-156 | 1 | RESISTOR | RESISTOR |
| 11-157 | 1 | RESISTOR | RESISTOR |
| 11-158 | 1 | RESISTOR | RESISTOR |
| 11-159 | 1 | RESISTOR | RESISTOR |
| 11-160 | 1 | RESISTOR | RESISTOR |
| 11-161 | 1 | RESISTOR | RESISTOR |
| 11-162 | 1 | RESISTOR | RESISTOR |
| 11-163 | 1 | RESISTOR | RESISTOR |
| 11-164 | 1 | RESISTOR | RESISTOR |
| 11-165 | 1 | RESISTOR | RESISTOR |
| 11-166 | 1 | RESISTOR | RESISTOR |
| 11-167 | 1 | RESISTOR | RESISTOR |
| 11-168 | 1 | RESISTOR | RESISTOR |
| 11-169 | 1 | RESISTOR | RESISTOR |
| 11-170 | 1 | RESISTOR | RESISTOR |
| 11-171 | 1 | RESISTOR | RESISTOR |
| 11-172 | 1 | RESISTOR | RESISTOR |
| 11-173 | 1 | RESISTOR | RESISTOR |
| 11-174 | 1 | RESISTOR | RESISTOR |
| 11-175 | 1 | RESISTOR | RESISTOR |
| 11-176 | 1 | RESISTOR | RESISTOR |
| 11-177 | 1 | RESISTOR | RESISTOR |
| 11-178 | 1 | RESISTOR | RESISTOR |
| 11-179 | 1 | RESISTOR | RESISTOR |
| 11-180 | 1 | RESISTOR | RESISTOR |
| 11-181 | 1 | RESISTOR | RESISTOR |
| 11-182 | 1 | RESISTOR | RESISTOR |
| 11-183 | 1 | RESISTOR | RESISTOR |
| 11-184 | 1 | RESISTOR | RESISTOR |
| 11-185 | 1 | RESISTOR | RESISTOR |
| 11-186 | 1 | RESISTOR | RESISTOR |
| 11-187 | 1 | RESISTOR | RESISTOR |
| 11-188 | 1 | RESISTOR | RESISTOR |
| 11-189 | 1 | RESISTOR | RESISTOR |
| 11-190 | 1 | RESISTOR | RESISTOR |
| 11-191 | 1 | RESISTOR | RESISTOR |
| 11-192 | 1 | RESISTOR | RESISTOR |
| 11-193 | 1 | RESISTOR | RESISTOR |
| 11-194 | 1 | RESISTOR | RESISTOR |
| 11-195 | 1 | RESISTOR | RESISTOR |
| 11-196 | 1 | RESISTOR | RESISTOR |
| 11-197 | 1 | RESISTOR | RESISTOR |
| 11-198 | 1 | RESISTOR | RESISTOR |
| 11-199 | 1 | RESISTOR | RESISTOR |
| 11-200 | 1 | RESISTOR | RESISTOR |

SCHEMATIC REFERENCE L1141-10

MAKE PER E 11
 ENCAPSULATE WITH EPOXY CONTS

TEST PER E 11-21

FOR PARTS AND REPAIR INFORMATION CONTACT:
 LINCOLN ELECTRIC COMPANY

| NO. | DESCRIPTION | QTY. | REVISION |
|-----|-------------|------|----------|
| 1 | ... | ... | ... |
| 2 | ... | ... | ... |
| 3 | ... | ... | ... |
| 4 | ... | ... | ... |
| 5 | ... | ... | ... |
| 6 | ... | ... | ... |
| 7 | ... | ... | ... |
| 8 | ... | ... | ... |
| 9 | ... | ... | ... |
| 10 | ... | ... | ... |

NOTE: Lincoln Electric assumes no responsibility for liabilities resulting from board level troubleshooting. PC Board repairs will invalidate your factory warranty. Individual Printed Circuit Board Components are not available from Lincoln Electric. This information is provided for reference only. Lincoln Electric discourages board level troubleshooting and repair since it may compromise the quality of the design and may result in danger to the Machine Operator or Technician. Improper PC board repairs could result in damage to the machine.

SCHEMATIC - DISPLAY PRINTED CIRCUIT BOARD

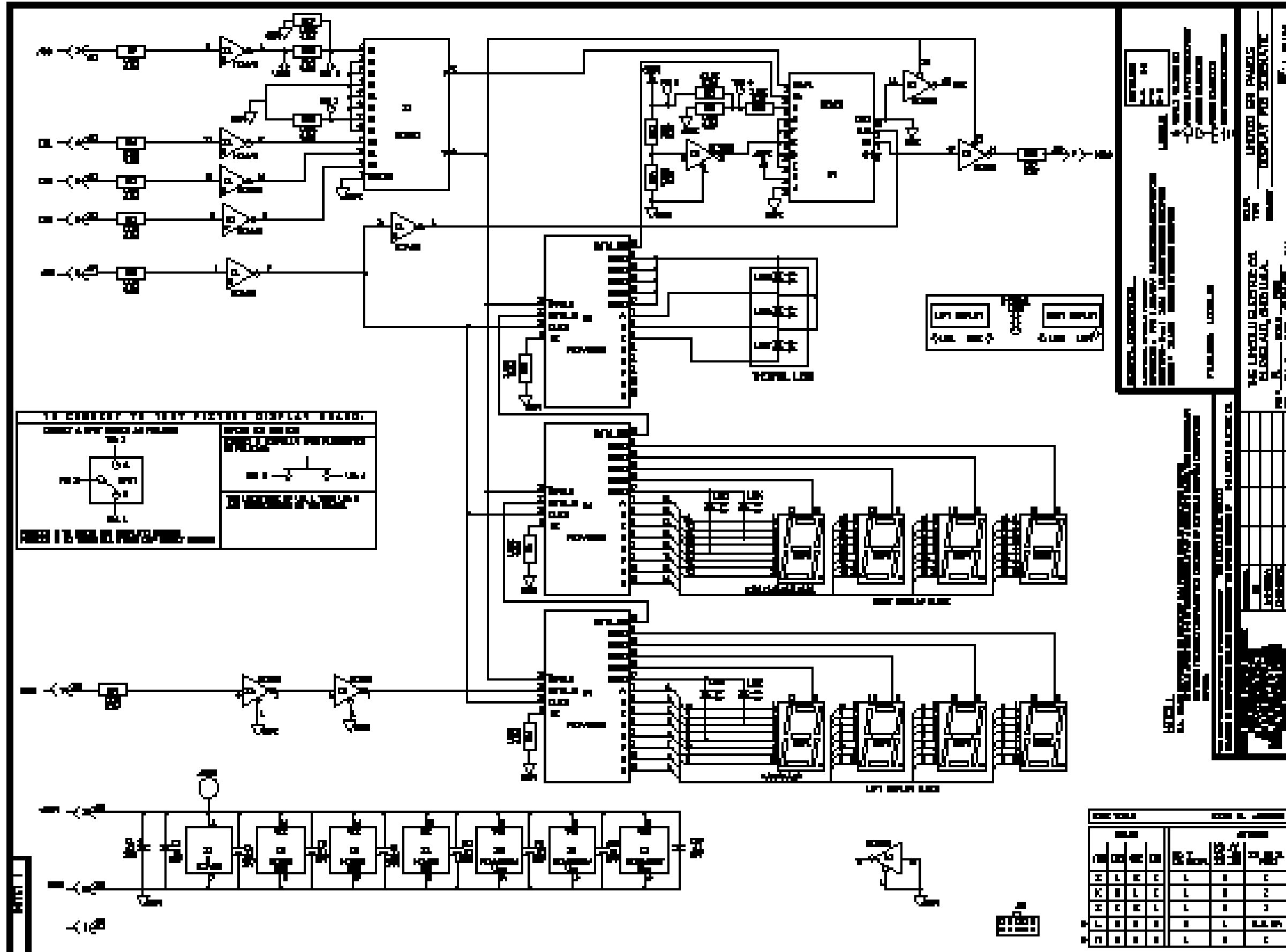

NOTE: This diagram is for reference only. It may not be accurate for all machines covered by this manual.

PC BOARD ASSEMBLY-DISPLAY

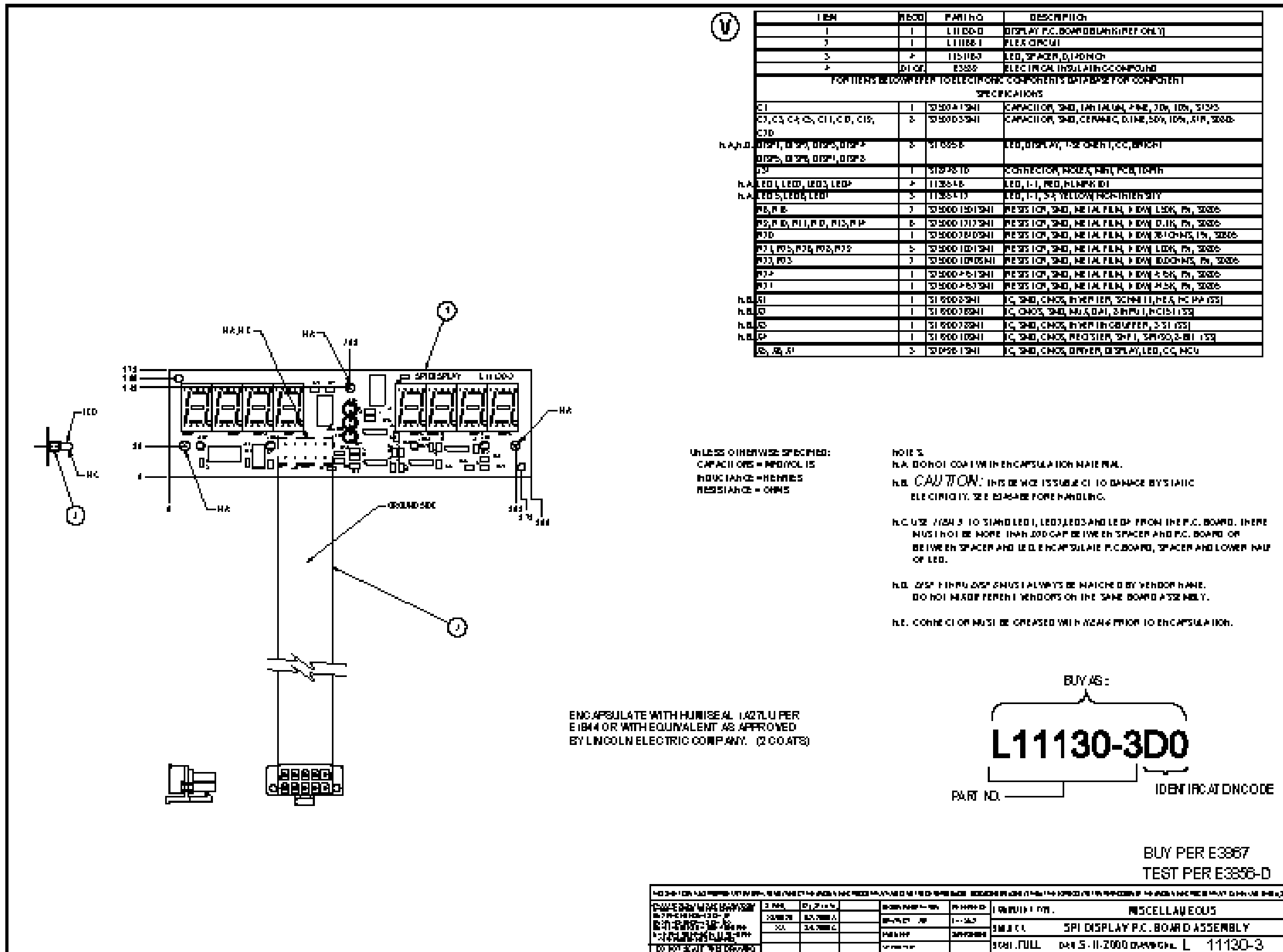

NOTE: Lincoln Electric assumes no responsibility for liabilities resulting from board level troubleshooting. PC Board repairs will invalidate your factory warranty. Individual Printed Circuit Board Components are not available from Lincoln Electric. This information is provided for reference only. Lincoln Electric discourages board level troubleshooting and repair since it may compromise the quality of the design and may result in danger to the Machine Operator or Technician. Improper PC board repairs could result in damage to the machine.

SCHEMATIC - LED SELECT PRINTED CIRCUIT BOARD

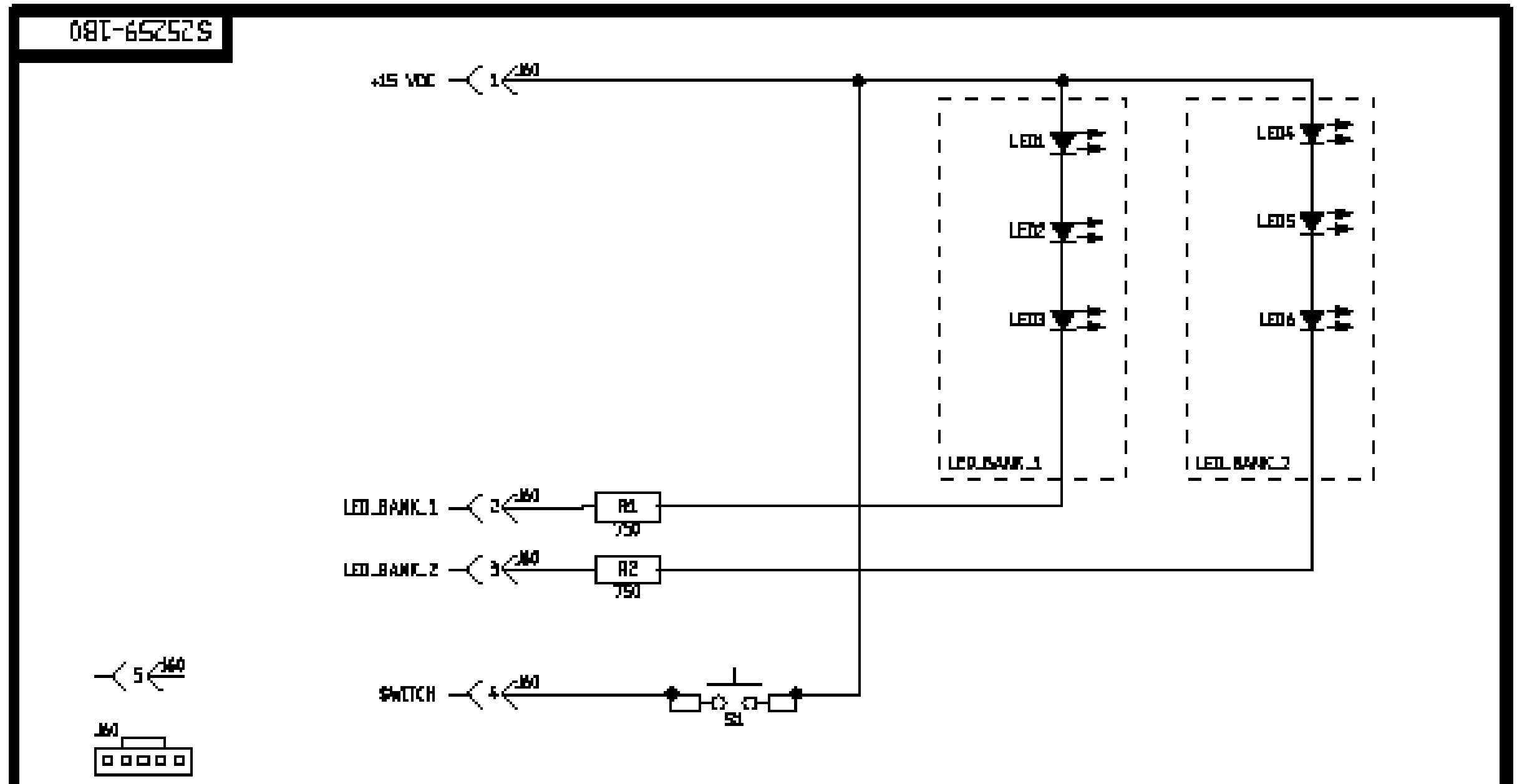

THIS SHEET CONTAINS PROPRIETARY INFORMATION OWNED BY THE LINCOLN ELECTRIC CO. AND IS NOT TO BE REPRODUCED, COPIED OR USED WITHOUT THE EXPRESS PERMISSION OF THE LINCOLN ELECTRIC CO. CLEVELAND, OHIO USA

| | | | |
|---------------------------------------------------------------------------------------------------------------------------------------------------------------------------------------------------------------------------------------------------------------------------|------------------------------------------------------------------------------------------------------------------------------------------------------------------------------------------------------------------------------------------------------|----------------------------------------------------------------------------------------------------------------------------------------------------------------------|------------------------------------------------------------|
| <p>NOTES</p> <p>1. ALL DIMENSIONS UNLESS OTHERWISE SPECIFIED ARE IN MILLIMETERS PER ENGLISH UNITS PLACE DECIMALS TO 0.125 OR 0.25 AS APPLICABLE TO ALL DIMENSIONS UNLESS OTHERWISE SPECIFIED</p> <p>2. ALL DIMENSIONS ARE TO CENTER UNLESS OTHERWISE SPECIFIED</p> | <p>GENERAL INFORMATION</p> <p>ELECTRICAL SYMBOLS PER IEC 60617</p> <p>RESISTORS = R1, R2, ... UNLESS OTHERWISE SPECIFIED</p> <p>INDUCTORS = L1, L2, ... UNLESS OTHERWISE SPECIFIED</p> <p>DIODES = D1, D2, ... UNLESS OTHERWISE SPECIFIED</p> | <p>LEGEND</p> <p>▲ MAINLY MULTIPLEX NET</p> <p>○ POWER SUPPLY BOUND POINT</p> <p>▽ COMMON CONNECTION</p> <p>▭ FRAME CONNECTION</p> <p>⊥ GROUND CONNECTION</p> | <p>LIST NO. USED</p> <p>A-2</p> <p>B-</p> <p>C-</p> |
| | | | <p>FILENAME: S25259_1B</p> |

| | | | | | |
|---------------------------------------------------------------------------------------------------------------------------------------------------------------------------------------------------------------------------------|---------------------|------------------------|---------------------------|-----------------------------------------|------------------------------|
| <p>UNLESS OTHERWISE SPECIFIED TOLERANCES: ALL DIMENSIONS PER ENGLISH UNITS PLACE DECIMALS TO 0.125 OR 0.25 AS APPLICABLE TO ALL DIMENSIONS UNLESS OTHERWISE SPECIFIED</p> <p>DO NOT SCALE THIS DRAWING</p> | <p>Drawn By: XA</p> | <p>DATE: 1-25-2002</p> | <p>DESIGN INFORMATION</p> | <p>EQUIPMENT TYPE: V-350 LED SELECT</p> | |
| | <p>1-25-2002</p> | <p>ENGINEER:</p> | <p>DRAWN BY:</p> | <p>SUBJECT: SCHEMATIC, PC BOARD</p> | |
| | <p>REVISIONS:</p> | <p>REVIEWED BY:</p> | <p>DATE: 01/17/02</p> | <p>SCALE: --- REF: ---</p> | <p>OFFICE NO. S25259-1B0</p> |
| | <p>REVISIONS:</p> | <p>REVIEWED BY:</p> | <p>DATE: 01/17/02</p> | <p>SCALE: --- REF: ---</p> | <p>OFFICE NO. S25259-1B0</p> |

NOTE: This diagram is for reference only. It may not be accurate for all machines covered by this manual.

PC BOARD ASSEMBLY-LED SELECT

P.C. BOARD BLANK INFORMATION:
 MAKE FROM SIBOND (QUINEX) BOARD
 PER PANEL, SEE ELECTRONIC FILE FOR
 ADDITIONAL INFORMATION
 BLANK PART NUMBER
 M19875-1B

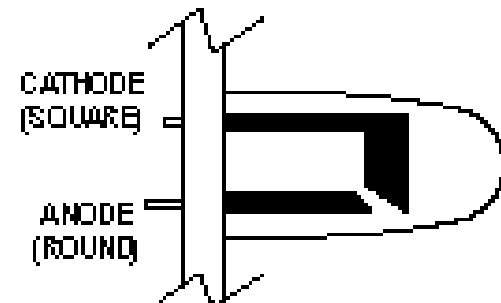

ENLARGED DETAIL
 (LED ORIENTATION)

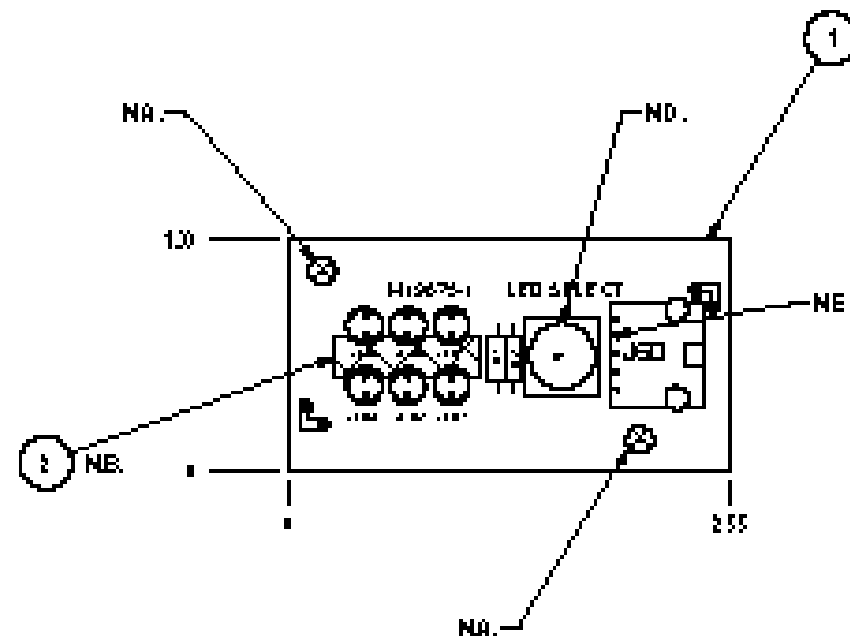

| ITEM | QTY | PART NO | DESCRIPTION |
|--------------------------------------------------------------------------------------|-----|------------|---------------------------------------------|
| 1 | 1 | SEE BLANK | P.C. BOARD BLANK |
| 2 | 1 | C100M25 | RESISTOR, 250 OHMS, 1/4W, 5% |
| FOR ITEMS BELOW REFER TO ELECTRONIC COMPONENTS DATABASE FOR COMPONENT SPECIFICATIONS | | | |
| LED | 1 | 31525-5 | CONNECTOR PCB, W/MALE PINS, 15 PIN |
| LED 1, LED 2, LED 3, LED 4, LED 5, LED 6 | 6 | 11325-13 | LED, 1.125" DIA, RED, HIGH BRIGHTNESS, OVAL |
| R1, R2 | 2 | 31540-1500 | RESISTOR, 1500 OHMS, 1/4W, 5% |
| S1 | 1 | 11325-18 | SWITCH, PUSHBUTTON, 2PST |

RESISTANCE- OHMS

MANUFACTURE AS:

M19875-1B0

PART NO. IDENTIFICATION CODE

ENCAPSULATE WITH E1844 (2 COATS)
 8 RUS HCOAT ACCEPTABLE

NOTES:

- NA. DO NOT COAT WITH ENCAPSULATION MATERIAL
- NB. INSERT ITEM 2 BETWEEN ROWS OF LEDS. ITEM 2 MUST BE FLUSH WITH LED BULB.
- NC. ENCAPSULATE PC BOARD AND LOWER HALF OF LED.
- ND. ENCAPSULATE AROUND BASE OF COMPONENT
- NE. COAT EXTERNAL PINS WITH ENCAPSULATION MATERIAL

SCHEMATIC REFERENCE S25259-1B0

FOR PARTS ORDERS ONLY
 TEST PER E364-ST

| | | | | |
|-------------------------------------------------------------------------------------------------------------------------------------------------------------------------------------------------------------------------------------------------------------------------------------------------|------------------------|---------------------------|----------------------------------------------|-----------------------------------------|
| <p>THIS INFORMATION IS PROVIDED FOR INFORMATION ONLY. IT IS NOT TO BE USED FOR THE IDENTIFICATION OF THE PRODUCT OR FOR THE IDENTIFICATION OF THE PARTS LIST. IT IS NOT TO BE USED FOR THE IDENTIFICATION OF THE PARTS LIST. IT IS NOT TO BE USED FOR THE IDENTIFICATION OF THE PARTS LIST.</p> | <p>DATE: 1-25-2001</p> | <p>REVISION: 1</p> | <p>REFERENCE: 19875-1</p> | <p>EQUIPMENT TYPE: INVERTER WELDERS</p> |
| <p>DATE: 1-25-2001</p> | <p>REVISION: 1</p> | <p>REFERENCE: 19875-1</p> | <p>SUBJECT: LED SELECT PC BOARD ASSEMBLY</p> | <p>SCALE: FULL</p> |
| <p>DATE: 1-25-2001</p> | <p>REVISION: 1</p> | <p>REFERENCE: 19875-1</p> | <p>DATE: 3-21-2001</p> | <p>DRAWING NO.: M 19875-1</p> |

NOTE: Lincoln Electric assumes no responsibility for liabilities resulting from board level troubleshooting. PC Board repairs will invalidate your factory warranty. Individual Printed Circuit Board Components are not available from Lincoln Electric. This information is provided for reference only. Lincoln Electric discourages board level troubleshooting and repair since it may compromise the quality of the design and may result in danger to the Machine Operator or Technician. Improper PC board repairs could result in damage to the machine.

SCHEMATIC - LED POTENTIOMETER PRINTED CIRCUIT BOARD

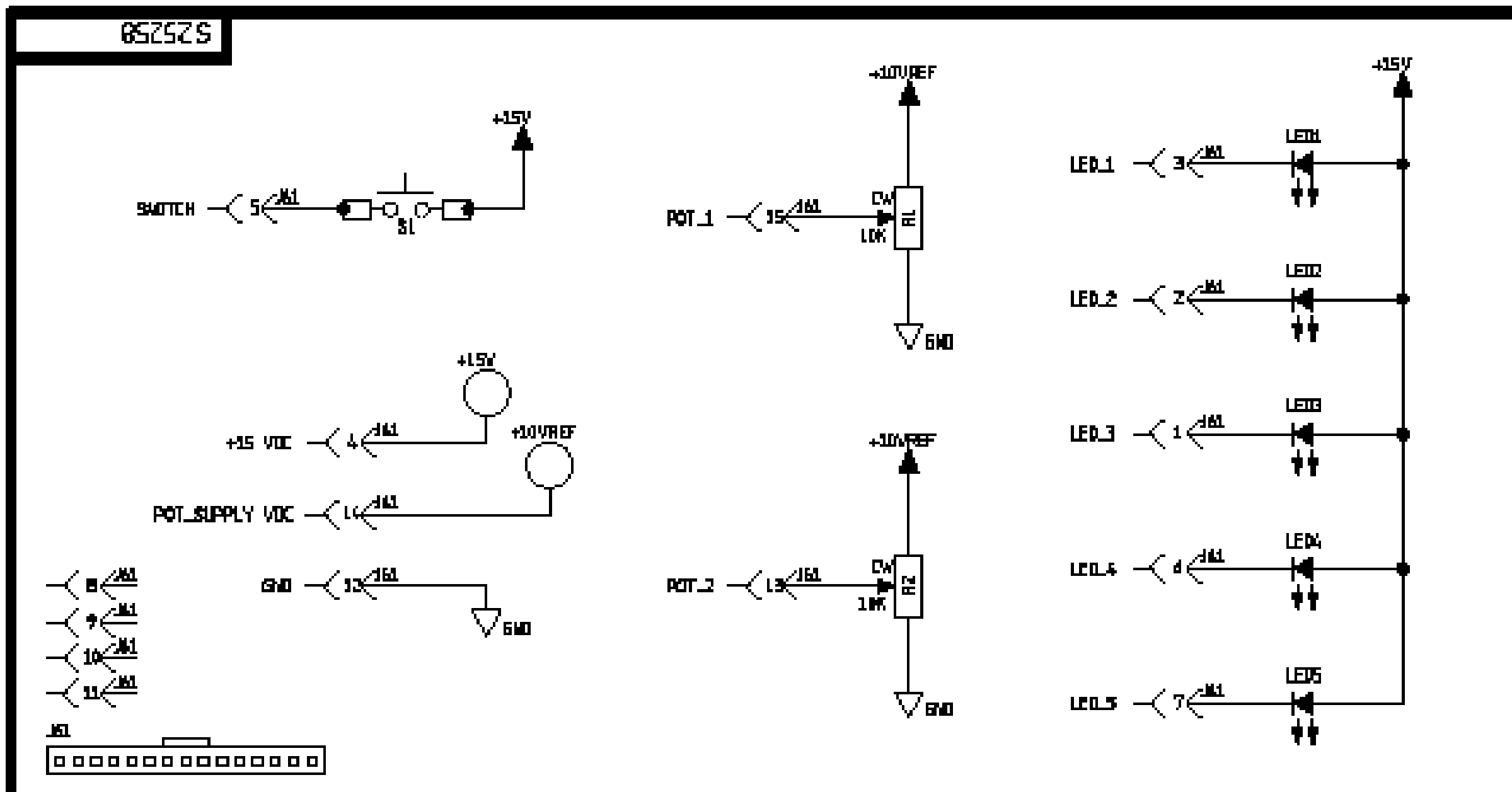

THIS SHEET CONTAINS PROPRIETARY INFORMATION OWNED BY THE LINCOLN ELECTRIC CO. AND IS NOT TO BE REPRODUCED, COPIED, OR USED WITHOUT THE EXPRESS PERMISSION OF THE LINCOLN ELECTRIC CO., CLEVELAND, OHIO, U.S.A.

| | | | |
|----------------------------------------------------------------------------------------------------------------------------------------------------------------------------------------------------------------------------------------------------------------------|---------------------------------------------------------------------------------------------------------------------------------------------------------------------------------------------------------------------------------------------------------------------------|----------------------------------------------------------------------------------------------------------------------------------------------------------------------------------------------------------------------------------------------------------------------------------|--------------------------------------------------------------|
| <p>NOTES:</p> <p>1. MA. SINCE COMPONENTS ON CONDUITY OR A POINTED CONDUIT BOARD MAY CHANGE WITHOUT NOTIFYING THE DISTRIBUTOR/CUSTOMER OF A COMPLETE BOARD, THIS DIAGRAM MAY NOT SHOW THE EXACT COMPONENTS OR CONDUIT IF PARTS ARE FROM A DIFFERENT BOARD.</p> | <p>GENERAL INFORMATION</p> <p>ELECTRICAL SYMBOLS PER IEEE</p> <p>RESISTORS = \square UNLESS OTHERWISE SPECIFIED</p> <p>INDUCTORS = \square UNLESS OTHERWISE SPECIFIED</p> <p>COILS = \square UNLESS OTHERWISE SPECIFIED</p> | <p>LEGEND</p> <p>\oplus MAINLY ELECTRICAL NET</p> <p>\ominus POWER SUPPLY BIASING POINT</p> <p>∇ COMMON CONNECTION</p> <p>--- FRAME CONNECTION</p> <p>--- EARTH GROUND CONNECTION</p> | <p>UNIT NO. USED</p> <p>R -</p> <p>G -</p> <p>D -</p> |
| | | | <p>FILENAME: S25258-1A</p> |

| | | | | |
|---------------------------------------------------------------------------------------------------------------------------------------------------------------------------------------------------------------------------------------------------------------------------------------------------------------------------------------------------------------------------------------------|-------------------------|-------------------------------------------|--------------------------------------------------------------------------------------------|-------------------------------------------------------------------------------------------------------------------|
| <p>UNLESS OTHERWISE SPECIFIED TOLERANCES: DR HOLE SIZE PER ANSI DR ± FORCE DECIMALS DR ± .02 DR ± PLUG DECIMALS DR ± .002 ON ALL PACKAGES & IS OF PLASTIC MATERIAL TO EXCEED 1.5 TO 3.0mm UNLESS OTHERWISE SPECIFIED</p> <p>DO NOT SCALE THIS DRAWING</p> | <p>Doc. Sheet No.</p> | <p>REV. INFO</p> <p>5011992</p> <p>NA</p> | <p>DESIGN INFORMATION</p> <p>DRAWN BY: CFH</p> <p>ENGINEER: CFH</p> <p>REVIEWED BY: --</p> | <p>EQUIPMENT TYPE: V350 LED/POT</p> <p>SUBJECT: LED/POT PCB SCHEMATIC</p> <p>DATE: 03/11/01 SCALE: -- REF: --</p> |
| | <p>FILE NO. S25258</p> | | | |
| | <p>DRWG. NO. S25258</p> | | | |
| | <p>NO.</p> | | | |

NOTE: This diagram is for reference only. It may not be accurate for all machines covered by this manual.

PC BOARD ASSEMBLY-LED POTENTIOMETER

P.C. BOARD BLANK INFORMATION:
 MAKE FROM S 5011 (MACHINE & BOARD)
 PER PANEL, SEE ELECTRONIC FILE FOR
 ADDITIONAL INFORMATION
 BLANK PART NUMBER
 M19874-1A2

| ITEM | QTY | PART NO. | DESCRIPTION |
|----------------------------------------------------------------------------------------|-----|------------|-------------------------------------------|
| 1 | 1 | SEE BLANK | P.C. BOARD BLANK |
| 2 | 1 | 115116-1 | LED SPACER |
| FOR ITEM #S BELOW REFER TO ELECTRONIC COMPONENTS DATABASE FOR COMPONENT SPECIFICATIONS | | | |
| JS1 | 1 | 31525-1 | CONNECTION, PCB, W/MMALE, P1-L, 15-PIN |
| LED1, LED2, LED3, LED4, LED5 | 5 | 11325-1-11 | LED, 1-1/2" PRED, HIGH INTENSITY |
| PI1, PI2 | 2 | 31525-1 | PCB, S1, D, SW, 10K, 10% LINEAR |
| SI | 1 | 11331-11 | SWITCH, PUSH BUTTON, SPST, GREEN, W/BLACK |

RESISTANCE = 0 OHMS

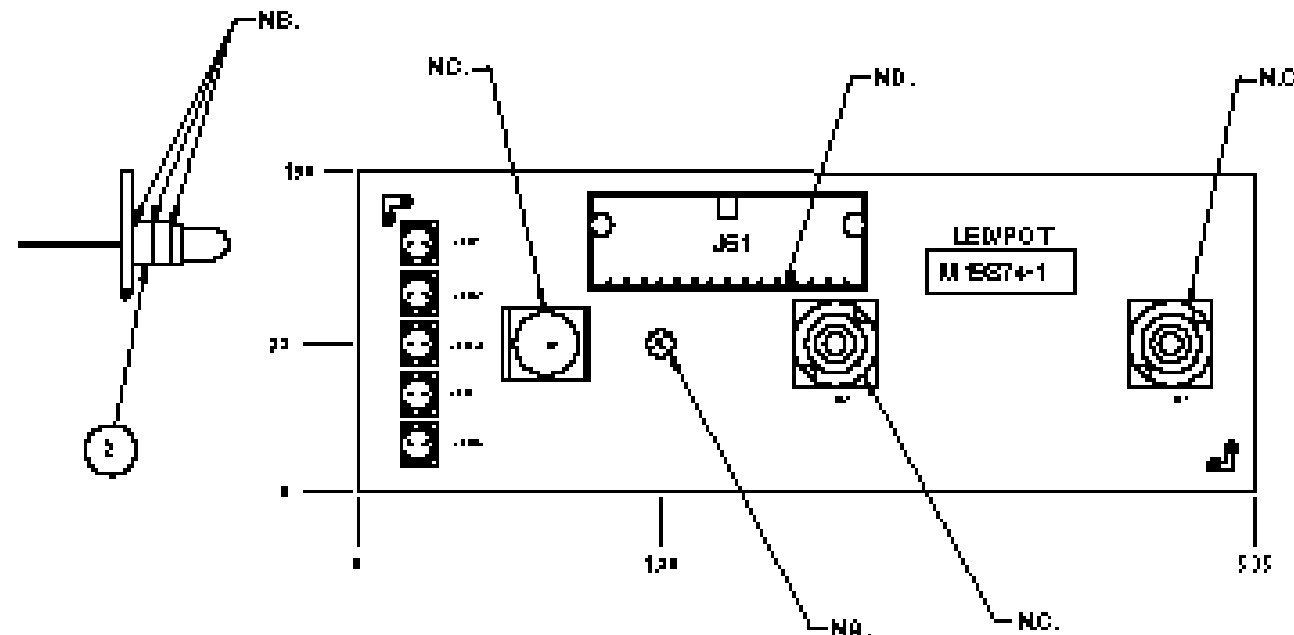

MANUFACTURE AS:
 M19874-1A2
 PART NO. IDENTIFICATION CODE

ENCAPSULATE WITH E1644 (2 COATS)
 BRUSH COAT ACCEPTABLE

NOTES:

- N.A. DO NOT COAT WITH ENCAPSULATION MATERIAL
- N.B. THERE MUST NOT BE MORE THAN A .010 GAP BETWEEN SPACER & LED, OR BETWEEN SPACER & P.C. BOARD. ENCAPSULATE P.C. BOARD SPACERS & LOWER HALF OF LED LEADS MUST BE PERPENDICULAR WITH P.C. BOARD.
- N.C. ENCAPSULATE AROUND BASE OF COMPONENT
- N.D. COAT EXTERNAL PINS WITH ENCAPSULATION MATERIAL

SCHEMATIC REFERENCE S25258-1A1

FOR PARTS ORDERS ONLY
 TEST PER E364-106

| REVISION | DATE | BY | DESCRIPTION | REVISION | DATE | BY | DESCRIPTION |
|----------|-----------|----|-------------|----------|------|----|-------------|
| 1 | 1-25-2001 | | | 1 | | | |

| | |
|-----------------|-----------------------------|
| EQUIPMENT TYPE: | INVERTER WELDERS |
| SUBJECT: | LED POT P.C. BOARD ASSEMBLY |
| SCALE: | FULL |
| DATE: | 3-9-2001 |
| DRAWING NO.: | M 19874-1 |

NOTE: Lincoln Electric assumes no responsibility for liabilities resulting from board level troubleshooting. PC Board repairs will invalidate your factory warranty. Individual Printed Circuit Board Components are not available from Lincoln Electric. This information is provided for reference only. Lincoln Electric discourages board level troubleshooting and repair since it may compromise the quality of the design and may result in danger to the Machine Operator or Technician. Improper PC board repairs could result in damage to the machine.

SCHEMATIC-SPI REMOTE PRINTED CIRCUIT BOARD

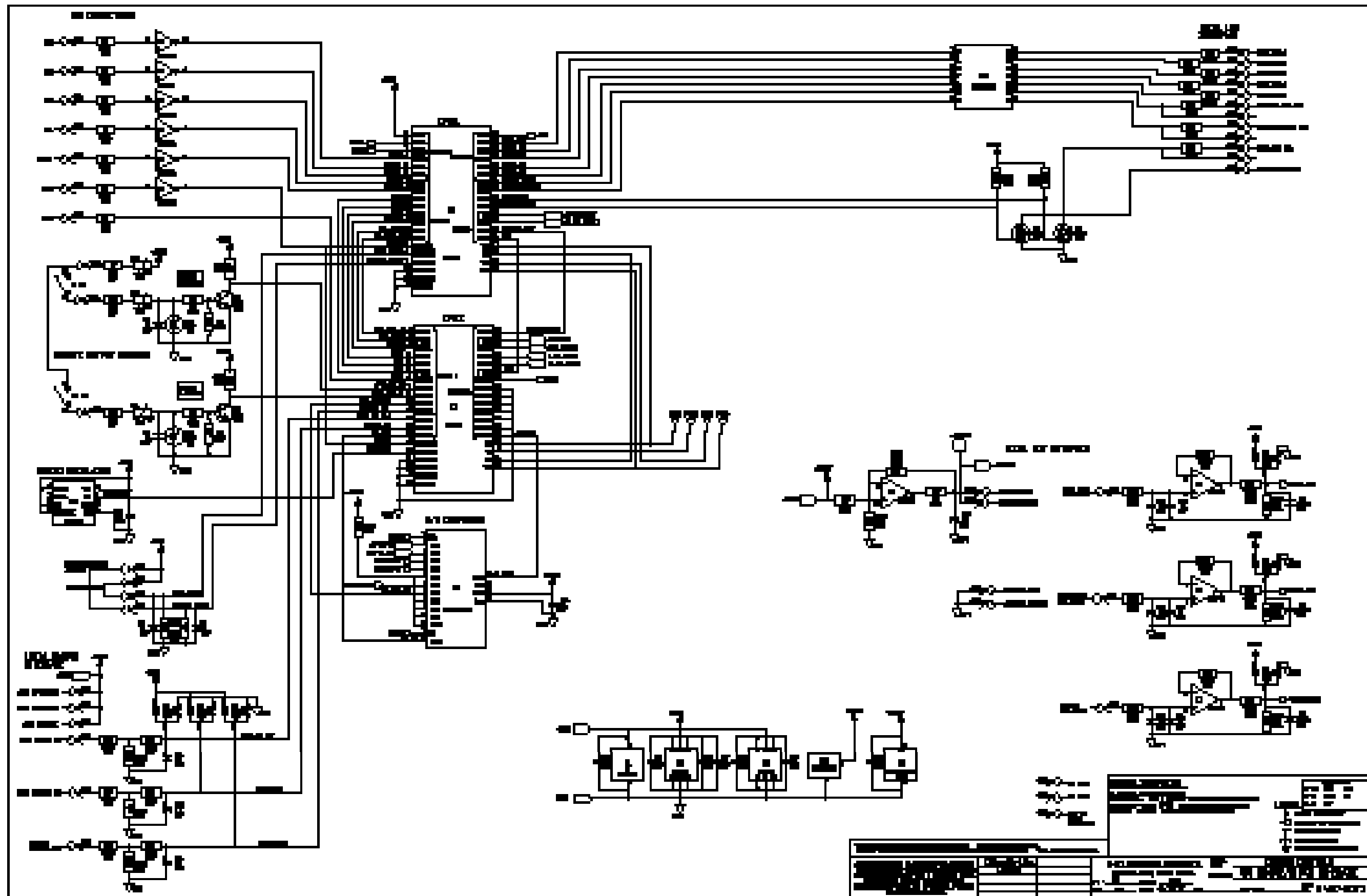

NOTE: This diagram is for reference only. It may not be accurate for all machines covered by this manual.

PC BOARD ASSEMBLY-SPI REMOTE

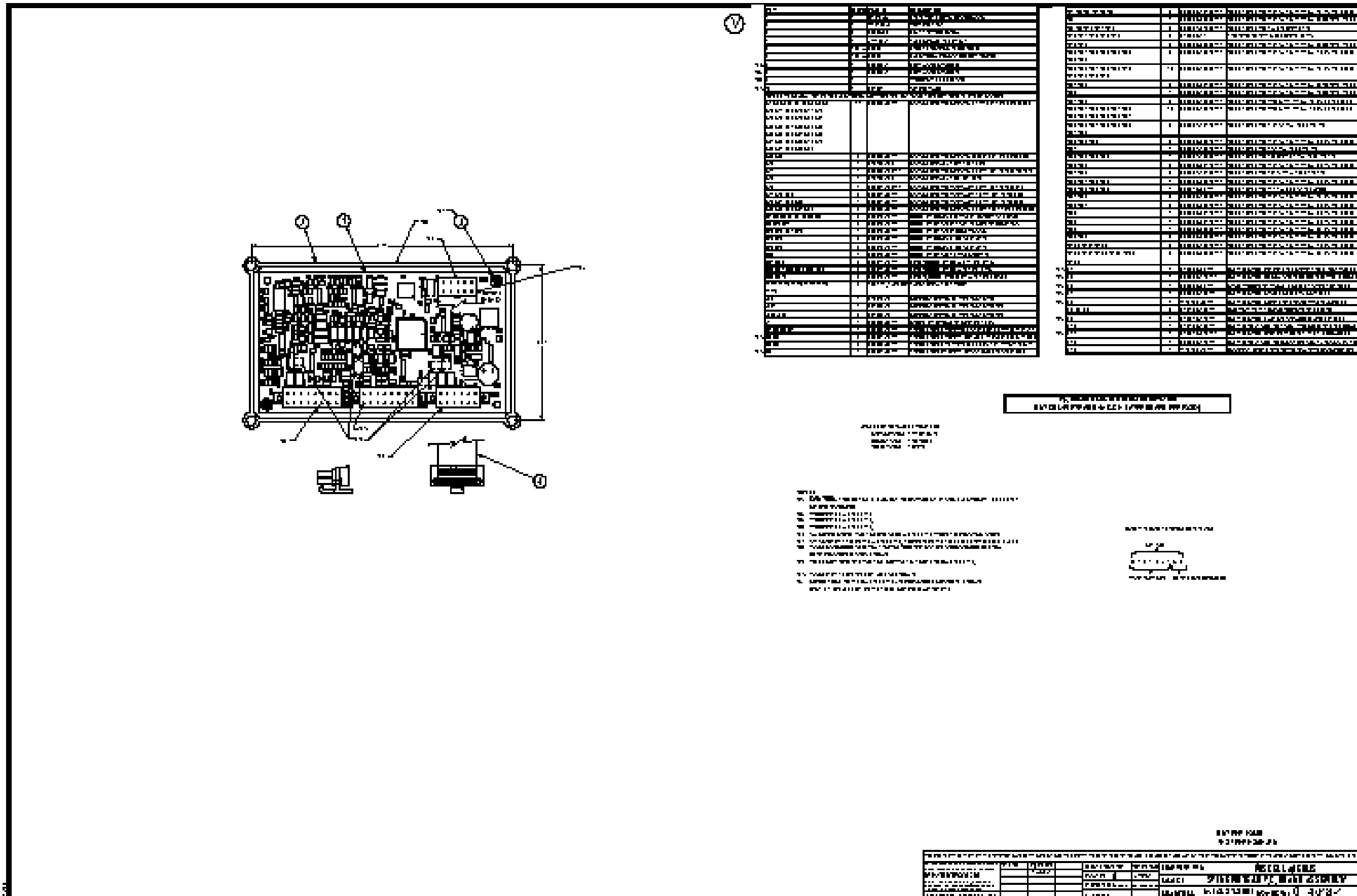

SCHEMATIC-SNUBBER PRINTED CIRCUIT BOARD

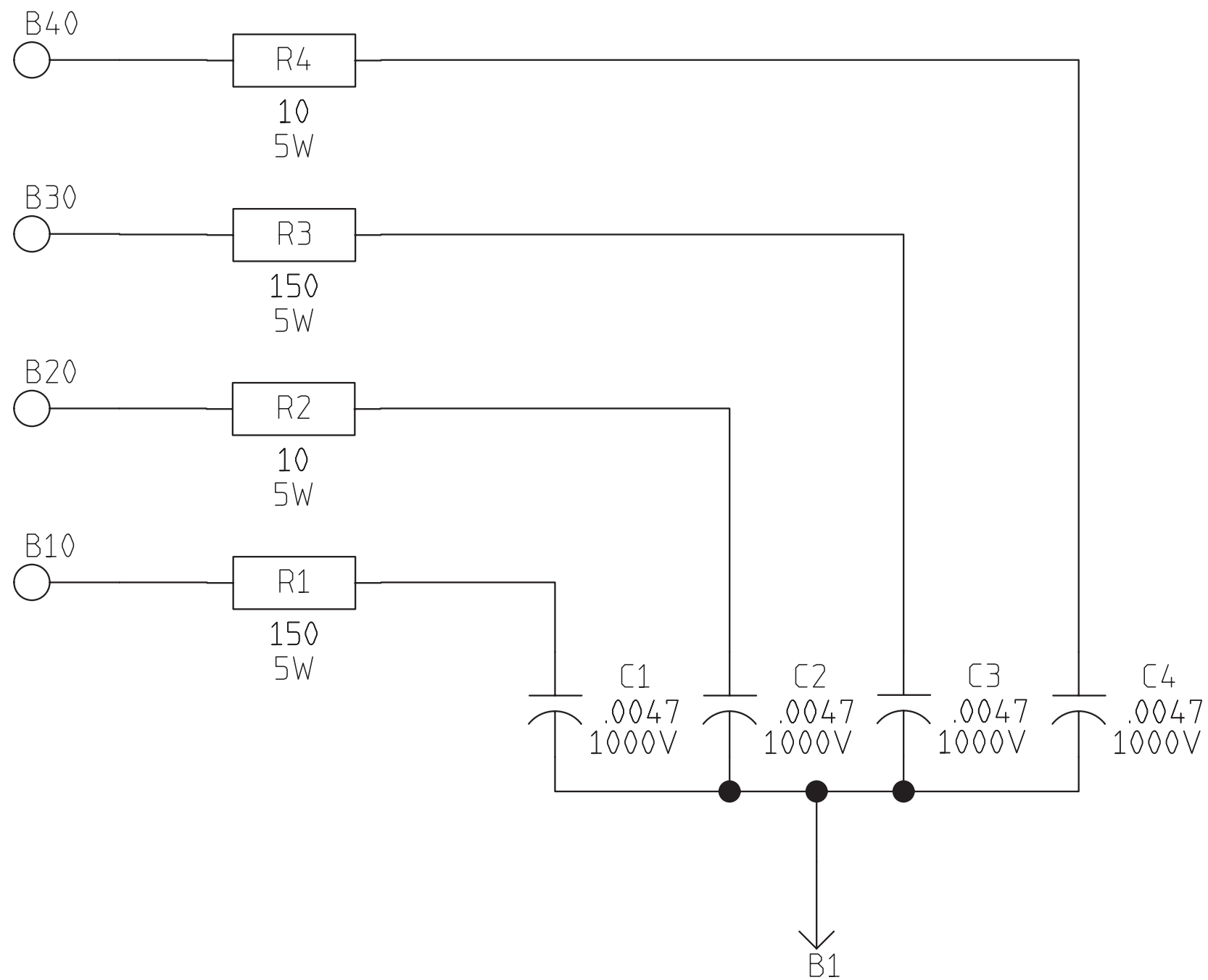

6-2-2000
S24761

NOTE: This diagram is for reference only. It may not be accurate for all machines covered by this manual.

PC BOARD ASSEMBLY-SNUBBER

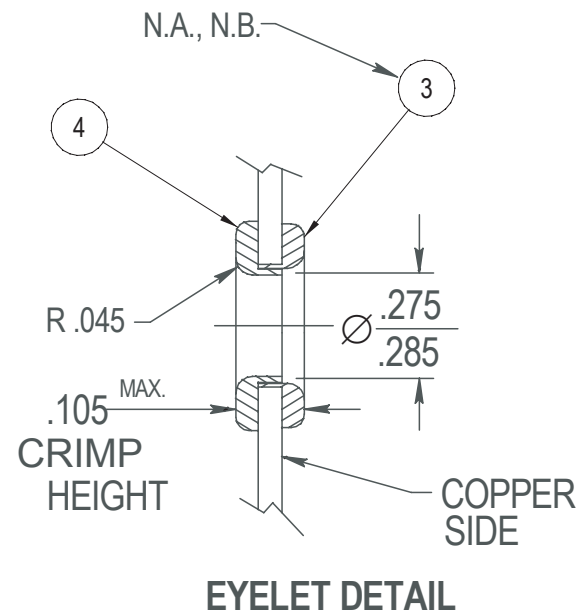
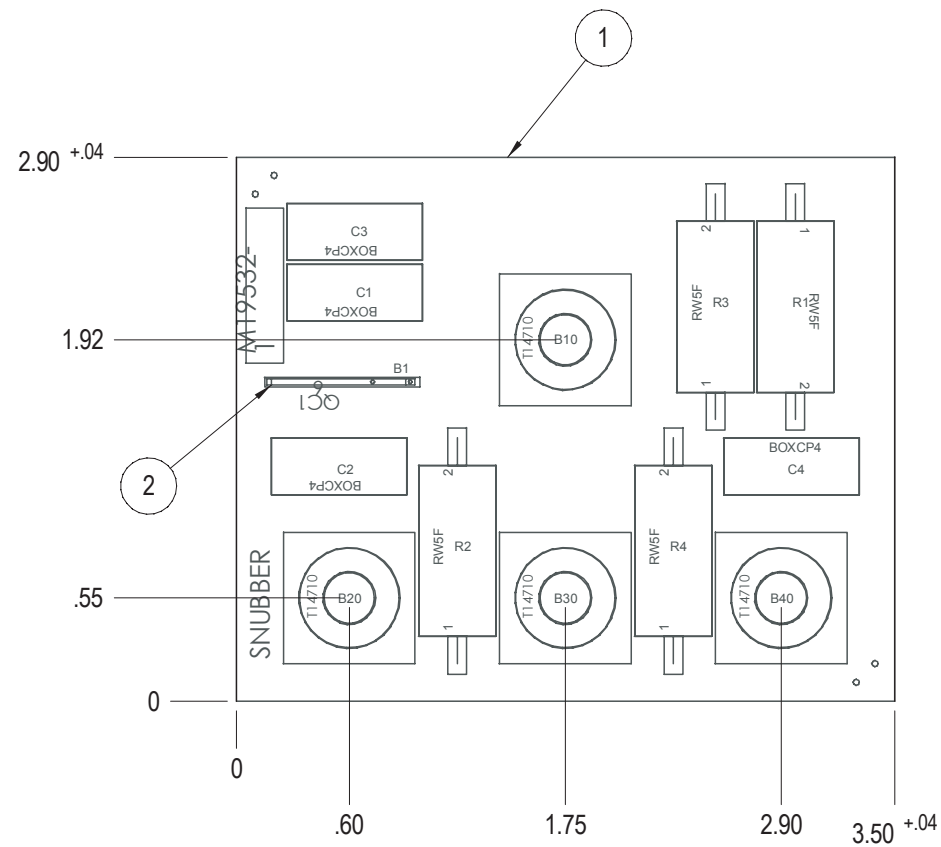

MAKE PER E1911
ENCAPSULATE WITH E1844, 2 COATS
TEST PER E3817-SN

| ITEM | REQ'D | PART NO. | DESCRIPTION |
|-------------|-------|-----------|--------------------------------|
| C1,C2,C3,C4 | 4 | S20500-4 | CAPACITOR,PPMF,.0047,1000V,BOX |
| R1,R3 | 2 | T14648-20 | RESISTOR,WW,5W,150,5%,SQ |
| R2,R4 | 2 | T14648-25 | RESISTOR,WW,5W,10,5%,SQ |

| ITEM | PART NO. | DESCRIPTION | QTY |
|------|-----------|------------------|-----|
| 1 | M19532-A | P.C. BOARD BLANK | 1 |
| 2 | T13157-16 | TAB TERMINAL | 1 |
| 3 | T9147-11 | EYELET-FEMALE | 4 |
| 4 | T9147-15 | EYELET-MALE | 4 |

NOTES:
N.A. FEMALE EYELET TO BE AGAINST THE COPPER SIDE AS SHOWN
EYELET MUST NOT SPIN AFTER CLINCHING.
N.B. SOLDER EYELET SO THAT SOLDER COVERS ENTIRE EYELET
AND ALL AROUND EYELET ON COPPER SIDE ONLY.
NO ICICLES OR SOLDER BLOBS PERMITTED.

MANUFACTURED AS:

M19532-1A0

IDENTIFICATION CODE

THIS SHEET CONTAINS PROPRIETARY INFORMATION OWNED BY THE LINCOLN ELECTRIC COMPANY AND IS NOT TO BE REPRODUCED, DISCLOSED OR USED WITHOUT THE EXPRESS WRITTEN PERMISSION OF THE LINCOLN ELECTRIC COMPANY, CLEVELAND, OHIO U.S.A.

| | | | | | |
|--------------------------------------------------------------------------------------------------------------------------------------------------------------------------------------------------------------------------------------------------------------------------------|----------------|-----------|--------------------|--------------|-------------------------------------------------------|
| UNLESS OTHERWISE SPECIFIED TOLERANCE MANUFACTURING TOLERANCE PER E2056 ON 2 PLACE DECIMALS IS ± .02 ON 3 PLACE DECIMALS IS ± .002 ON ALL ANGLES IS ± .5 OF A DEGREE MATERIAL TOLERANCE ("I") TO AGREE WITH PUBLISHED STANDARDS. DO NOT SCALE THIS DRAWING | Chg. Sheet No. | "X" INFO. | DESIGN INFORMATION | REFERENCE: | EQUIPMENT TYPE: |
| | 6-2-2000 | XM5626 | DRAWN BY: F.V. | | INVERTER WELDERS |
| | | XC-UF | ENGINEER: | SUPERSEDING: | SUBJECT: |
| | | | APPROVED: | | SNUBBER P.C. BOARD ASSEMBLY |
| | | | | | SCALE:NONE DATE:10-6-99 DRAWING No.: M 19532-1 |

EN-166

SOLID EDGE

NOTE: Lincoln Electric assumes no responsibility for liabilities resulting from board level troubleshooting. PC Board repairs will invalidate your factory warranty. **Individual Printed Circuit Board Components are not available from Lincoln Electric.** This information is provided for reference only. Lincoln Electric discourages board level troubleshooting and repair since it may compromise the quality of the design and may result in danger to the Machine Operator or Technician. Improper PC board repairs could result in damage to the machine.

SVM ERROR REPORTING FORM

We need to know if there are errors in our manuals. We also value any suggestions as to additional tests or procedures that would make this SVM a better tool for you.

If you discover new or different "Problems or Symptoms" that are not covered in the three column troubleshooting chart, please share this information with us. Please include the machine's code number and how the problem was resolved.

Thank You,
Technical Services Group
Lincoln Electric Co.
22801 ST. Clair Ave.
Cleveland, Ohio 44117-1199

FAX 216-481-2309

SVM Number _____

Page Number if necessary _____

Your Company _____

Your Name _____

Please give detailed description below:
